

4060 Service and Parts Manual



1750040-001A

MINOLTA
QMS

The essentials of imaging

www.minolta-qms.com

CHAPTER 1 GENERAL INFORMATION

Chapter 1 contents include:

Section

1-1	Introduction.....	1-3
1-2	Printer Specifications	1-4
	1-2.1 Printer General Specifications	1-4
	1-2.2 Printer Print Speed Specifications	1-5
	1-2.3 Printer Physical Specifications	1-6
	1-2.4 Printer Electrical Specifications.....	1-6
	1-2.5 Environmental Specifications For All Equipment.....	1-8
1-3	Summary of Printer Optional Features and Feature Specifications.....	1-9
1-4	Large-Capacity Hopper (LCH).....	1-9
	1-4.1 LCH Overview.....	1-9
	1-4.2 LCH Paper Handling Specifications.....	1-10
	1-4.3 LCH Physical Specifications	1-11
	1-4.4 LCH Electrical Specifications.....	1-12
	1-4.5 LCH Environmental Specifications	1-12
1-5	Large-Capacity Stacker (LCS).....	1-12
	1-5.1 LCS Overview	1-12
	1-5.2 LCS Paper Handling Specifications.....	1-13
	1-5.3 LCS Physical Specifications.....	1-14
	1-5.4 LCS Electrical Specifications	1-14
	1-5.5 LCS Environmental Specifications.....	1-14
1-6	Printer Custom Paper Tray.....	1-15
1-7	Printer Consumable Specifications	1-15
1-8	Best Printing Area Specifications	1-17
1-9	System Configuration Component Locations and Descriptions.....	1-20
	1-9.1 Front and Right Side of the Printer	1-20
	1-9.2 Behind the Front Door	1-22
	1-9.3 Behind the Upper Right Cover	1-24
	1-9.4 Behind the Lower Right Cover	1-25
	1-9.5 Rear and Left Side of the Printer	1-26
	1-9.6 Rear-Inside of the Printer.....	1-28
	1-9.7 Large-Capacity Hopper (LCH) Accessory	1-30
	1-9.8 Large-Capacity Stacker (LCS) Accessory	1-31
1-10	Printer Component Block Diagram	1-32
1-11	Safety and Regulatory Information.....	1-36
1-12	Servicing Approach	1-36

SERVICE MANUAL

NOTE

This page intentionally left blank.

1-1. Introduction

This chapter provides specifications, safety compliance, options, available supplies, printing paper and design, system configuration, related manuals, and servicing approach for the 4060 cut sheet printer and supporting optional Large-Capacity Hopper (LCH) and Large-Capacity Stacker (LCS) paper handlers.

The 4060 non-impact printer combines semiconductor laser optical technology and two-component dry development process technology to print on cut-sheet plain paper. Figure 1-1 illustrates an installed printer and the external large capacity paper handling options.

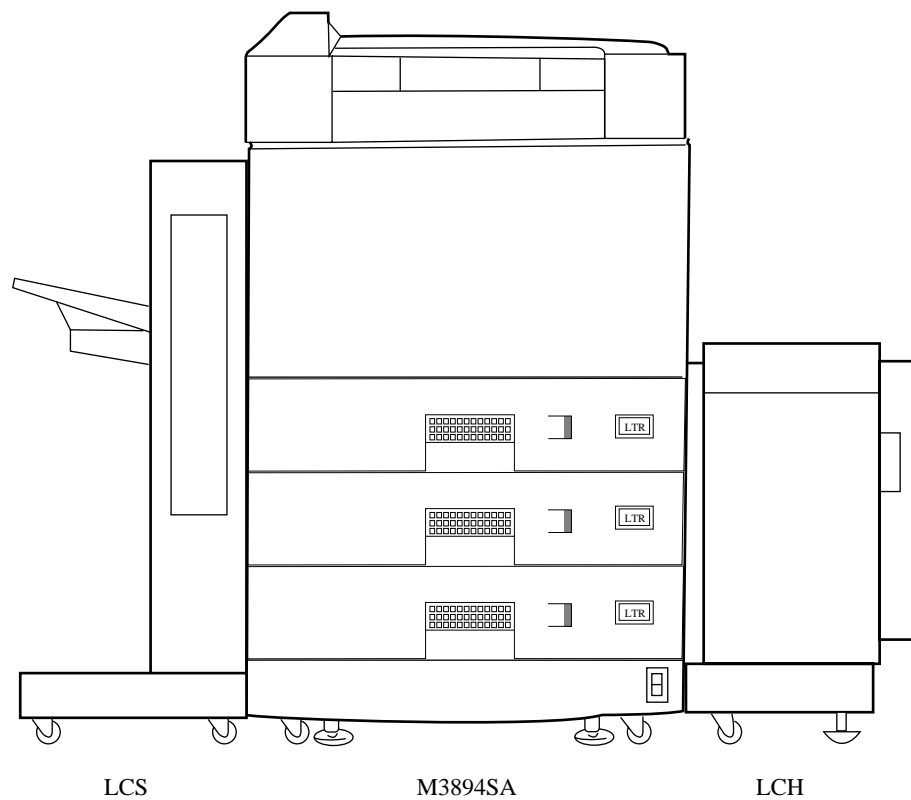

Figure 1-1. 4060 Printer With Optional LCH and LCS Paper Handlers

SERVICE MANUAL

1-2. Printer Specifications

This section provides general, print speed, physical, electrical, environmental specifications as well as safety standards applicable to all equipment and an illustration of the printer laser equipment warning label.

1-2.1. Printer General Specifications

Table 1-1 lists general specifications for the 4060 printer.

Table 1-1. 4060 Printer General Specifications

Item		Specifications
Printing technology		Laser diode, Electro-photography
Printing speed		40 ppm (Letter and A4 landscape)
Paper	Size	Letter, Legal, Ledger, Executive, A3, A4, A5, B4 (JIS), B5 (JIS)
	Type	Plain Paper, Label paper, Recycle paper, Transparency paper, Bond paper, Pre-punched paper
Resolution		600 × 600 dpi
Paper capacity		• 3 trays × 500 sheets (64 g/m ²) standard
		• 1 tray × 500 sheets (64 g/m ²) optional custom tray
		• 3,000 sheets (A4, Letter size only) optional Large-Capacity Hopper (LCH)
Stacker capacity		• 500 sheets (64 g/m ²) face down tray
		• 2,000 sheets optional Large-Capacity Stacker (LCS)

1-2.2. Printer Print Speed Specifications

Table 1-2 lists the specifications for the 4060 printer print speeds.

Table 1-2. 4060 Printer Print Speed Specifications

Paper Size (direction)	Simplex *2	Duplex *2
Letter (landscape)	40	40
Legal (portrait)	25	25
Ledger (portrait)	21	15
Executive (portrait)	40	40
A3 (portrait)	21	15
A4 (landscape)	40	40
A5 (portrait)	40	40
B4 (JIS) (portrait)	24	24
B5 (JIS) (portrait)	30	30
B4 (ISO) (portrait) *1	21	15

B5 (ISO) (portrait) *1	40	40
Custom (paper width = 120mm to 297mm, paper length = 182mm to 215.9mm) *1	24	24
Custom (paper width = 120mm to 297mm, paper length = 215.9mm to 431.8mm) *1	34	34
Notes:		
*1: Can be fed from optional custom paper tray only.		
*2: Unit of measure: Images Per Minute (IPM). All the speeds have $\pm 5\%$ tolerance.		

1-2.3. Printer Physical Specifications

Table 1-3 lists the printer physical specifications.

Figure 1-2 illustrates the physical specifications and Figure 1-3 illustrates the required printer service area dimensions.

Table 1-3. 4060 Printer Physical Specifications

Item	Specification			
Dimensions	Width	Depth	Height	
	585 mm (23.0 in)	640 mm (25.2 in)	1,030 mm (40.6 in)	
Weight	Approximately 135 kg			
Service area	Front	Back	Left	Right
	650 mm (25.6 in)	850 mm (33.5 in)	850 mm (33.5 in)	850 mm (33.5 in)

1-2.4. Printer Electrical Specifications

Table 1-4 lists the printer electrical specifications.

Table 1-4. 4060 Printer Electrical Specifications

Item	Specifications	
Input power	Voltage	120 to 127 VAC $\pm 10\%$, 12A 200 to 240 VAC $\pm 10\%$ 7A
	Phase	Single-phase
	Frequency	50/60Hz $\pm 5\%$
Power consumption	1,300 VA or less than during operating	
Heat capacity	894 kcal per hour	

SERVICE MANUAL

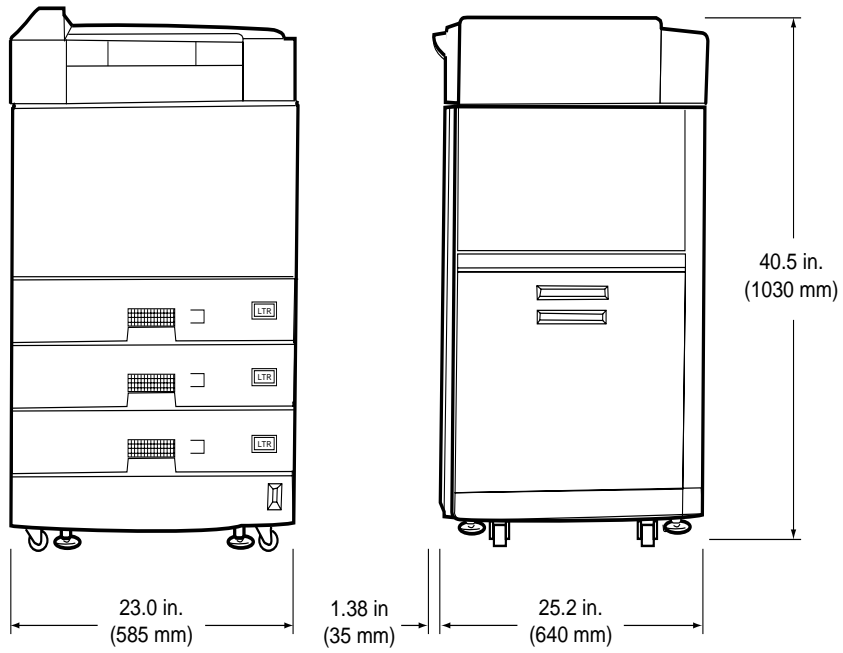

Figure 1-2. 4060 Printer Physical Dimensions

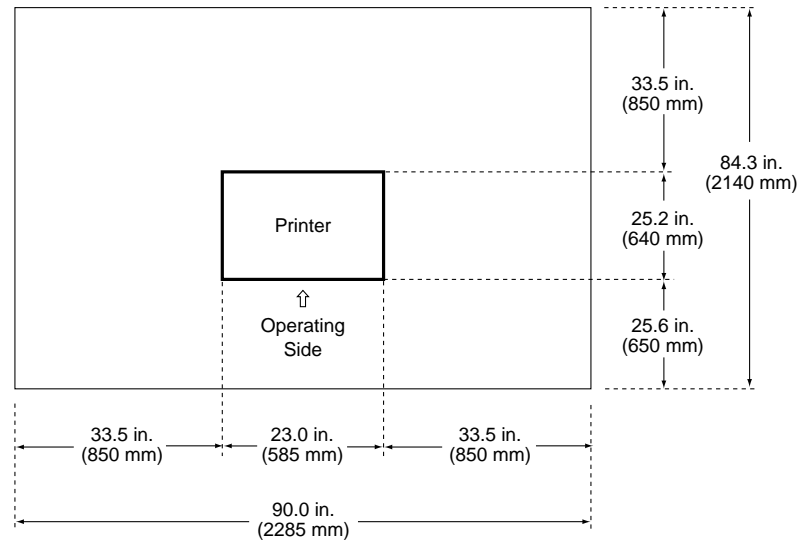

Figure 1-3. 4060 Printer Required Service Area Dimensions

1-2.5. Environmental Specifications For All Equipment

Table 1-5 lists environmental specifications applicable to the printer, LCH, and LCS units.

Table 1-5. 4060 Printer, LCH Option, and LCS Option Environmental Specifications

Item		Specification	
		Operating	Non-operating
Ambient Condition	Device condition	Operating	Non-operating
	Temperature	10 to 35 °C	0 to 35 °C
	Humidity	20 to 80% RH (no condensation)	20 to 80% RH (no condensation)
	Temperature and humidity gradients	15 °C per hour or less and 30% RH per day or less (no condensation)	
Acoustic noise		55 dBA or less (printer only)	
Dust		0.15 mg./m ³ (stearic acid)	
Ozone emission		0.1 PPM or less	

1-3. Summary of Printer Optional Features and Feature Specifications

Table 1-6 lists the options available with the 4060 printer along with their associated specifications.

SERVICE MANUAL

Table 1-6. 4060 Printer Available Options and Specifications Summary

Item	Specification	Model Number
Large-Capacity Hopper (LCH)	3,000 sheets (75 g/m ²)	4060 (Letter) 4060 (A4)
Large-Capacity Stacker (LCS)	2,000 sheets (75 g/m ²)	4060 (120 VAC) 4060 (240 VAC)
Custom paper tray	500 sheets (75 g/m ²)	

1-4. Large-Capacity Hopper (LCH)

1-4.1. LCH Overview

Models **4060** and **4060** are the user-installable optional Large-Capacity Hoppers (LCH) units for the 4060 printer, connecting to the right side of the printer. The **4060** can feed Letter size paper only, and the **4060** can feed A4 size paper. Both LCHs can be installed up to 3000 sheets of paper (75g/m²).

Figure 1-4 illustrates the Large-Capacity Hopper unit.

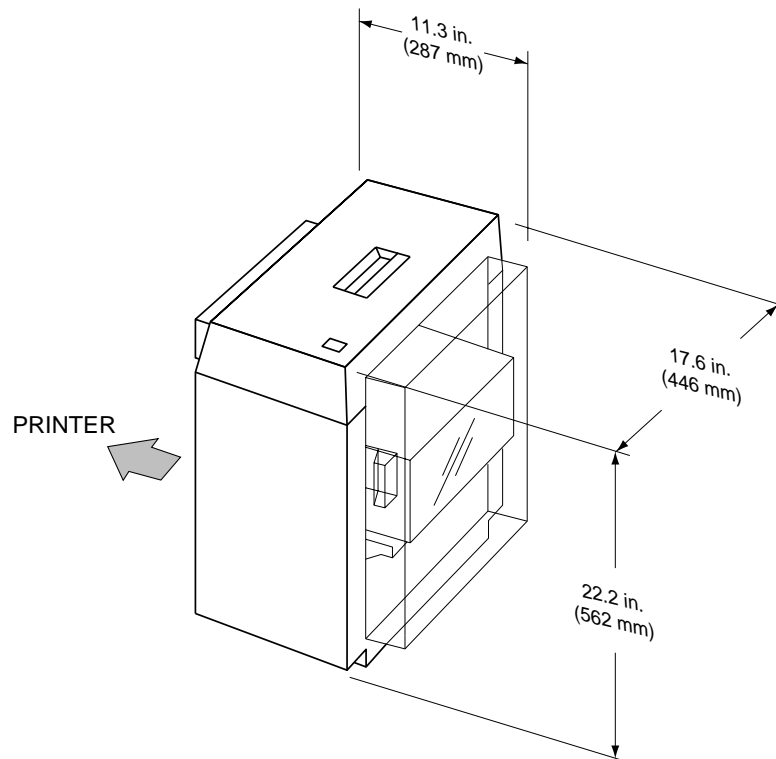

Figure 1-4. Large-Capacity Hopper Physical Dimensions

1-4.2. LCH Paper Handling Specifications

Table 1-7 lists the LCH paper related specifications.

Table 1-7. LCH Paper Handling Specifications

Item	Specifications
------	----------------

SERVICE MANUAL

Processing speed	40 ppm (4060: Letter landscape and 4060: A4 landscape)	
Paper	Size	4060: Letter and 4060: A4
	Type	Plain paper, Label paper, Transparency, Bond paper, Pre-punched paper 64 to 90g/m ²
Paper capacity	3,000 sheets (75g/ m ²)	

1-4.3. LCH Physical Specifications

Table 1-8 lists the LCH physical dimensions, unit weight, and required service area dimensions and Figure 1-4 illustrates these dimensions. Figure 1-5 illustrates the LCH service area requirements.

Table 1-8. LCH Physical Specifications

Item	Specification		
Dimensions	Width	Depth	Height
	287 mm (11.3 in)	446 mm (17.6 in)	562 mm (22.2 in)
Weight	About 17 kg (38 lbs)		
Service area	Front	Back	Right
	650 mm (25.6 in)	850 mm (33.5 in)	850 mm (33.5 in)

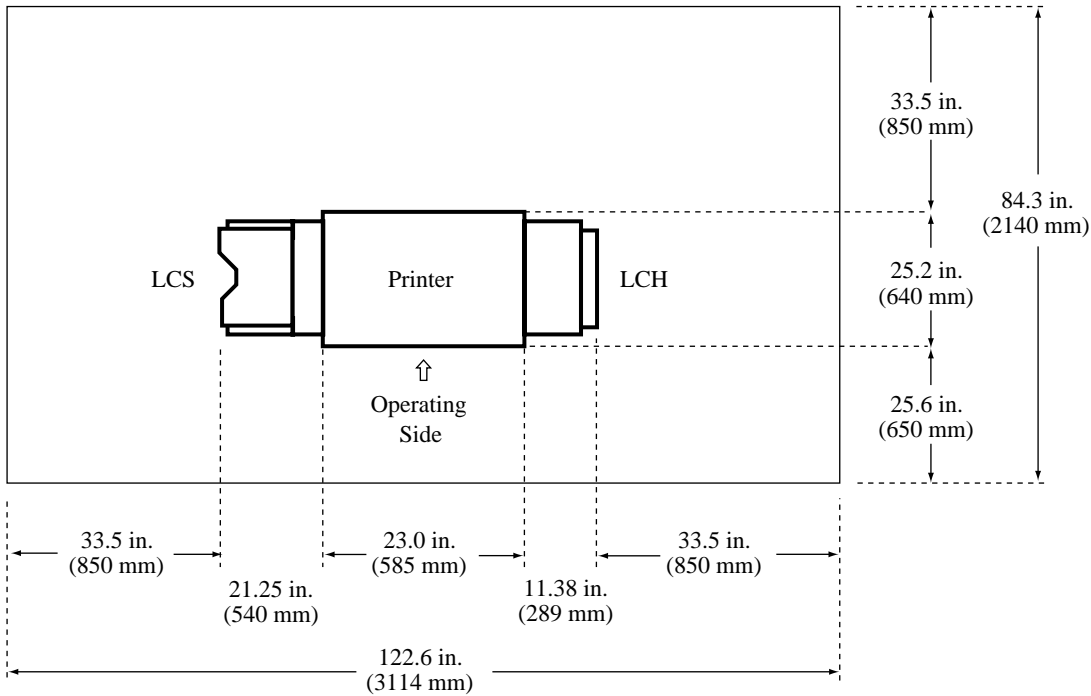

Figure 1-5. LCH, Printer, and LCS Required Service Area Dimensions**1-4.4. LCH Electrical Specifications**

Table 1-9 lists the LCH electrical specifications.

Table 1-9. LCH Electrical Specifications

Item	Specification
Input power	24VDC, supplied from 4060 printer
Power consumption	30VA or less during operation

1-4.5. LCH Environmental Specifications

Refer to Table 1-5 for LCH environmental specifications.

SERVICE MANUAL

1-5. Large-Capacity Stacker (LCS)

1-5.1. LCS Overview

Figure 1-6 shows the user-installable optional Large-Capacity Stacker (LCS) paper handler that connects to the left side of the printer. Model **4060** is for 120V, and model **4060** is for 240V. The LCS can stack up to 2000 sheets of paper (75g/m²).

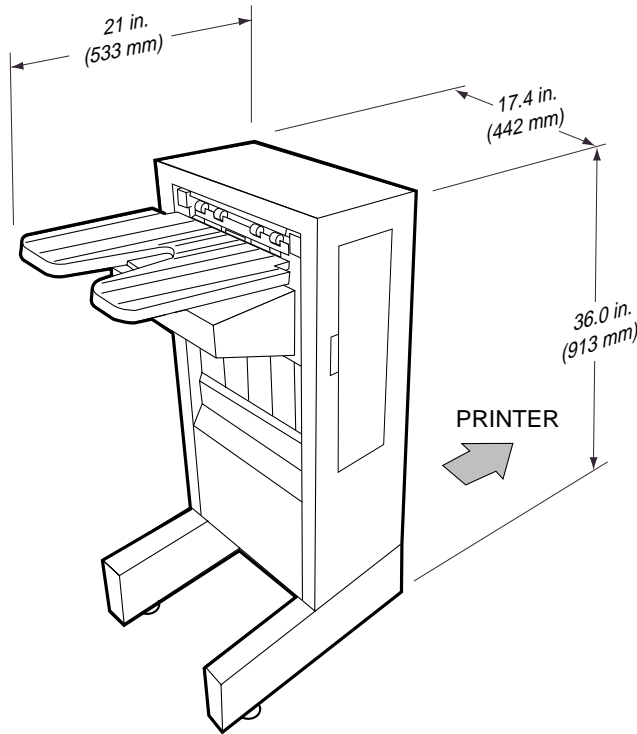

Figure 1-6. Large-Capacity Stacker Physical Dimensions

1-5.2. LCS Paper Handling Specifications

Table 1-10 lists the LCS paper handling specifications.

Table 1-10. LCS Paper Handling Specifications

Item	Specifications	
Processing speed	40 ppm	
Paper	Size	Letter, Legal, Ledger, Executive, A3, A4, A5, B4(JIS) (ISO), and B5 (JIS) (ISO)
	Type	Plain paper, Label paper, Transparency, Bond paper, Pre-punched paper 64 to 90g/m ²

Paper capacity	2,000 sheets (75g/ m2)
----------------	------------------------

1-5.3. LCS Physical Specifications

Table 1-11 lists the LCS physical dimensions, unit weight, and also provides the required service access area dimensions.

Figure 1-6 illustrates these specifications.

Table 1-11. LCS Physical Specifications

Item	Specification		
	Width	Depth	Height
Dimensions	533 mm (21 in)	442 mm (17.4 in)	913 mm (36.0 in)
Weight	About 32 kg (70 lbs)		
Service area	Front	Back	Left
	650 mm (25.6 in)	850 mm (33.5 in)	850 mm (33.5 in)

1-5.4. LCS Electrical Specifications

Table 1-12 lists the LCS electrical specifications.

Table 1-12. LCS Electrical Specifications

Item		Specification	
		4060	4060
Input Power	Voltage	100 to 120 VAC ±10%	200 to 240 VAC ±10%
	Phase	Single-phase	
	Frequency	50/60 Hz 5%	
Power consumption		120 VA or less during operation	
Heat capacity		83 kcal per hour	

1-5.5. LCS Environmental Specifications

Table 1-5 lists the LCS environmental specifications.

SERVICE MANUAL

1-6. Printer Custom Paper Tray

Model 4060 printer custom paper tray is user-installable, optional custom paper tray for the 4060 printer that is compatible and switchable with the standard printer paper tray. The custom paper tray can hold up to 500 sheets (75g/m²) of free sized paper as listed in Table 1-13 specifications.

Table 1-13. Custom Paper Tray Physical Specifications

Paper Size	Inches	Millimeters
Minimum	4.7 x 7.2	120 x 182
Maximum	11.7 x 17	297 x 431.8

Paper size information for the custom tray is selectable. The custom tray also supports the following standard media sizes: Letter, Legal, Ledger, Executive, A3, A4, A5, B4 and B5.

The printing speed from the custom tray is listed in Table 1-2 (measured on and after the second page in continuous printing mode).

1-7. Printer Consumable Specifications

This section explains how the replacement rate is established for the printer consumables. The *4060 User Manual* provides details about consumables kit contents, ordering, and replacement procedures.

Table 1-14 lists the consumables and their respective replacement cycle specifications. Ensure that consumables are replaced at the recommended intervals by monitoring the usage of the printer.

Table 1-14. Consumables and Replacement Cycle

Consumable Item	Replacement cycle
Toner	20,000 images for continuous printing, with 4% coverage for each bottle (average 18,000 images)
Developer	1,600 drum count for each bottle (160,000 images for continuous printing, average 114,000 images)
Drum	2,500 drum count (250,000 images for continuous printing, average 178,500 images)
Transfer Charger	2,500 drum count (250,000 images for continuous printing, average 178,500 images)
Fuser	3,000 page length count (approx. 300,000 images)
Cleaning Roller	40,000 images for continuous printing with 4% coverage (average 36,000 images)
Ozone Filter	3,200 drum count (320,000 images for continuous printing, average 228,000 images)
Collector Bottle	20,000 images for continuous printing with 4% coverage (average 18,000 images)
Printer Pick Roller Kit	5,000 page length count each (approx. 500,000 images)
LCH Pick Roller Kit	5,000 page length count each (approx. 500,000 images)

Notes supporting Table 1-14:

- (1) All the values for replacement cycle shown above are based upon printing on A4 size paper.

- (2) All the listed values are theoretical. The damage due to improper handling, maintenance, papers, environments, and other uncontrollable occasions are not considered in these values.
- (3) All the values for replacement cycle/life shown above depends on printing usage's and conditions:
- **Drum Counts:** The drum counter will increment every 150 seconds (equals 100 images of A4 paper at continuous printing). This counter increments during Warming-up, Intermittent printing and Auto-patrol sequence.

Calculation of the average printed images is based on 1/1.4 of continuous printing; the combination of intermitted printing mode and continuous printing mode.

- **Page Length count:** The page length counter will increase after 100 simplex A4 images are stacked. On duplex printing the page length counter is incremented by two.

For the Printer Pick Roller Kit and the LCH Pick Roller Kit, this counter always increments as simplex printing. When another size paper is used, the counter increments according to the Table 1-15 listed values.

Table 1-15. Page Length Count

Paper size	Increment by 100 sheets at simplex printing	Increment by 100 sheets at duplex printing
Letter	1	2
Legal	2	4
Ledger	2	4
Executive	1	2
A5	1	2
A4	1	2
A3	2	4
B4 (JIS)	2	4
B5 (JIS)	1.5	3

SERVICE MANUAL

1-8. Best Printing Area Specifications

The printed images must be in an area within a 0.5 inch (12 mm) border. Printing outside of this boundary may be of lower quality.

Figure 1-7 shows the best printing area.

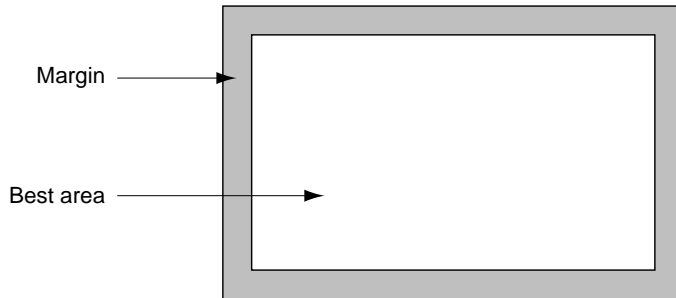

Figure 1-7. Best Printing Area

If data is printed outside the best printing area, you may obtain poor print quality

Figure 1-8 shows the print area of the 4060 printer.

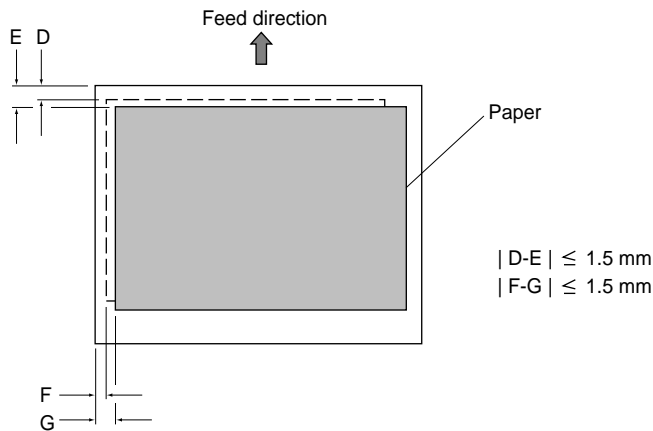

Figure 1-8. Print Area Specifications

If data is printed outside the printing-assured area as listed in Table 1-16 it will cause poor print quality such as:

- Paper feed skew (up to $\pm 2\text{mm}$) that may cause missing characters.
- Bad paper transport that may cause a paper jam.

Table 1-16. Print Area Specifications

	A (mm)	B (mm)		A (mm)	B (mm)
A5	139.6	201.6	LEDGER	271.0	423.4
A4	288.6	201.6	EXECUTIVE	175.75	258.3
A3	288.6	411.6	B5(JIS)	248.6	355.6
LETTER	271.0	207.5	B4 (JIS	173.6	248.6
LEGAL	207.5	347.2			

Figure 1-9 shows the printing position precision.

SERVICE MANUAL

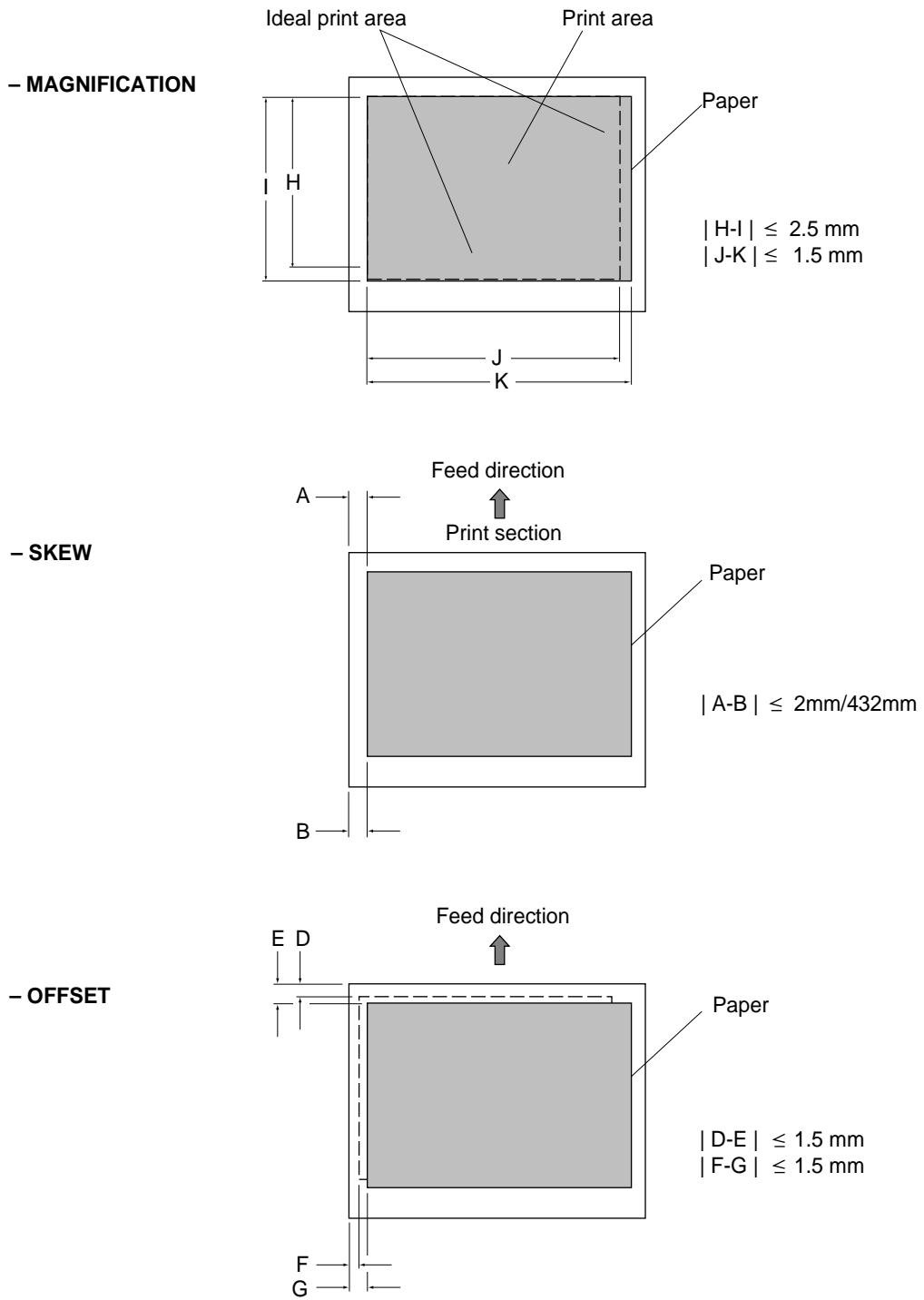

Figure 1-9. Print Positions

1-9. System Configuration Component Locations and Descriptions

1-9.1. Front and Right Side of the Printer

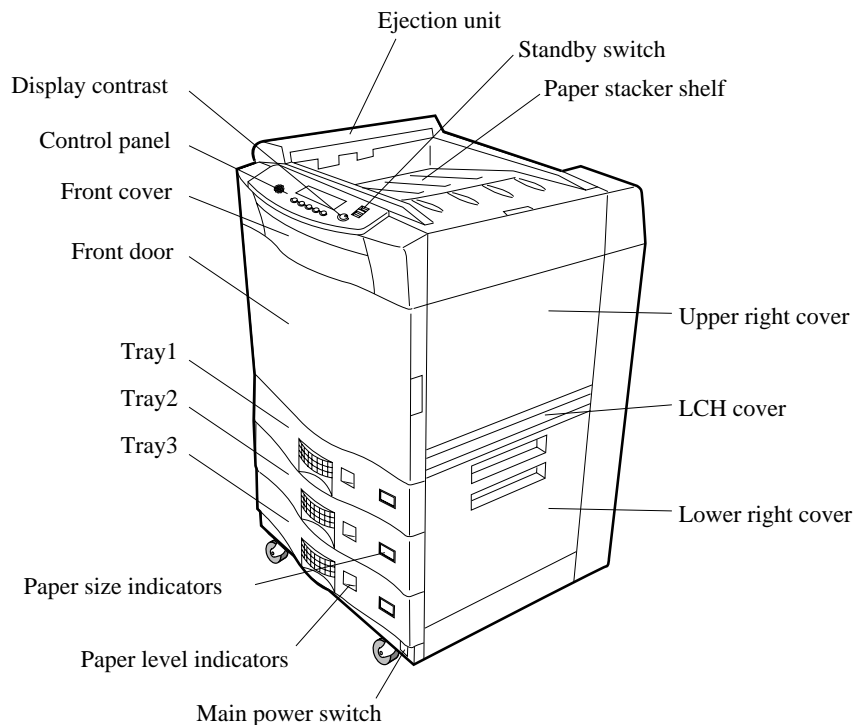

Figure 1-10. Front and Right Side of the Printer

The front of the printer contains the Control Panel and the controls most often used. In Figure 1-10, starting at the Control Panel at the top left and reading clockwise, refer to the following points of interest:

- The **Control Panel** consists of function buttons and a liquid crystal display (also referred to as the LCD display) that presents messages about printer activity.
- The **Display contrast** allows you to adjust the brightness of the LCD display.
- The **Ejection unit** deposits paper on the paper stacker shelf.
- The **Standby switch** readies the printer for printing.
- The **Paper stacker shelf** holds printed pages.
- The **Upper right cover** provides access to the toner and developer areas.

SERVICE MANUAL

- The **LCH cover** should be exchanged to the paper input guide when LCH is installed.
- The **Lower right cover** covers the paper path from the paper trays.
- The **Paper size indicators** show what size of paper is in each tray.
- The **Main power switch** applies power to the printer.
- The **Paper level indicators** tell you the amount of paper in the paper trays.
- The **Trays 1, 2, and 3** hold the printer's standard paper supply. You can also obtain and install optional adjustable custom trays that hold custom sizes of paper.
- The **Front door** provides access to the printer's interior.
- The **Front cover** provides access to the printer's floppy disk drive bay.

1-9.2. Behind the Front Door

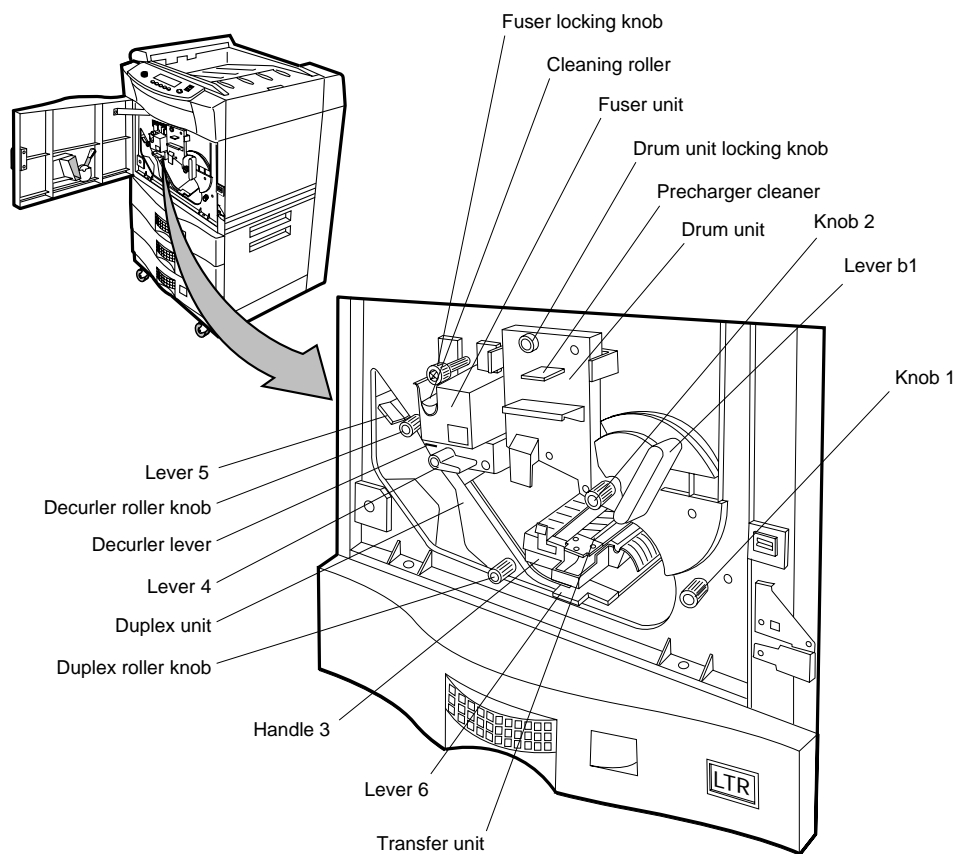
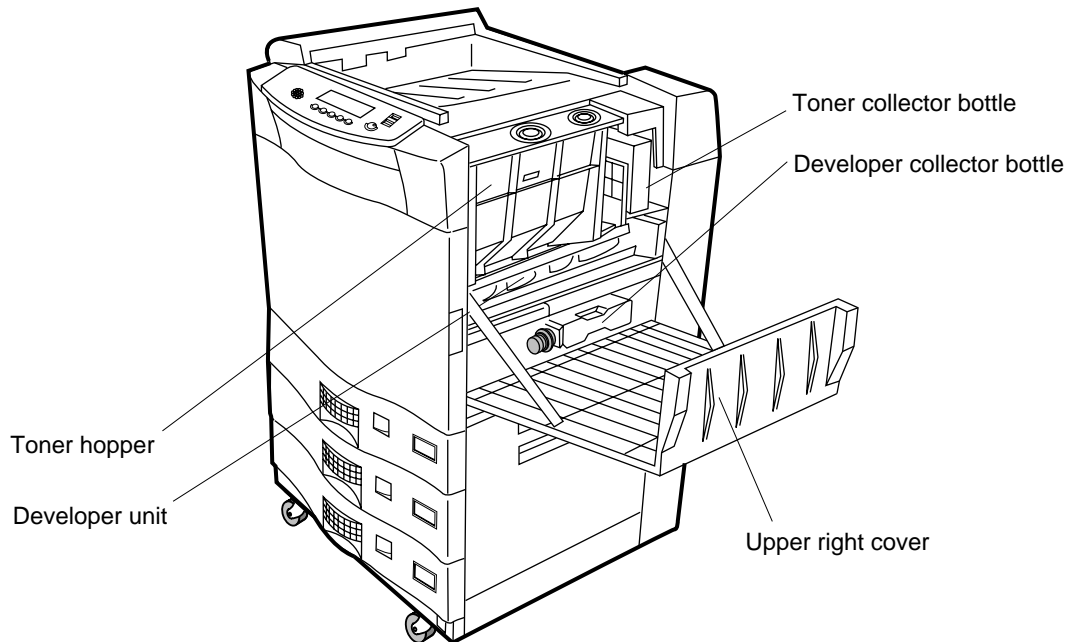

Figure 1-11. Behind the Front Door

When you open the front door of the printer, you see the printer internal components shown in Figure 1-11:

- The **Fuser unit** applies heat and pressure to the paper using upper and lower rollers which fuse the toner to the paper.
- The **Drum unit** contains the precharger, photoconductor drum, precharger cleaner, and toner cleaning unit.
- The **Transfer unit** moves the print image from the drum to the paper and then separates the paper from the drum.
- The **Duplex unit** reverses and transports the paper to the printing unit for double sided printing.
- The **Cleaning roller** lubricates and collects excess toner on the fuser roller.
- The **Drum unit locking knob** secures the drum.
- The **Decurler roller knob** is used to clear paper jams in the immediate area.
- The **Duplex roller knob** is used to clear paper jams in the duplex paper path (during double-sided printing).
- **Knob 1** is used to clear paper jams as the paper exits the paper trays and enters the drum area.
- **Knob 2** is used to clear paper jams as the paper exits the paper trays and enters the drum area.
- **Handle 3** lowers the transfer assembly guide to clear paper jams in the drum area.
- **Decurler lever** provides access to paper in the decurler area to clear paper jams.
- **Lever b1** sets and release the developer unit when the drum or developer unit is removed.
- **Lever 4** releases tension on paper in the fuser area to clear paper jams.
- **Lever 5** provides access to paper in the reverser area to clear paper jams.
- **Lever 6** provides access to paper in the duplexer area to clear paper jams.

1-9.3. Behind the Upper Right Cover**Figure 1-12. Behind the Upper Right Cover**

By opening the upper right cover, you gain access to the printer's consumables, as shown in Figure 1-12:

- The **Toner hopper** contains a supply of toner. The Control Panel notifies you through the controller when the toner supply is running low, and when the printer is out of toner.
- The **Developer unit** contains a supply of developer that, when mixed with toner, forms the visual image on the photoconductor drum. The Control Panel notifies you through controller when the developer life is over.
- The **Developer collector bottle** collects used developer for disposal.
- This bottle is the empty bottle after supplying the new developer.
- The **Toner collector bottle** collects used toner for disposal.

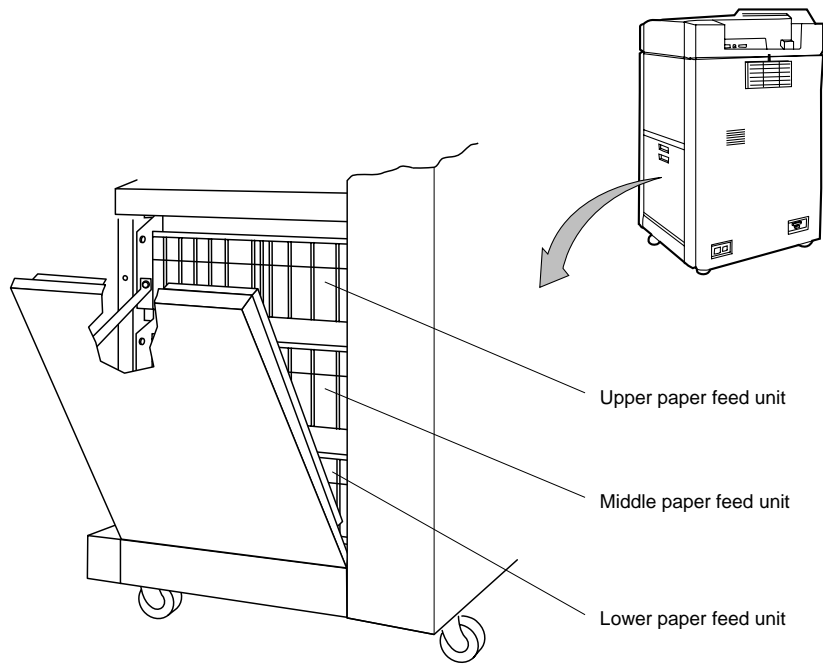
1-9.4. Behind the Lower Right Cover**Figure 1-13. Printer Lower-right Side View**

By opening the lower right cover, you gain access to the paper feed units as shown in Figure 1-13:

- The **Upper, Middle, and Lower paper feed units** feed paper picked from the three paper trays.

SERVICE MANUAL

1-9.5. Rear and Left Side of the Printer

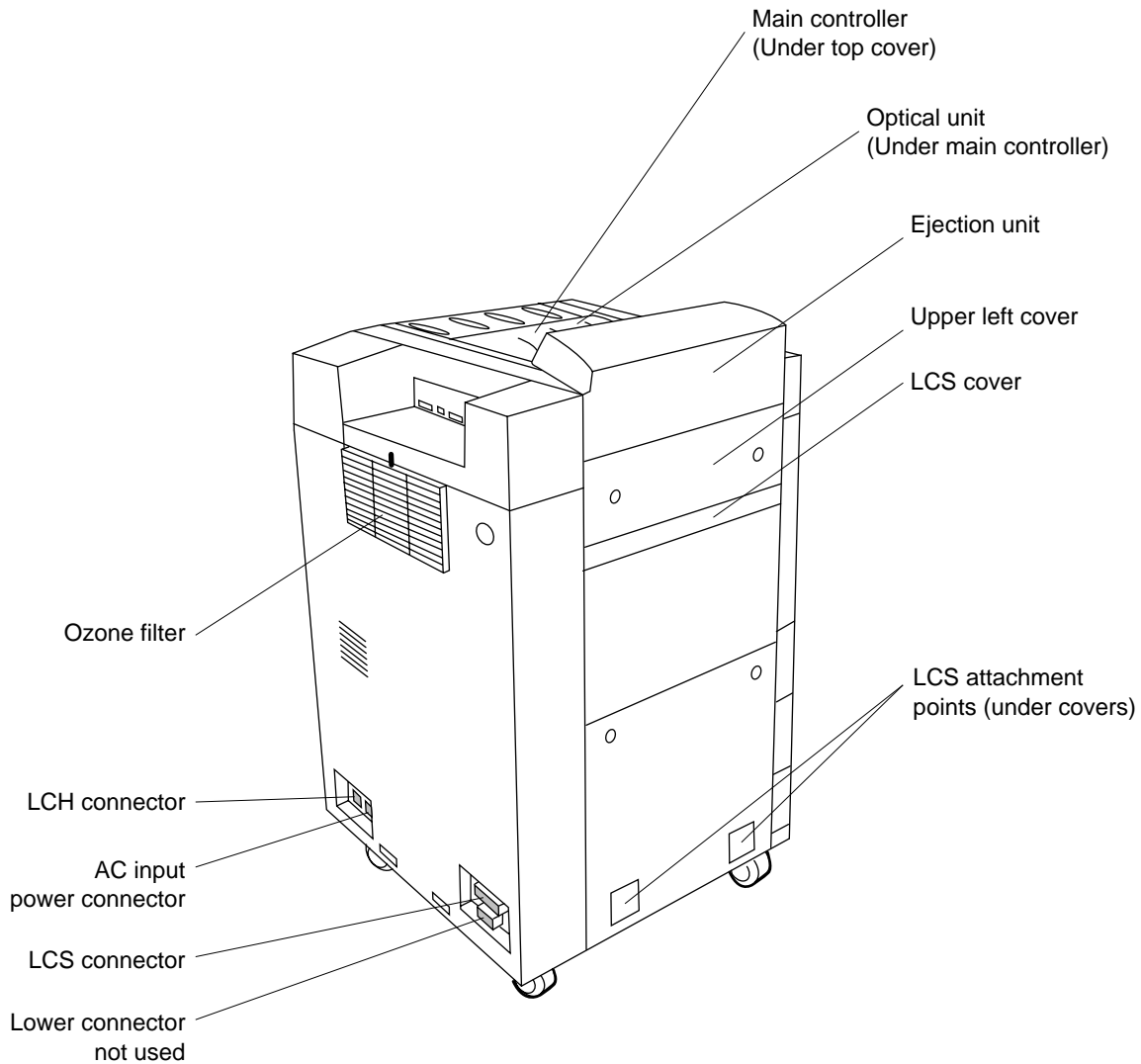

Figure 1-14. Rear and Left Side of the Printer

The rear of the printer has the features shown in Figure 1-14:

- The **Ozone filter** inhibits ozone exhaust.
- The **Ejection unit** ejects the paper to paper stacker and this cover of unit can be opened to clear paper jams in this area.
- The **LCS cover** provides access to the LCS paper path (if installed).

- The LCS cover should be exchanged to the paper exit guide when LCS is installed.
- The **LCS attachment covers** conceal LCS securing hardware.
- The **LCS connector** provides an LCS cable interface (if installed).
- The **Lower connector** is for future upgrades.
- The **AC input power connector** can accept either 120-127 or 200-240 VAC input power (fuser unit must be matched to the input voltage).
- The **LCH connector** provides an LCH cable interface.
- The **Optical unit** (located underneath the main controller) consists of two semi-conductor laser diodes and a rotating mirror spindle motor and lens. The laser generator outputs dual-beams from the laser diodes.

1-9.6. Rear-Inside of the Printer

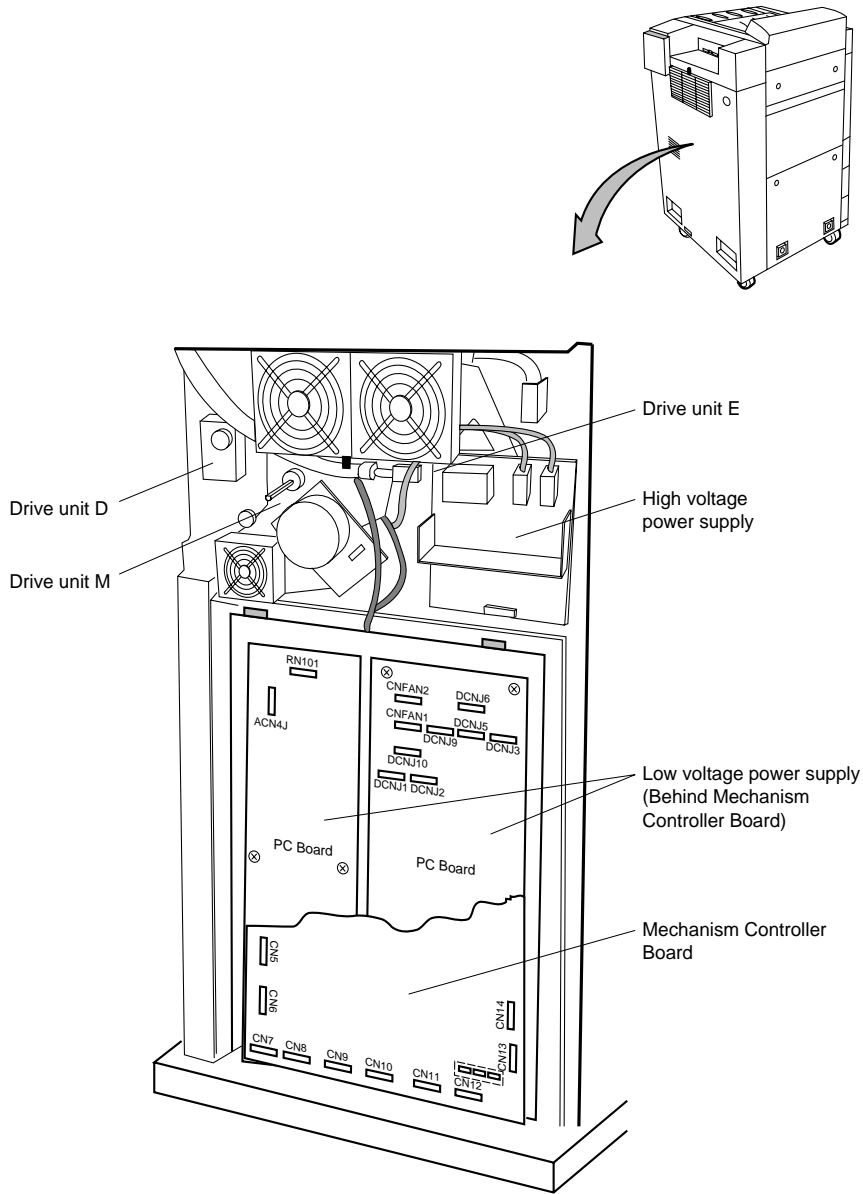

Figure 1-15. Printer Rear Inside View

The rear of the printer has the features shown in Figure 1-15:

- The **Drive unit D** controls toner feed drive screw for toner flow control.
- The **Drive unit E** controls the ejection unit feed belt.

- The **Drive unit M** controls the printer print unit.
- The **High voltage power supply** develops and regulates high voltages to the drum unit components (precharger, photoconductor drum, and cleaning unit), the transfer assembly components (transfer charger and AC charger) and the developer unit.
- The **Low voltage power supply** develops and regulates low voltages used by the motors and the control circuits and so on.
- The **Mechanism controller** contains the control circuits which control the mechanical movement of paper through the printer.

1-9.7. Large-Capacity Hopper (LCH)

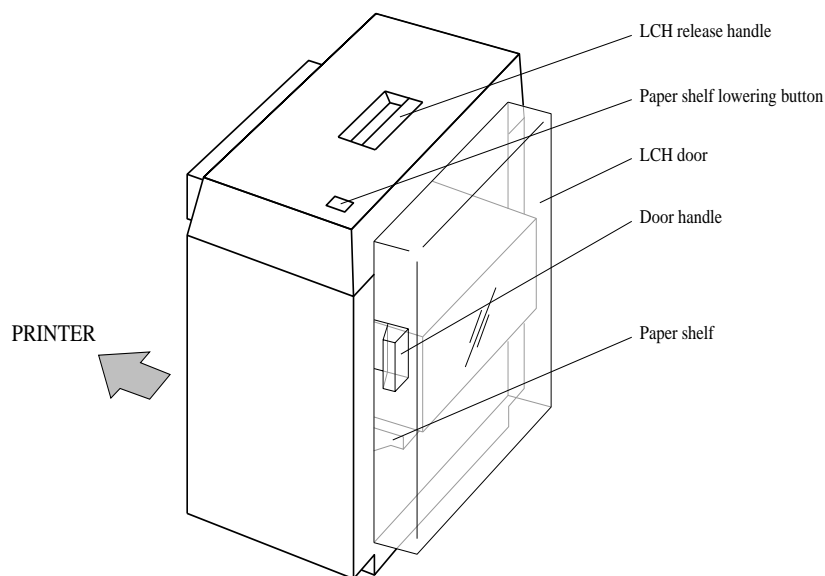

Figure 1-16. Large-Capacity Hopper

The cut sheet printer can also load paper from the optional Large-Capacity Hopper (LCH) accessory (shown in Figure 1-16). The LCH sits on rails attached to the printer and is electrically connected to the printer by a cable, and obtains its power from the printer. The LCH highlights are:

- The **LCH release handle**, when squeezed, detaches the LCH from the printer.
- The **Paper shelf lowering button**, when pressed, lowers the shelf for paper replenishment.

SERVICE MANUAL

- The see-through **LCH door** allows visual inspection of the paper supply.
- The **Door handle** provides easy access to the paper supply.
- The elevator-type movable **Paper shelf** supports the paper supply.

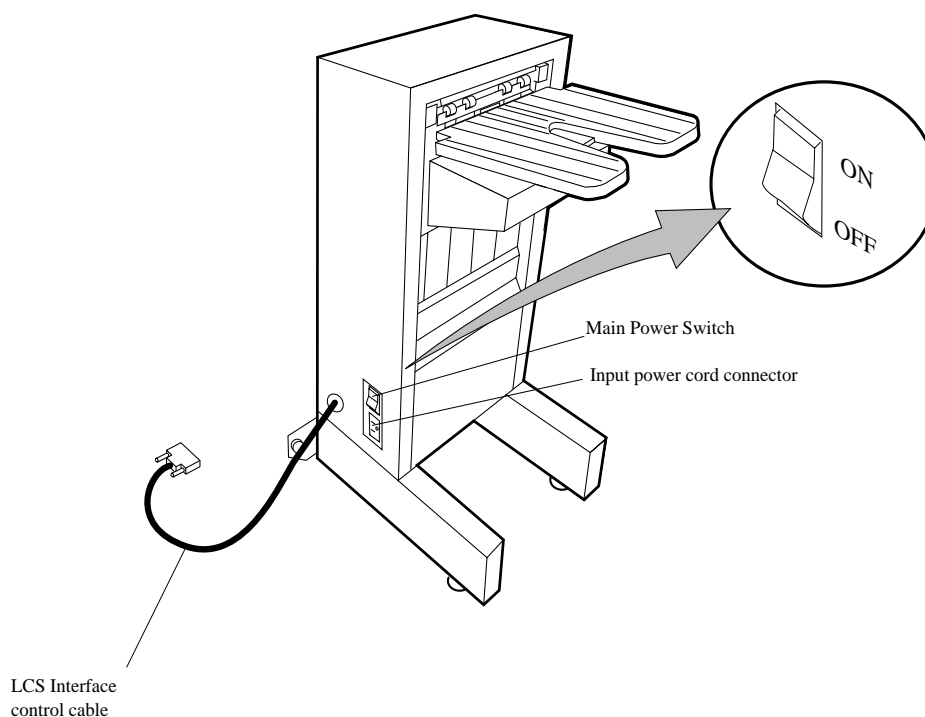
1-9.8. Large-Capacity Stacker (LCS)**Figure 1-17. Large-Capacity Stacker**

The cut sheet printer can stack paper onto the optional Large-Capacity Stacker (LCS) accessory stacker (shown in Figure 1-17). The LCS uses a standard power cord that may be plugged into any wall outlet. The LCS is mechanically connected to the printer and is electrically connected to the printer by a cable. Power is controlled by the ON/OFF switch.

SERVICE MANUAL

1-10. Printer Component Block Diagram

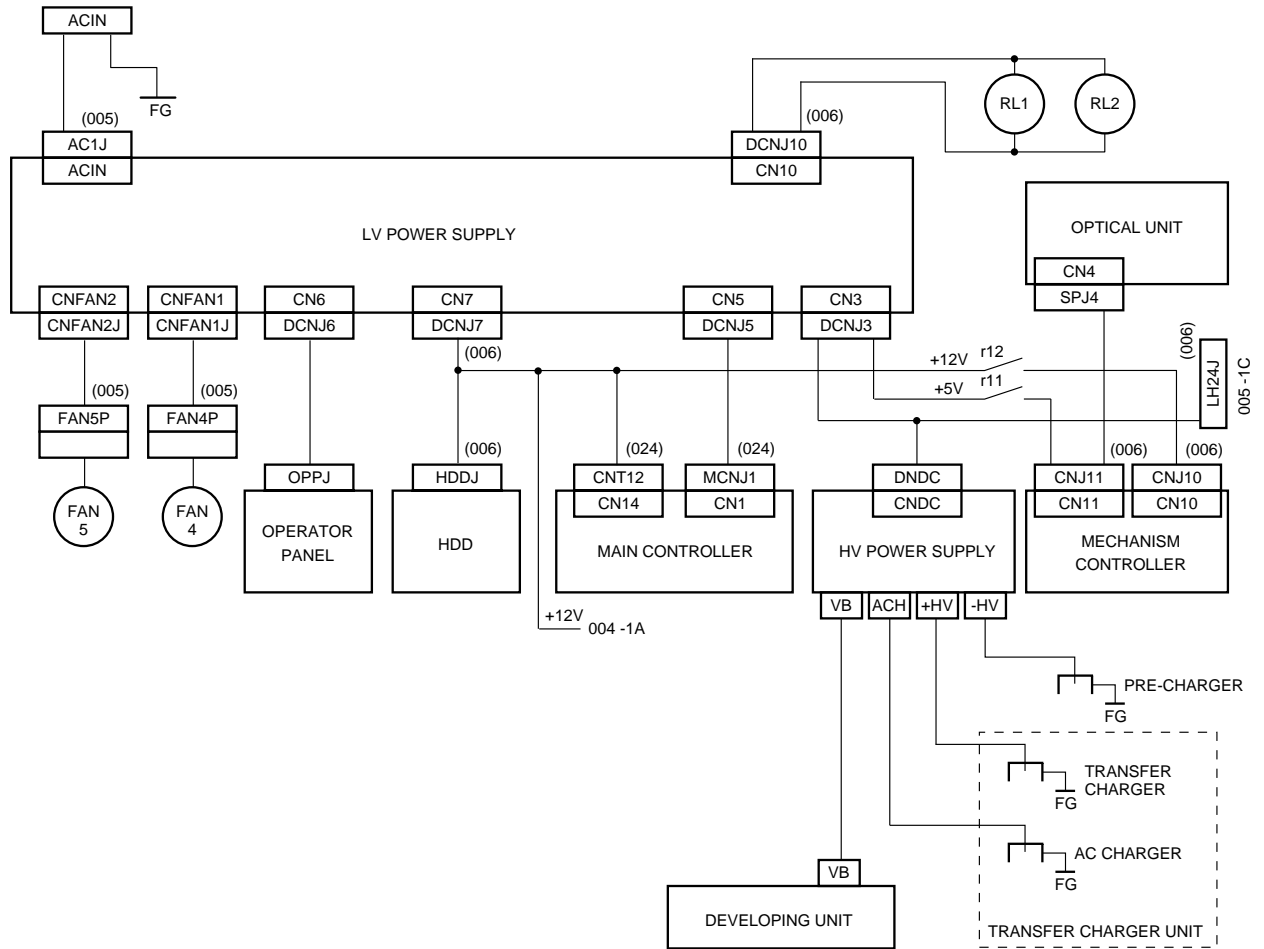

Figure 1-18. Printer Component Block Diagram (Sh 1 of 4)

SERVICE MANUAL

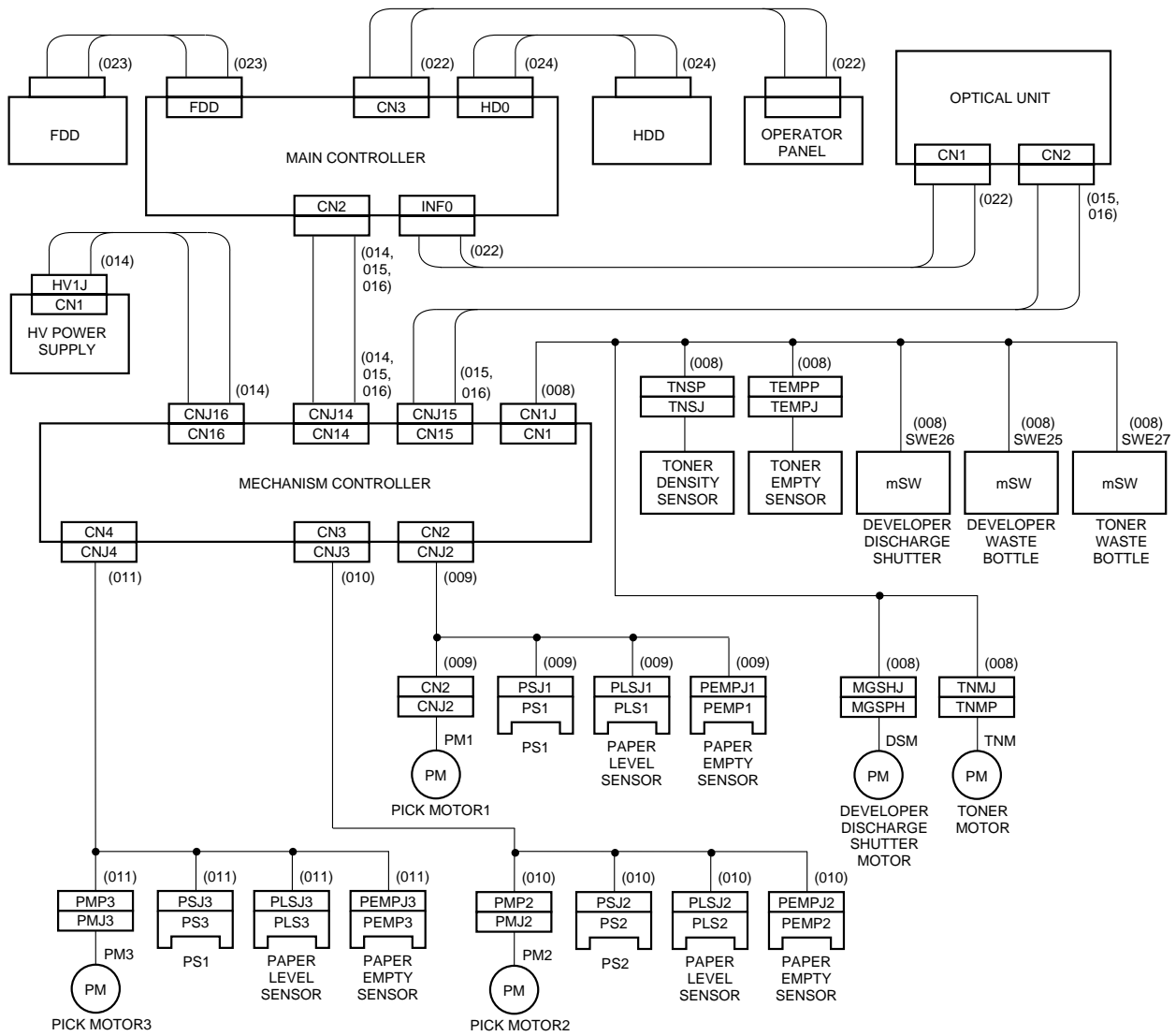

Figure 1-18. Printer Component Block Diagram (Sh 2 of 4)

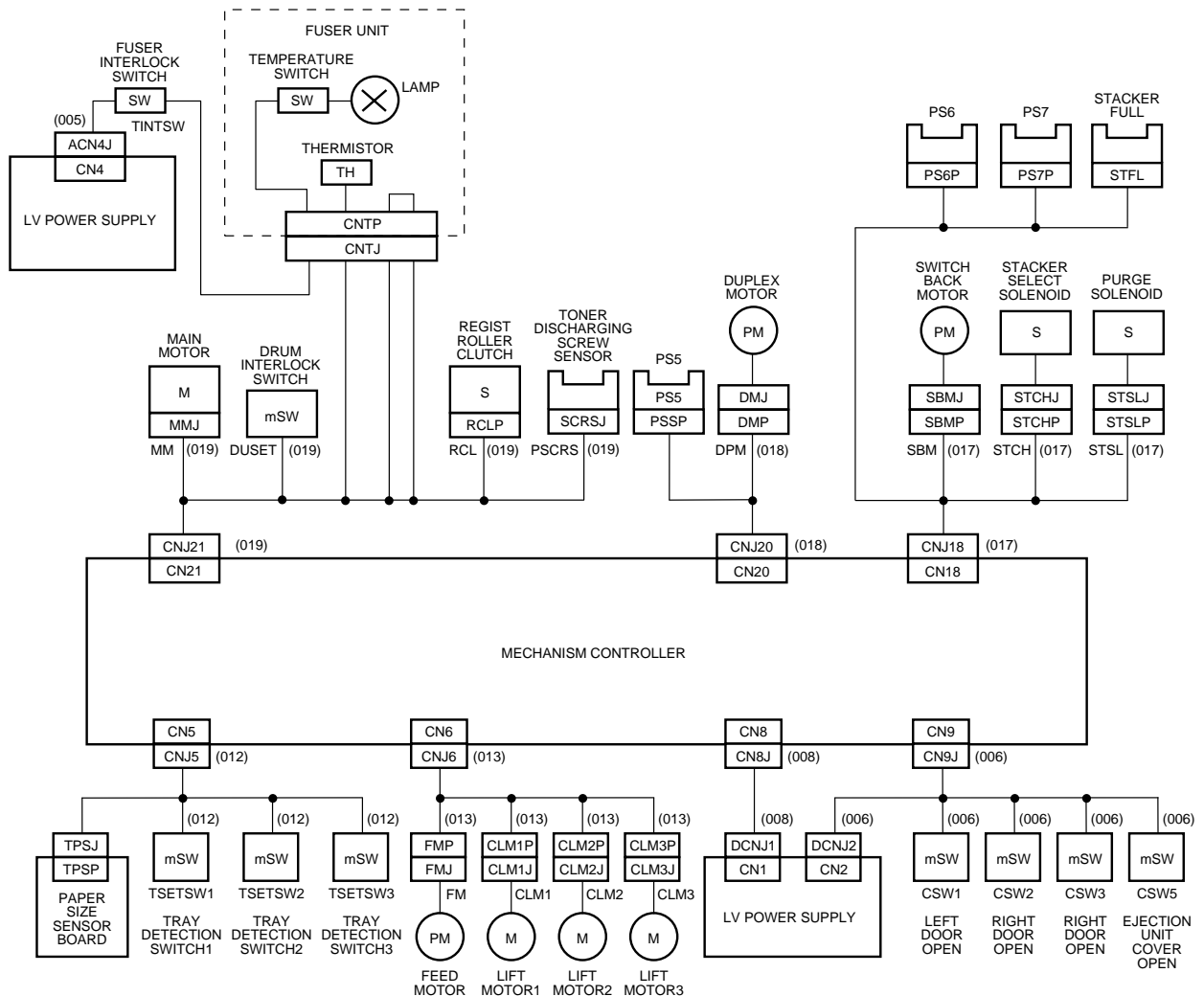

Figure 1-18. Printer Component Block Diagram (Sh 3 of 4)

SERVICE MANUAL

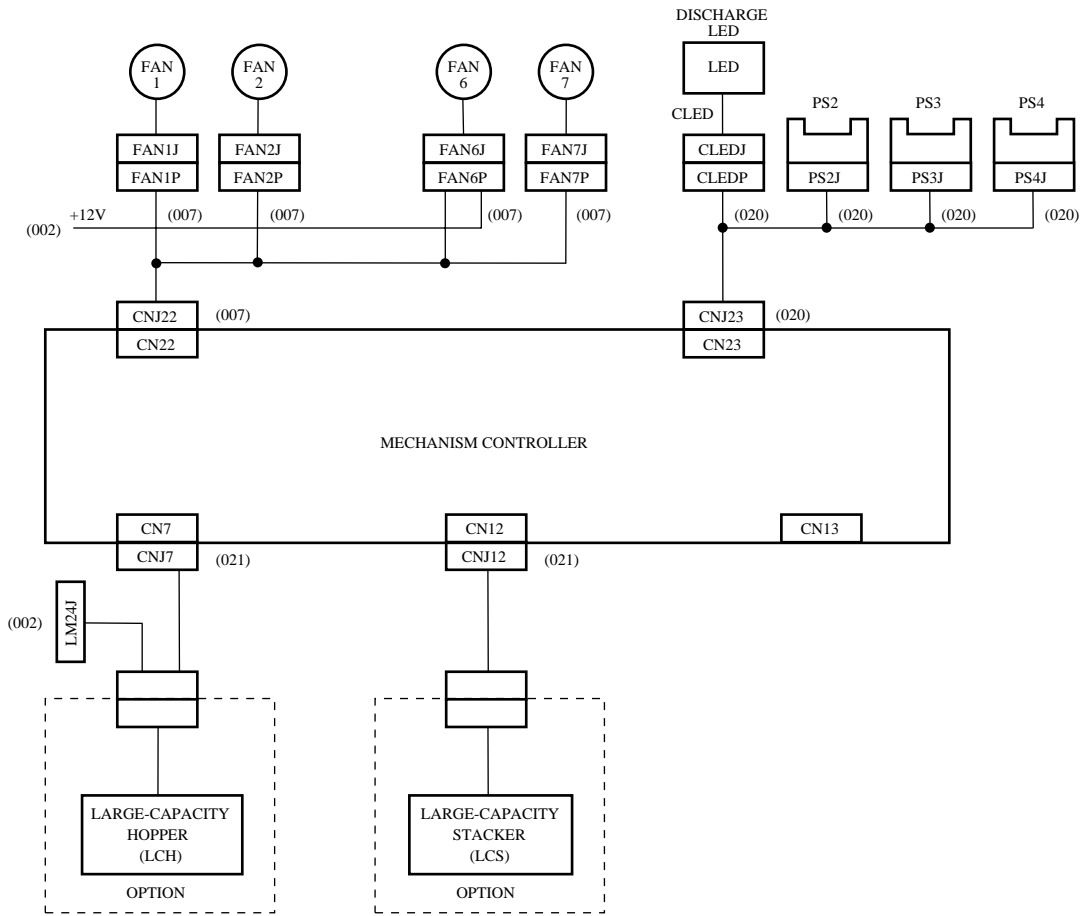

Figure 1-18. Printer Component Block Diagram (Sh 4 of 4)

1-11. Safety and Regulatory Information

The safety and regulatory information for the 4060 printer is located in the *4060 User Manual*.

1-12. Servicing Approach

The printer is serviced by:

- (1) Understanding the layout and specifications of the printer and the associated options as described in this chapter.
- (2) Understanding the printer theory of operation described in chapter 2.
- (3) Using the information about loading and using the main program with the operator panel read-outs as described in chapter 3.
- (4) Performing general troubleshooting techniques provided in chapter 4.
- (5) Performing detailed troubleshooting using specific alarm or condition specific flow charts provided in chapter 5.
- (6) Performing failed field replaceable unit (FRU) removal and replacement procedures provided in chapter 6. For FRUs whose repair procedures are obvious because they are simple are not documented here but repair instructions may be provided in the replacement FRU package, depending on complexity of repair.
- (7) Referencing the printer, LCH, and LCS illustrated parts breakdown illustrations and associated part listings in chapter 7 and using printer wiring diagrams in appendix A.

SERVICE MANUAL

1-13. Interior Label

This product is a Class I laser product.

The warning labels shown are located outside on the optical unit.

Caution

Use of controls or adjustment of performance
for procedures not specified herein may
result in hazardous radiation exposure.

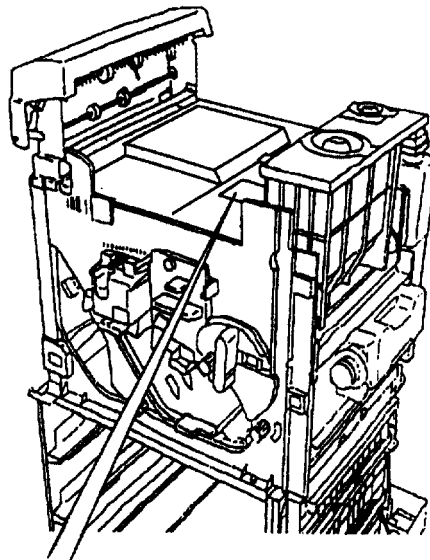

		INVISIBLE LASER RADIATION UNSICHTBARE LASERSTRAHLUNG 不可視レーザー光
DANGER	INVISIBLE LASER RADIATION WHEN OPEN. AVOID EXPOSURE TO BEAM	
DANGER	RAYONNEMENT LASER INVISIBLE EN CAS D'OUVERTURE. EXPOSITION DANGEREUSE AU FAISCEAU.	
GEFAHR	UNSICHTBARE LASERSTRAHLUNG TRITT AUS. WENN DECKEL GEÖFFNET IST ! NICHT DEM STRAHL AUSSETZEN !	
PELIGRO	RADIACION DE LASER INVISIBLE AL ABRIR. NO MIRAR NI TOCAR LA VIGA DIRECTAMENTE.	
FARA	USYNLIG LASER-STRÅLNING NÄR DENNA DEL ÄR ÖPPNAD STRÅLEN ÄR FARLIG	
危険	ここを開くと不可視レーザー光が出ます。 ビームを直接見たり、触れたりしないこと。	

CHAPTER 2 THEORY OF OPERATION

Chapter 2 contents include:

Section

2-1	Introduction.....	2-3
2-2	Overview of Printing Process	2-3
	2-2.1 Mechanical Operation	2-3
	2-2.2 Video Data Control	2-6
	2-2.3 Developer Replacement	2-11
2-3	Paper Feed Operation.....	2-16
	2-3.1 Operational Timing Charts	2-16
2-4	Printer Power	2-25
	2-4.1 Low Voltage Power Supply Block Diagram	2-25
	2-4.2 High Voltage Power Supply Block Diagram	2-27
	2-4.3 Power-on Sequence Timing Chart	2-30

2-1. Introduction

This chapter describes the 4060 printer printing process with overviews of the mechanical components, functions, and timing sequences.

2-2. Overview of Printing Process

This section describes the printing process through an overview of the mechanical and functional operations. Chapter 1 provides locational views of these components.

The printing process section consists of the following mechanical components:

- Photoconductor drum
- Precharger
- Optical unit
- Developer unit
- Transfer unit
- LED erase unit (also called a discharging lamp)
- Cleaning unit
- Fuser unit

NOTE

The photoconductor drum, precharger, and cleaning unit (except for discharging lamp) are assembled into the drum.

2-2.1. Mechanical Operation

The paper is fed from the paper tray and is processed in each component of the printer as follows:

1. Precharger

The precharger charges all the surface of the photoconductor drum evenly with approximately -600V by the grid control.

2. Optical unit

The optical unit emits two modulated laser beams to the surface of the photoconductor drum to reduce the electric potential to approximately -100V (or less). The electric potential on the part to which the beam was not emitted remains unchanged. Figures 2-1, 2-2, and 2-3 illustrate the optical unit operations.

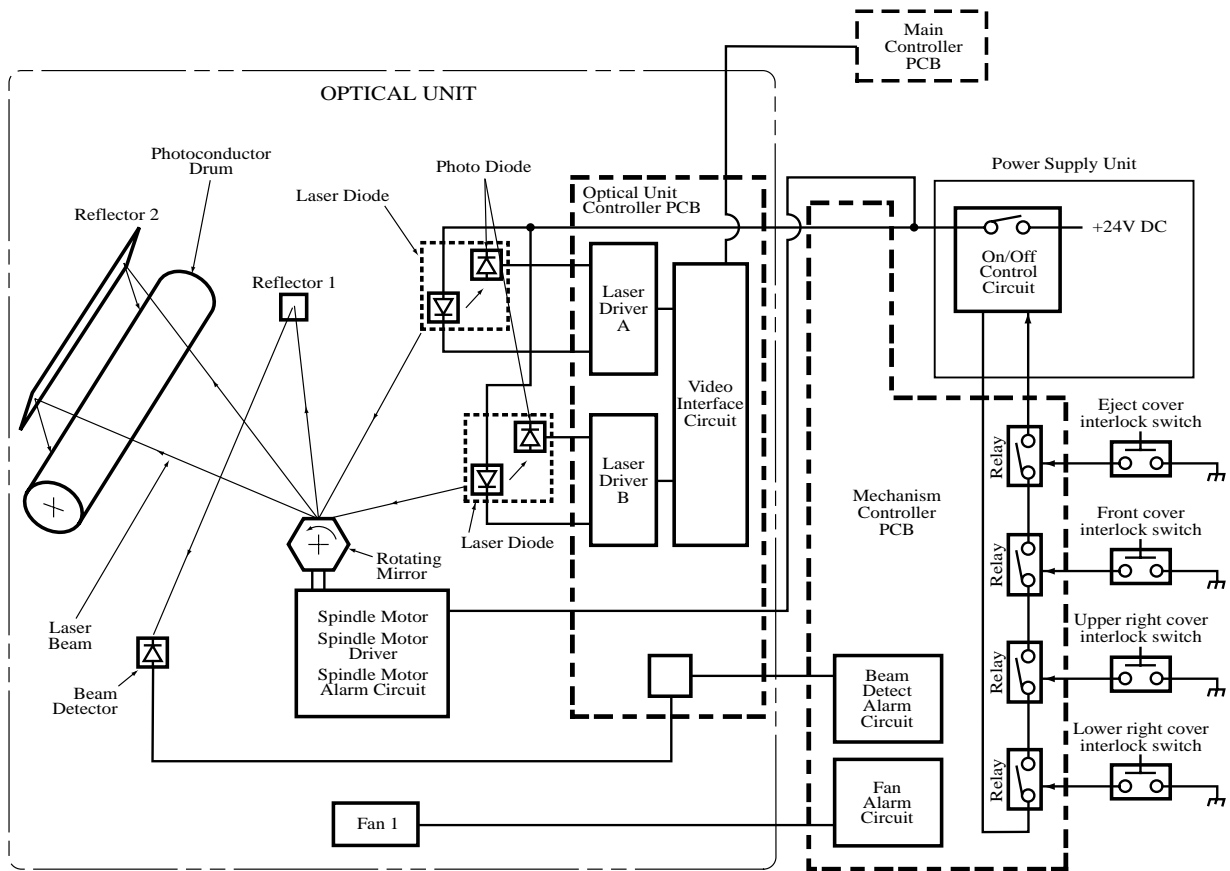

Figure 2-1. Dual-beam Optical Unit Functional Diagram

SERVICE MANUAL

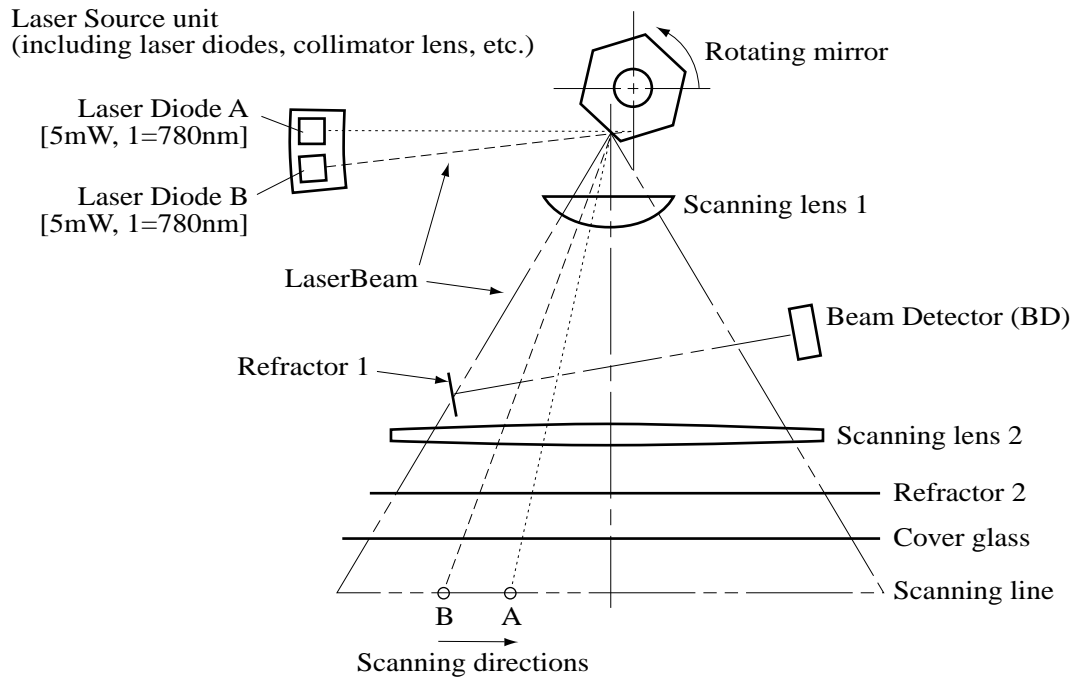

Figure 2-2. Optical Unit Laser Scanning System

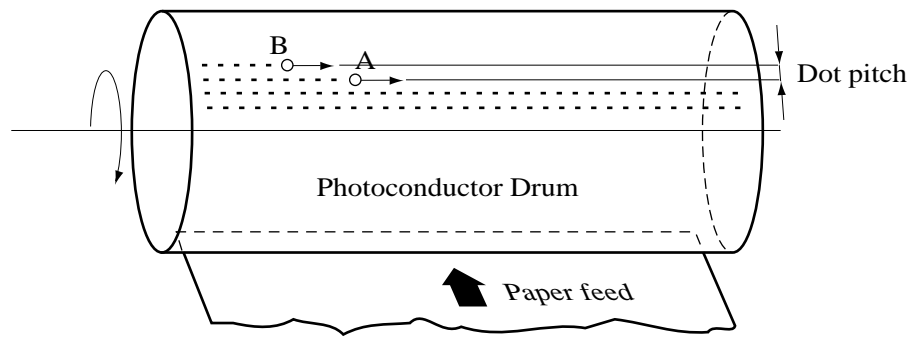

Figure 2-3. Laser Scanning of Photoconductor Drum

3. Developer unit

The developer unit stirs two-component developer (toner and carriers) to generate frictional electricity. The charged toner sticks to the laser-applied area (-100 V) on the photoconductor drum.

4. Transfer assembly

The transfer assembly transfers a toner image from the photoconductor drum to a paper. This transfer is caused by the corona charge from the back side of the paper by the positive charge. The paper sticks to the photoconductor drum electrostatically.

The AC discharger separates the paper from the photoconductor drum by electrical neutralization and by the natural stiffness of paper.

5. LED erase unit (lamp discharger)

The LED erase unit removes the electrostatic charge remaining on the photoconductor drum.

6. Cleaning unit

The remaining toner is removed with a cleaning blade. The next cycle of the printing operation begins.

7. Fuser unit

The fuser pressure roller heats and presses the paper. The roller is heated by a halogen lamp in the roller. The toner on the paper is fused and the toner image is fixed.

2-2.2. Video Data Control

Function:

(1) VIDEO

VIDEO is serial video data.

(2) BD

BD is a pulse signal that indicates the laser-beam scan start position.

The controller uses the BD signal as the video synchronization signal in the laser-beam main scan direction. The VIDEO signal output in each scan period is determined at the falling edge of the BD signal.

(3) VR

VR is the VS request signal that is to be sent from the printer to the controller.

(4) VS

VS is the video synchronization signal in the paper feeding (secondary scanning) direction.

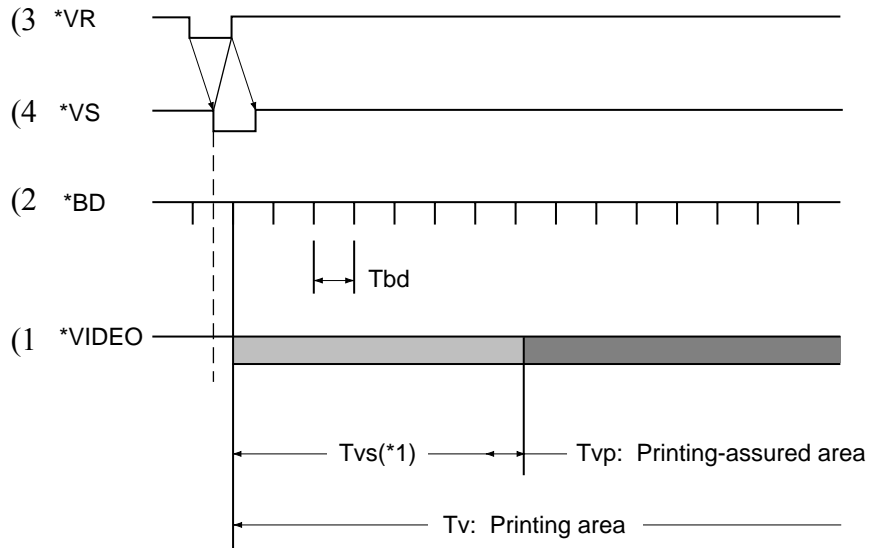

Figure 2-4. Printing Control in Paper Transport Direction (VIDEO Control)

Note: The T_{vs} time is equivalent to the distance of 5 millimeters.

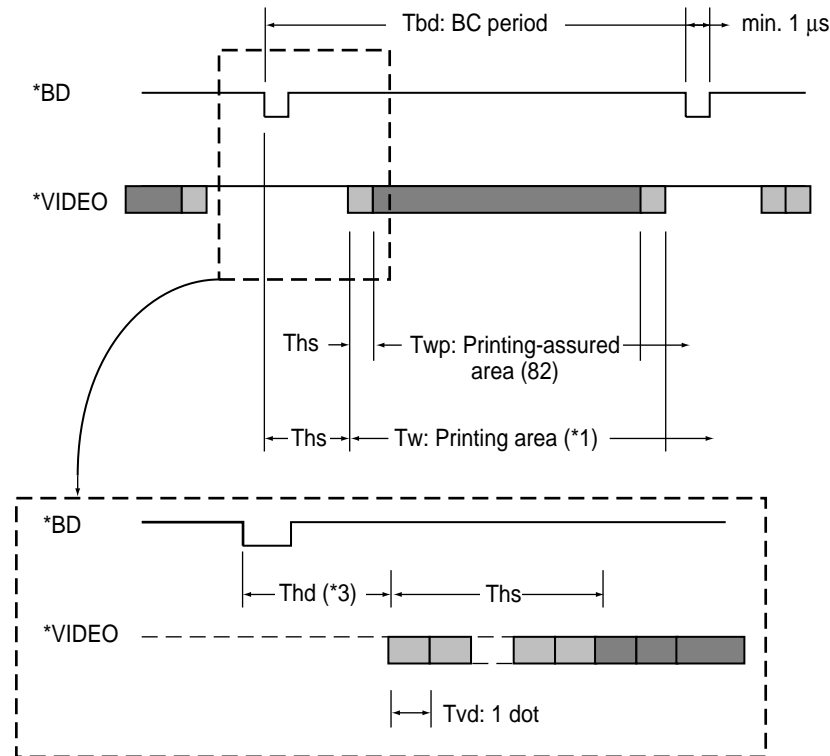

Figure 2-5. Printing Control In Beam Main Scan Direction (VIDEO Control)

Notes:

1. The Tw time is equivalent to the printing paper width.
2. The printing-not-assured area in the paper width direction begins at a position 5 millimeters from the left edge of the paper. This area ends at a position 5 millimeters from the right edge of the paper.
3. The variation of the Thd width in each line scan should not exceed 1/8 of the video-signal l-dot time width Tvd.

Table 2-1. VIDEO Signal Control Parameters (Not Depending On Paper Size)

Printing resolution	Tvs (ms)	Tbd (μs)	Tvd (ns)	Ths (μs)
600 dpi	13.89	235.195	135.821 to 222.222	2.005 to 3.281

SERVICE MANUAL**Table 2-2. VIDEO Signal Control Parameters (600 dpi, Depending On Paper Size)**

Paper size W × V (mm)	Printing in 600 dpi <TYPE A>				
	Tv (ms)	Tvp (ms)	Thd (μs)	Tw (μs)	Twp (μs)
A3 portrait 297 × 420	2333.37 (9,921 lines)	2277.86 (9,685 lines)	2.801 to 3.667 (165 dots)	119.115 to 155.911 (7,016 dots)	115.108 to 150.667 (6,780 dots)
A4 landscape 297 × 210	1166.80 (4,961 lines)	1111.06 (4,724 lines)	2.801 to 3.667 (165 dots)	119.115 to 155.911 (7,016 dots)	115.108 to 150.667 (6,780 dots)
A5 portrait 148 × 210	1166.80 (4,961 lines)	1111.06 (4,724 lines)	32.682 to 42.778 (1,925 dots)	59.354 to 77.689 (3,496 dots)	55.347 to 72.444 (3,260 dots)
Letter landscape 279.4 × 215.9	1199.49 (5,100 lines)	1143.99 (4,864 lines)	6.333 to 8.289 (373 dots)	112.053 to 146.667 (6,600 dots)	108.045 to 141.422 (6,364 dots)
Legal portrait 215.9 × 355.6	1975.64 (8,400 lines)	1920.13 (8,164 lines)	19.066 to 24.956 (1,123 dots)	86.586 to 113.333 (5,100 dots)	82.579 to 108.089 (4,864 dots)
Ledger portrait 279.4 × 431.8	2398.99 (10,200 lines)	2343.48 (9,964 lines)	6.333 to 8.289 (373 dots)	112.053 to 146.667 (6,600 dots)	108.045 to 141.422 (6,364 dots)
Executive portrait 266.7 × 184.15	1027.8 (4,370 lines)	972.26 (4,133 lines)	8.676 to 14.194 (511 dots)	106.959 to 175.000 (6,300 dots)	102.935 to 168.417 (6,063 dots)
B4 (JIS) portrait 257 × 364	2022.21 (8,598 lines)	1966.70 (8,362 lines)	10.832 to 14.178 (638 dots)	103.072 to 134.911 (6,071 dots)	99.064 to 129.666 (5,835 dots)
B5 (JIS) portrait 182 × 257	1427.87 (6,071 lines)	1372.36 (5,835 lines)	25.874 to 33.867 (1,524 dots)	72.987 to 95.533 (4,299 dots)	68.980 to 90.289 (4,063 dots)
Custom tray 1 120 to 297 x 182 to 215.9	1011.10 to 1194.49 (4299 to 5100 lines)	1143.99 (4864 lines)	42.104 to 2.801 68.889 to 4.583 (2480 to 165 dots)	40.101 to 119.115 65.611 to 194.889 (2362 to 7016 dots)	36.077 to 115.108 59.028 to 188.333 (2125 to 6780 dots)
Custom tray 2 120 to 297 x 216 to 431.8	1194.49 to 2398.99 (5100 to 10,200 lines)	2348.48 (9964 lines)	42.104 to 2.801 68.889 to 4.583 (2480 to 165 dots)	40.101 to 119.115 65.611 to 194.889 (2362 to 7016 dots)	36.077 to 115.108 59.028 to 188.333 (2125 to 6780 dots)

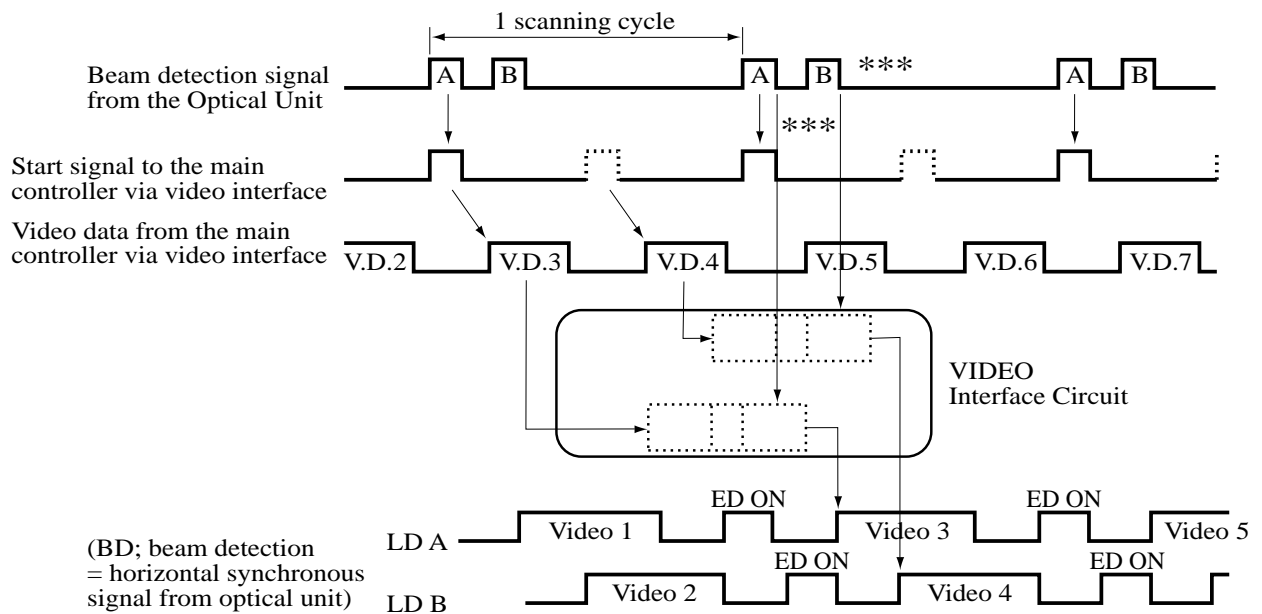

Figure 2-6. Sequence Control of VIDEO Data Timing Diagram

SERVICE MANUAL

2-2.3. Developer Replacement

The operator must replace the developer by using the developer replacement command DVEXC. The developer replacement request (MESG) and developer end life (OPC) are reset by completing the developer replacement.

Replace the developer in the following procedure:

Developer replacement start direction → Developer ejection and supply → Developer replacement end direction

The printer status during developer replacement is indicated with PRSQ1 code (\$99 to \$9F). In the following explanations, PRSQ1 = \$99 to \$9F indicates developer replacement state, and other PRSQ1 values indicate normal states.

(1) Developer replacement execution command = \$98

If any error shown in Figure 2-7 "Developer Replacement Operation Suppression Errors" exists, the command is rejected by CMDER and CME.

Any cover open (EMSR2: bit 5, bit 6, bit 7)	
Developer unit interlock (EMSR3: bit 0)	
Drum interlock (EMSR3: bit 1)	
Toner motor alarm (SVC = \$50)	Internal fan alarm 1 (SVC = \$A0)
Screw rotation alarm (SVC = \$51)	Internal fan alarm 2 (SVC = \$A1)
Developer ejection alarm (SVC = \$52)	Internal fan alarm 6 (SVC = \$A5)
Main motor alarm (SVC = \$69)	Internal fan alarm 7 (SVC = \$A6)
Communication alarm (SVC = \$B3)	EEPROM alarm (SVC = \$B4)
High-voltage power supply alarm (SVC = \$6F)	

Figure 2-7. Developer Replacement Operation Suppression Errors

(1) *Developer replacement procedure start: PARA1 = \$01*

[Function]

- The developer replacement execution command directs the printer to start developer replacement.

[Printer operation]

- All the operations of the printer mechanism stop.
- Any errors other than the developer replacement operation suppression error are reset.
- PRSQ1 is set to \$99.

[Restrictions]

- This command is valid when the PRSQ1 value is one of the following:
 - \$00 (out of operation)
 - \$30
 - \$31 (initialization)
- If PRSQ1 is a value of \$99 to \$9F, the command is invalid, but is not rejected.
- If PRSQ1 is other than the above values, the command is rejected.
- If the developer bottle is not set, EMS (EMSR3, bit 5) is set and the command is rejected.

(2) *Developer ejection start: PARAI = \$02*

[Function]

- The developer ejection start command directs the printer to start the developer ejection operation.

[Printer operation]

- During the developer ejection operation, PRSQ1 is set to \$9B.

[Restrictions]

- The developer ejection start command is valid when the PRSQ1 value is one of the following:
 - \$99 (developer replacement start)
 - \$9A (developer ejection operation stop)
- If PRSQ1 is \$9B (developer ejection operation), the developer ejection start command is invalid, but is not rejected.
- If PRSQ1 is other than the above values, the command is rejected.

(3) *Developer pouring end: PARAI = \$04*

[Function]

- The developer pouring end command directs the printer to end the new developer pouring operation.

[Printer operation]

- The printer transfers to PRSQ1=\$97 when the developer replacement procedure end command.

SERVICE MANUAL

[Restrictions]

- The developer pouring end command is not valid when PRSQ1 is other than \$9E.
- If PRSQ1 is a value other than those above, the command is rejected.

(4) *Developer replacement procedure end: PARAI = \$06*

[Function]

- The developer replacement procedure end command directs the printer to end the developer replacement operation.

[Printer operation]

- When PRSQ1 is \$9F (developer replacement completion), the developer replacement request (MESG) and developer life end state (OPC) are reset. Moreover, the specified developer life value is placed in the developer life management counter.
- When PRSQ1 is \$9F, the printer starts automatic toner density adjustment.

[Restrictions]

- The developer replacement procedure end command is valid when PRSQ1 is \$99, \$9C, \$9F or \$00.
- If PRSQ1 is a value other than those above, the command is rejected.

(2) Developer replacement status

The developer replacement operation status is indicated with PRSQ1 code \$99 to \$9F. During developer replacement operation, detection of errors other than the developer replacement operation suppression error is masked.

(1) *Developer replacement start: PRSQ1 = \$99*

- \$99 indicates that the printer received a developer replacement start command and is waiting for another command.
- In this state, the following developer replacement commands can be accepted and executed:
 - Developer ejection start command
 - Developer replacement procedure end command
- When the printer power is turned off then on in this state, the printer is set to the normal state.

(2) *Developer ejection stop: PRSQ1 = \$9A*

- \$9A indicates that the developer ejection operation stopped. This stop occurs when a

developer replacement operation suppression error was detected or the printer power was turned off during developer ejection operation.

- The only developer replacement command that can be accepted and executed in this status is the developer ejection start command.
 - When the printer power is turned off then on in this state, the printer is set to the developer ejection stop state.
- (3) *Developer ejection operation: PRSQI = \$9B*
- \$9B indicates that the printer received a developer ejection start command and is ejecting developer.
 - The developer ejection operation terminates after about 30 seconds unless a stop cause occurs (developer replacement operation suppression error). Then, the printer goes to the developer ejection operation completion state.
 - During the developer ejection operation, any developer replacement commands cannot be accepted.
 - When the printer power is turned off then on in this state, the printer is set to the developer ejection stop state.
- (4) *Developer ejection completion: PRSQI = \$9C*
- \$9C indicates that the printer completed the developer ejection operation and is waiting for pouring the new developer.
 - The upper right door is opened in this state, then PRSQ1 is set to \$9E, waiting for supplying the new developer.
 - When the printer power is turned off then on in this state, the printer is set to the developer ejection completion state.
- (5) *Developer ejection-supply operation: PRSQI = \$9E*
- \$9E indicates that the printer is executing the developer ejection-supply operation.
- (6) *Developer bottle replacing: PRSQI = \$97*
- \$97 indicates that the developer bottle is on replacing.
 - When the printer power is turned off in this status and is turned on again, the printer keeps this status.
- (7) *Developer ejection-supply completion: PRSQI = \$9F*
- \$9F indicates that the printer completed the developer ejection-supply operation and is waiting for another command.
 - The only developer replacement commands that can be accepted and executed in this

status is the developer replacement end command.

- When the printer power is turned off then on in this status, the printer resets the developer replacement request (MMSG) and developer life end state (OPC). The printer also places the specified developer life value into the developer life management counter. Then, it starts automatic toner density adjustment.

(3) Toner density control slice level setup

When a developer replacement end command is completed, the printer initializes the mechanism unit. At the same time, the printer sets the toner density control slice level for the newly supplied developer.

During the slice level processing, the mechanism unit initialization continues for about 90 seconds.

Sequence 1 through 8 lists the developer replacement status transition conditions:

- (1) A developer replacement procedure start command was received
- (2) A developer ejection start command was received
- (3) The 30-second ejection operation completed normally
- (4) An error that stopped the developer ejection was detected
- (5) A developer ejection-supply start command was received
- (6) The developer supply operation is completed
- (7) A developer replacement procedure end command was received
- (8) No developer is detected before the automatic toner density adjustment

2-3. Paper Feed Operation

2-3.1. Operational Timing Charts

The paper feed operation can be determined by using the following table and figure references:

- Table 2-1 "VIDEO Signal Control Parameters (Not Depending On Paper Size)," Page 2-8
- Table 2-2 "VIDEO Signal Control Parameters (600 dpi, Depending On Paper Size)," Page 2-9
- Figure 2-6 "Sequence Control of VIDEO Data Timing Diagram," Page 2-10
- Figure 2-8 "Paper Feed Operation Timing Chart," Page 2-17
- Figure 2-9 "Printing Sequence Timing Chart," Page 2-18

- Figure 2-10 "Double-sided Printing Sequence Timing Chart," Page 2-19
- Table 2-3 "Printing Sequence Specifications," Page 2-20
- Figure 2-11 "Prepick Sequence Timing Diagram and Charts," Page 2-21
- Table 2-4 "Jam Codes, Names, Conditions and Messages," Page 2-22
- Figure 2-12 "Position of Jam Detection Sensors," Page 2-24

SERVICE MANUAL

Refer to Figure 2-8 "Paper Feed Operation Timing Chart":

When the power is turned on and when the cover is opened, then shut, or when the error reset command is received:

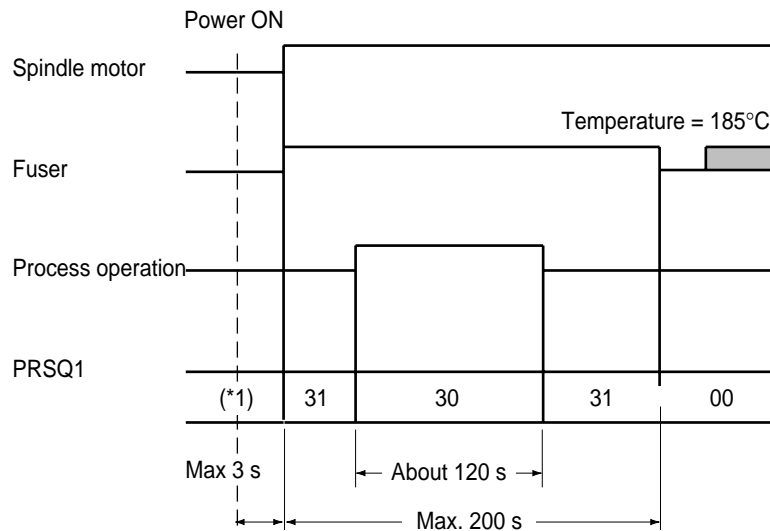

*1 Not defined

Figure 2-8. Paper Feed Operation Timing Chart

Refer to Figure 2-9 "Printing Sequence Timing Chart":

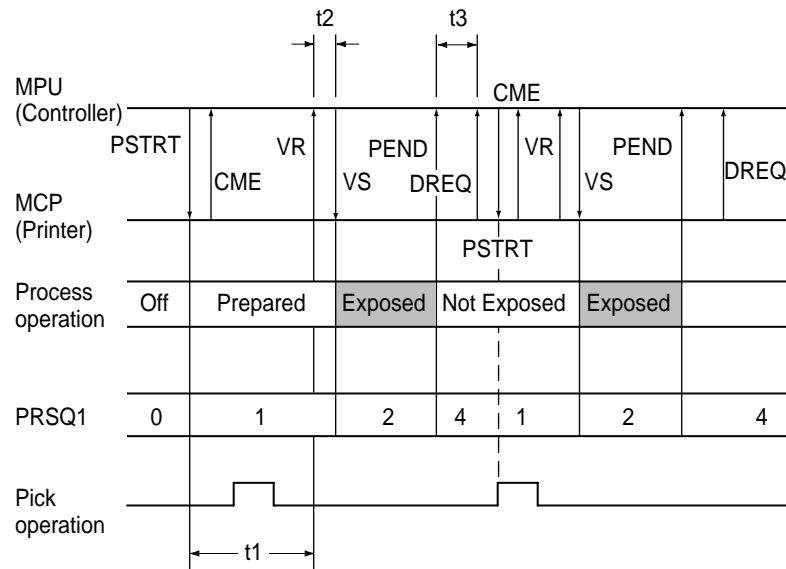

t1	Max. 35 sec
t2	0 to 10 sec (= 0: Maximum processing speed) If t2 exceeds 10 seconds, the VS alarm occurs.
t3	0 to 10 ms 0 ms is normal. (PEND and DREQ are issued simultaneously.)

Figure 2-9. Printing Sequence Timing Chart

SERVICE MANUAL

Refer to Figure 2-10 "Double-sided Printing Sequence Timing Chart":

An example of duplex printing sequence is shown below. Two pages can be contained in the double-sided printing path. Only one page can be contained for the A3 and Ledger portrait size paper.

If one sheet of paper is left in the double-sided printing path, single-sided printing can be performed except A3 and Ledger size paper.

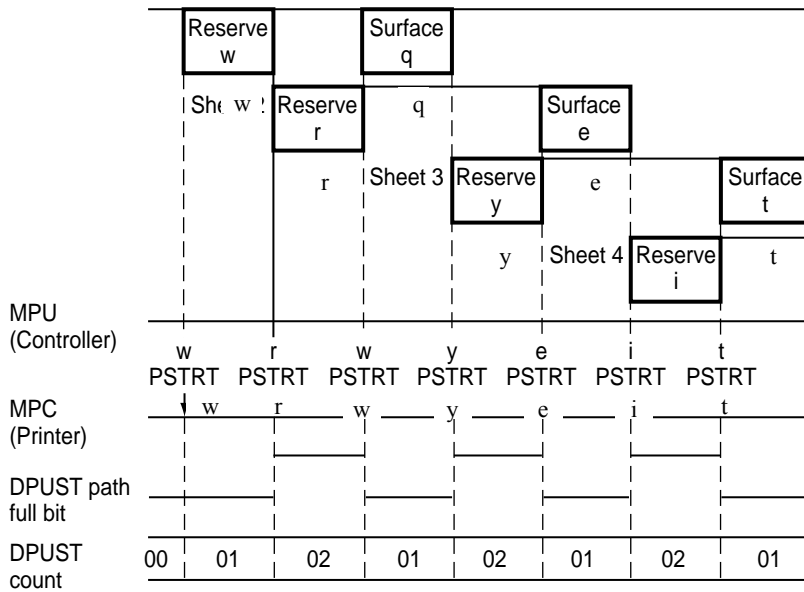

Figure 2-10. Double-sided Printing Sequence Timing Chart

CME, VR, VS, DREQ, and PEND for the PSTRT command are omitted.

The printer issues the double-sided PSTRT command from DREQ or PEND within the time shown below, and assures the maximum printing speed.

- a. Printing sequence ② - ① - ④ - ③
Time from ② to ① for sending one sheet: (To be determined)
- b. Printing sequence ② - ④ - ① - ③
Time from ④ to ① for sending two sheets: See Table 2-3 "Printing Sequence Specifications"
- c. Printing sequence ② - ④ - ① - ⑥ - ③
Time from ⑥ to ③:(See Table 2-3 "Printing Sequence Specifications" **1**
④ to ①:(See Table 2-3 "Printing Sequence Specifications" **2**

Table 2-3. Printing Sequence Specifications

Paper size	Table 1pps	Table 2pps
A5 (V)	825	255
Letter (H)	785	265
A4 (H)	825	255
Legal (V)	130	375

NOTE

For A3 (V) and legal (V) paper, the printing sequence supports single-sheet sending.

SERVICE MANUAL

Refer to Table 2-11 "Prepick Sequence Timing Diagram and Charts":

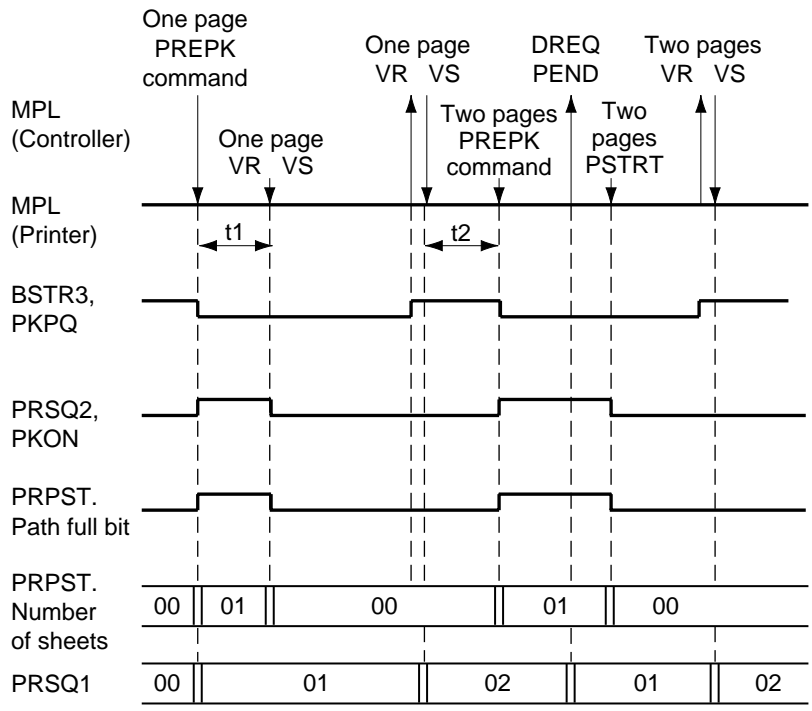

t1	Within 20 seconds If t, exceeds 20 seconds, the PREPK alarm occurs.
t2	If the PREPK command is received within the time shown in the table below, printing speed is at the maximum.

Paper size	t2 (ms)		
	Upper paper tray	Middle paper tray	Lower paper tray
A5 (V)	510	310	110
Letter (H)	550	350	150
A4 (H)	510	310	110
Legal (V)	1320	1120	920
Ledger (V)	1745	1545	1345
A3 (V)	1675	1475	1275

Figure 2-11. Prepick Sequence Timing Diagram and Charts

Refer to Table 2-4 "Jam Codes, Names, Conditions and Messages" and Figure 2-12 "Position of Jam Detection Sensors":

Table 2-4. Jam Codes, Names, Conditions and Messages

Jam Code	Jam Name	Definition	Message
01	Jam 0-1	Paper did not reach sensor PS1-1 from the upper tray before specified time passed after the pick roller started.	Paper tray 1 pick error
02	Jam 0-2	Paper did not reach sensor PS1-2 from the middle tray before specified time passed after the pick roller started.	Paper tray 2 pick error
03	Jam 0-3	Paper did not reach sensor PS1-3 from the lower tray before specified time passed after the pick roller started.	Paper tray 3 pick error
11	Jam 1-1	When the printer is reset, there is paper at PS1-1, or Paper did not reach PS2 before specified time passed after the paper reached PS1-1.	Feed path 1 jam
12	Jam 1-2	When the printer is reset, there is paper at PS1-2, or Paper did not reach PS2 before specified time passed after the paper reached PS1-2.	Feed path 2 jam
13	Jam 1-3	When the printer is reset, there is paper at PS1-3, or Paper did not reach PS3 before specified time passed after the paper reached PS1-3.	Feed path 3 jam
18	Jam 1-8	When the printer is reset, there is paper at PS2, or Paper did not reach PS3 before specified time passed after the paper reached PS2.	Feed path 4 jam
25	Jam 3-1	When the printer is reset, there is paper at PS3. When the regist roller clutch is turned on, there is not paper at PS2. Paper did not reach PS4 before specified time passed after the regist roller clutch is turned on. Paper did not leave PS2 before specified time passed after the regist roller clutch is turned on.	Fusing unit jam 1
26	Jam 3-2	When the printer is reset, there is paper at PS4. The time when paper passed PS4 differs from the standard time specified by paper size printing.	Fusing unit jam 2
29	Jam 4-1	Paper did not reach PS7 before specified time passed after the paper reached PS4.	Ejection unit jam 1
2B	Jam 4-2	When the printer is reset, there is paper at PS6 and PS7. The time when paper passed PS7 differs from the standard time specified by paper size.	Ejection unit jam 2
31	DPU Jam 1	Paper did not reach PS5 before specified time passed after the switch back motor on the duplex unit was rotated.	Duplex path jam 1
32	DPU Jam 2	When the printer is reset, there is paper at PS5. Paper did not reach PS3 before specified time passed after the duplex motor turn on. Paper did not reach PS3 before specified time passed after the paper reached PS5.	Duplex path jam 2

SERVICE MANUAL**Table 2-4. Jam Codes, Names, Conditions and Messages (Cont)**

Jam Code	Jam Name	Definition	Message
41	STK Jam 1	When the printer is reset, there is paper blocking one of the LCS paper sensors. Paper did not reach one of two LCS sensor before specified time passed after the paper reached PS4.	LCS jam 1
51	Jam 1	Paper did not reach KSEN before specified time passed after the pick roller of the LCH started.	LCH jam 1
52	Jam 2	The time when paper passed KSEN differs from the standard time specified by paper size.	LCH jam 2
53	Jam 3	When the printer is reset, there is paper at KSEN.	LCH jam 3

SERVICE MANUAL

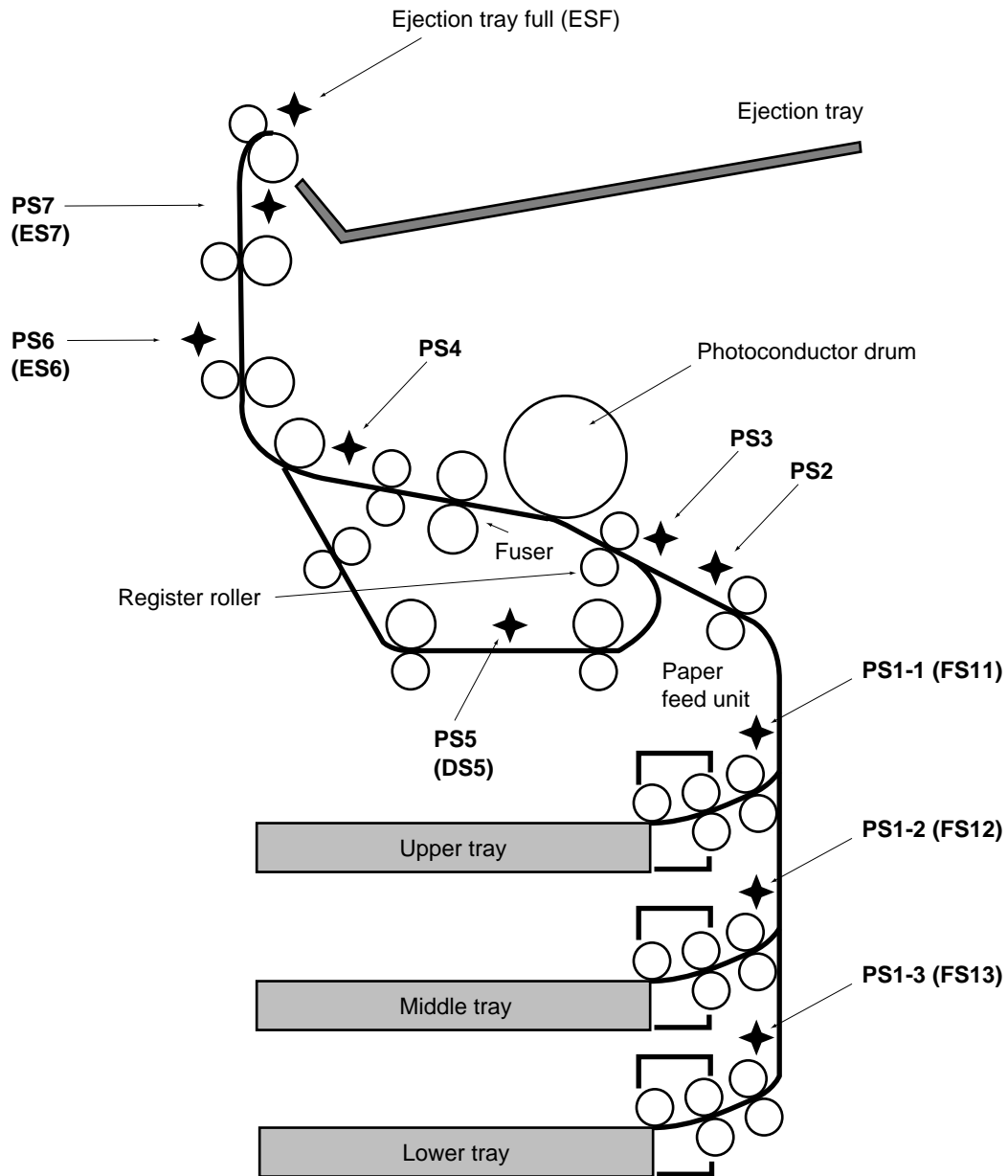

Figure 2-12. Position of Jam Detection Sensors

2-4. Printer Power

Chapter 1 provides the overall printer interconnection block diagram and appendix A provides the detailed printer interconnection wiring diagram. This section provides the functional block diagrams of the low and high power supplies and also the timing chart of the power-on sequence.

2-4.1. Low Voltage Power Supply Block Diagram

Figure 2-13 illustrates the low voltage power supply major functions.

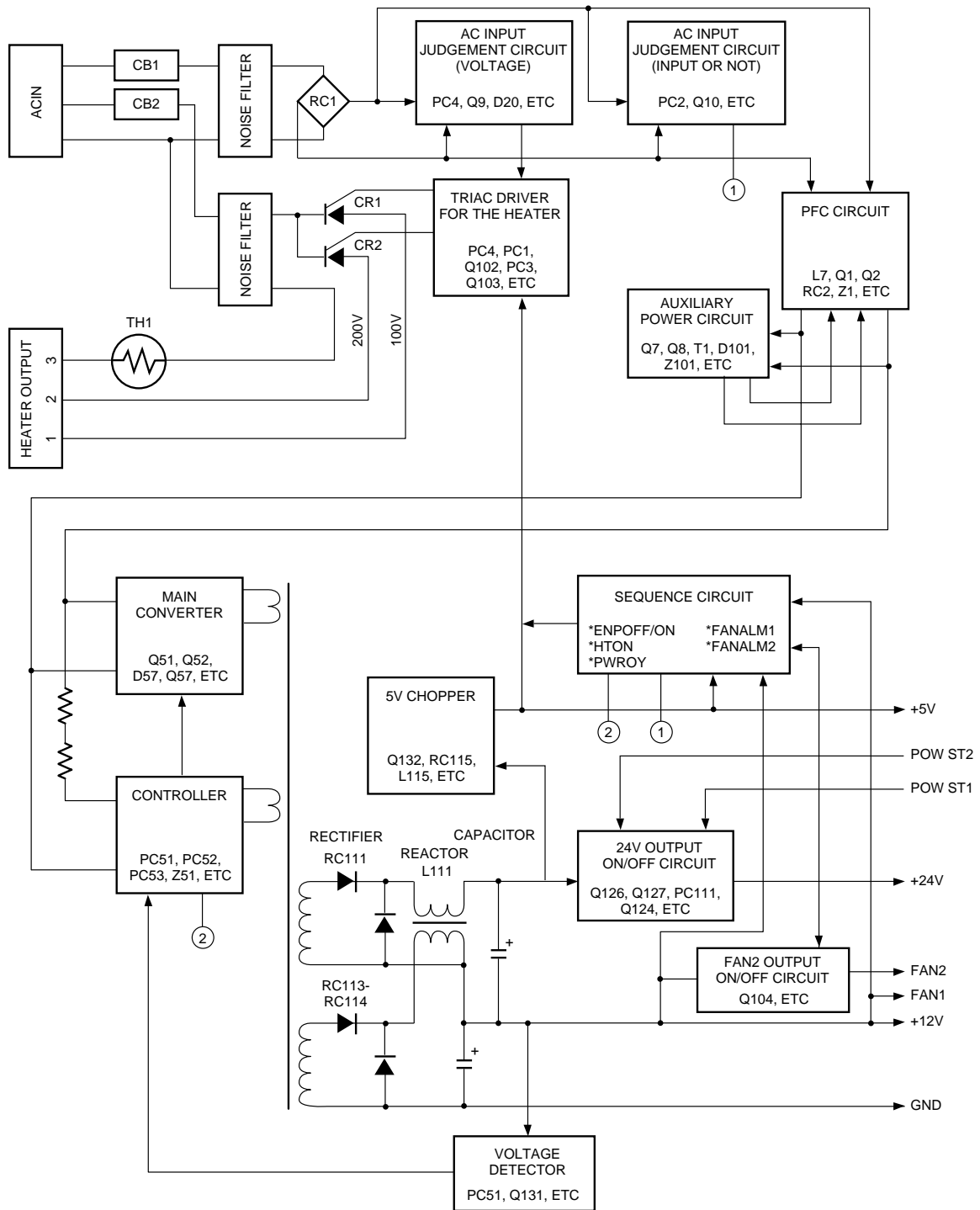

Figure 2-13. LVPS Block Diagram

2-4.2. High Voltage Power Supply Block Diagram

Figure 2-14 through Figure 2-18 illustrate the high voltage power supply major functions.

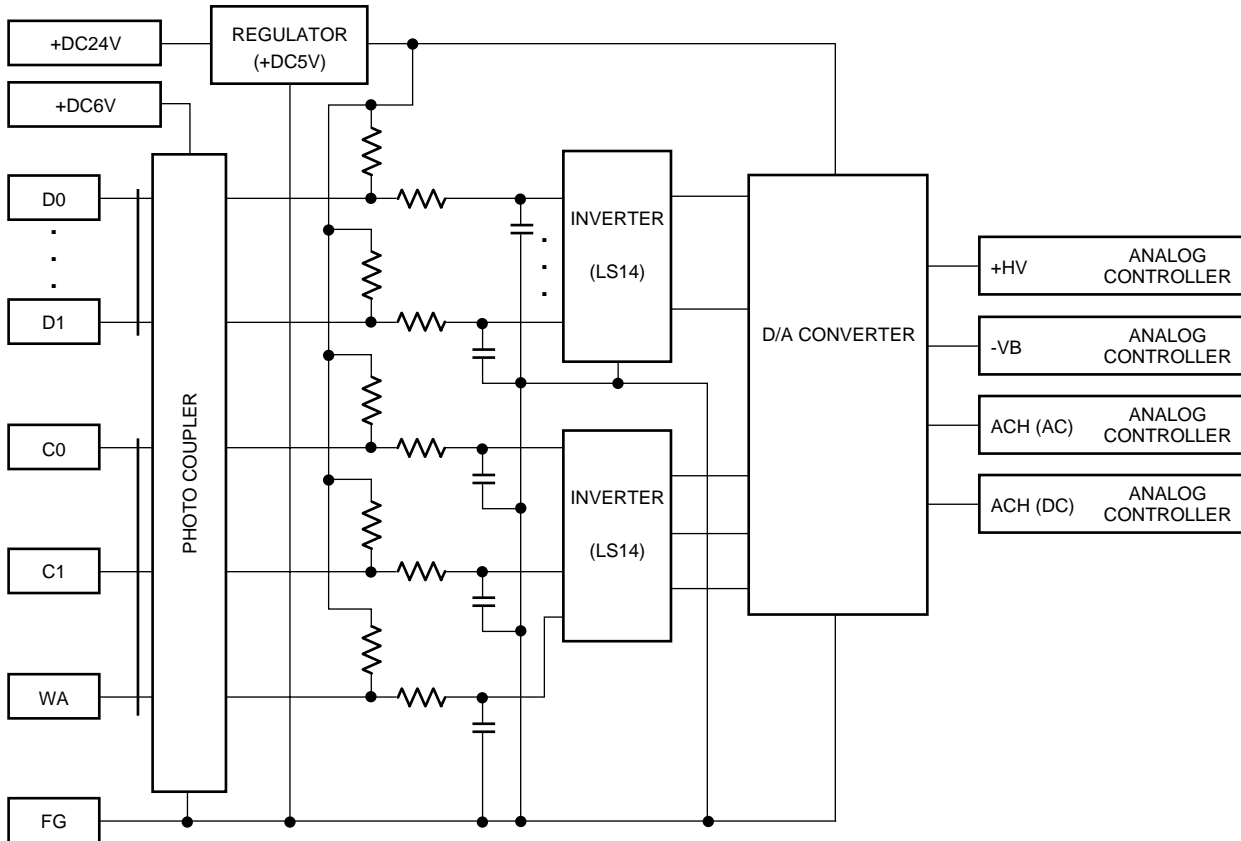

Figure 2-14. HVPS D/A Converter Block Diagram

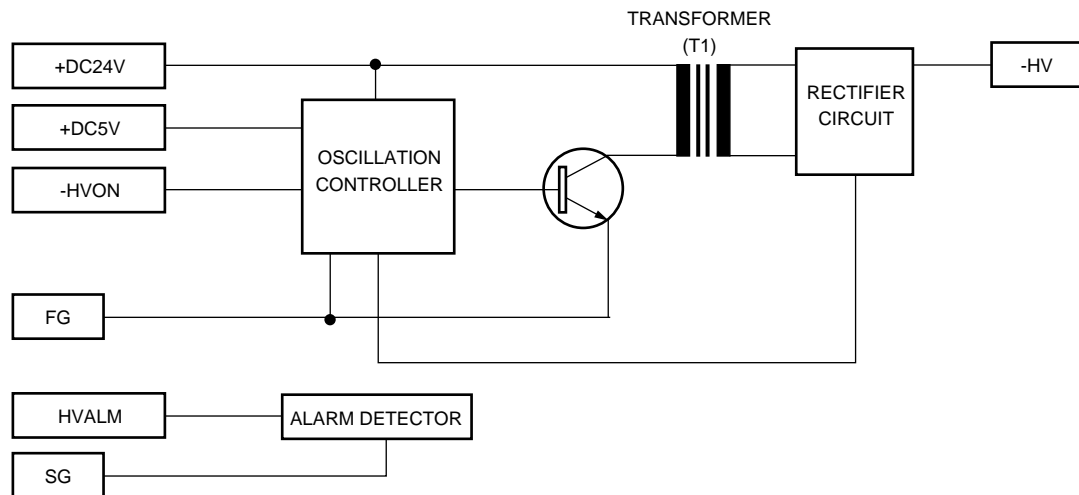

Figure 2-15. HVPS -HV Block Diagram Block Diagram

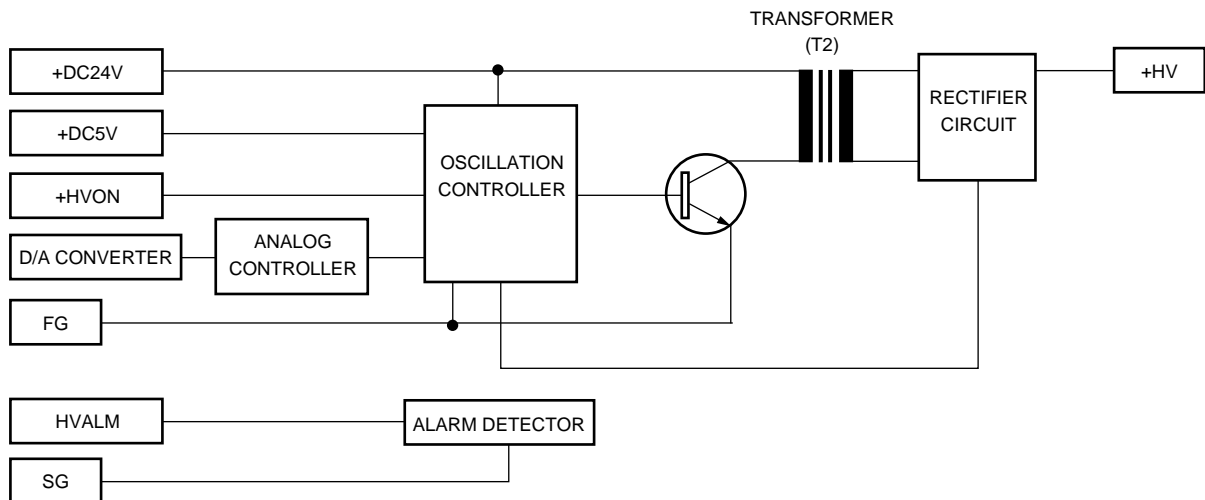

Figure 2-16. HVPS +HV Block Diagram Block Diagram

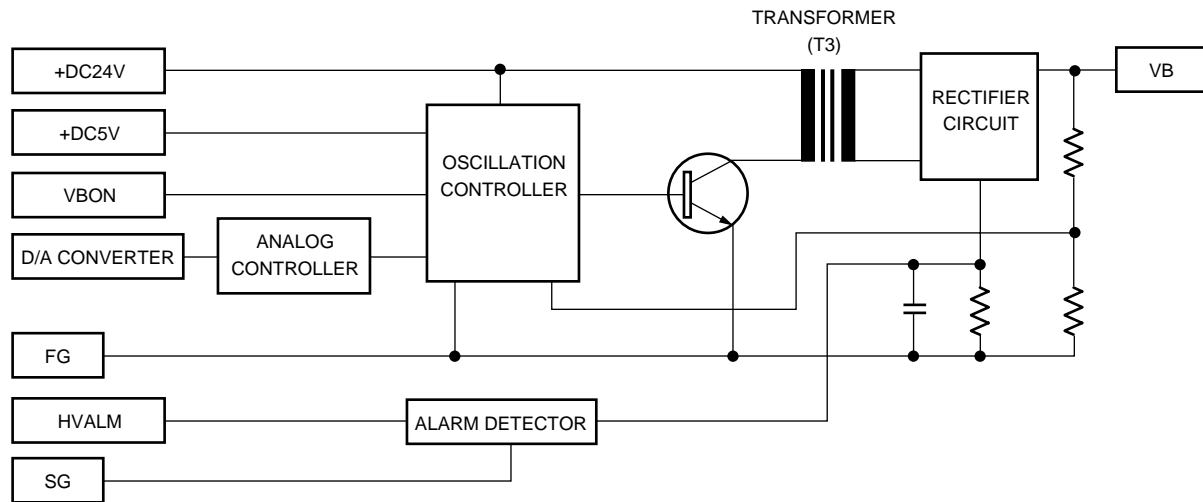

Figure 2-17. HVPS VB Block Diagram

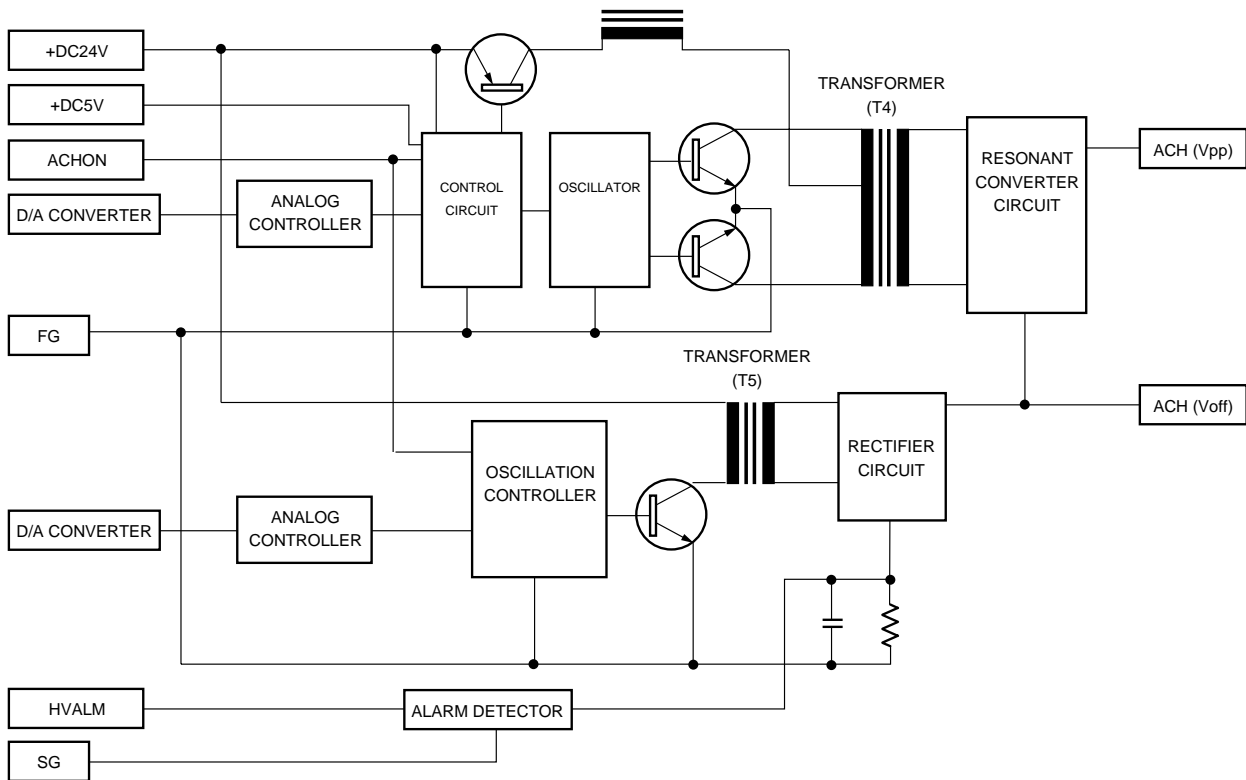

Figure 2-18. HVPS ACH Block Diagram

2-4.3. Power-on Sequence Timing Chart

Figure 2-19 illustrates the printer power-on timing sequence.

"*" means the active-low signal.

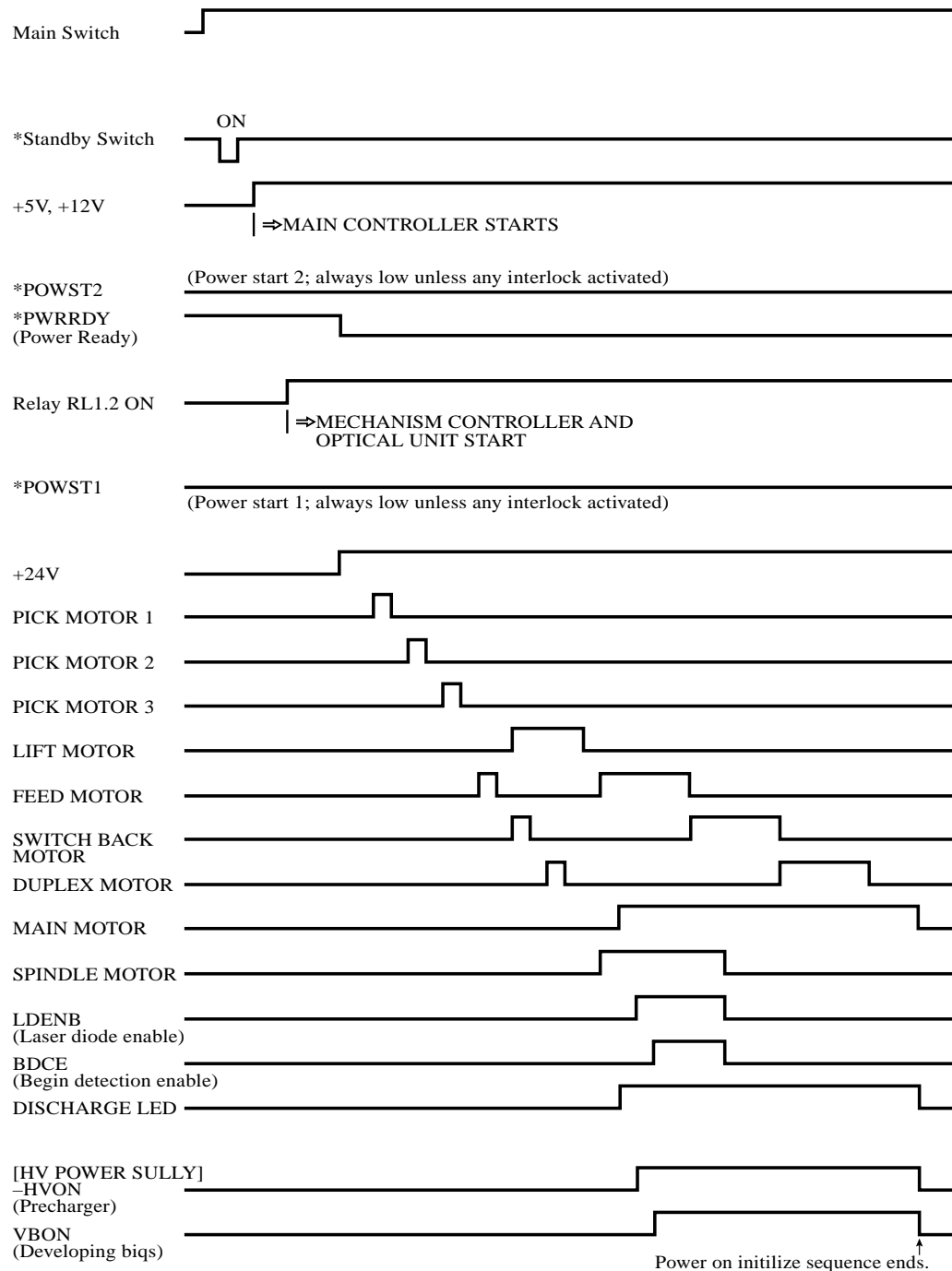

Figure 2-19. Power-on Sequence Timing Chart

SERVICE MANUAL

CHAPTER 3 PRINTER MAINTENANCE PROGRAM

This chapter must be developed for the 4060 printer maintenance program, if installed, driven by the main controller and the software installed.

SERVICE MANUAL

CHAPTER 4 GENERAL TROUBLESHOOTING

Chapter 4 sections include:

Section

4-1	Introduction.....	4-3
4-2	Troubleshooting Overview	4-3
4-3	Error Message and Problem Summaries.....	4-3
4-4	Standard Tools and Test Equipment.....	4-7
4-5	Hints and Tips.....	4-8

4-1. Introduction

This chapter provides a troubleshooting overview, adjustment procedures, a listing of standard tools and test equipment required for printer maintenance, and helpful hints and tips.

4-2. Troubleshooting Overview

Troubleshooting the 4060 printer and the optional Large-Capacity Hopper (LCH) begins by recognizing a fault condition whether reported by the machines or by observation. This chapter provides one location for summaries of information found elsewhere in this manual and also provides reference diagrams and procedures that may be referenced by many troubleshooting flow charts.

4-3. Error Message and Problem Summaries

Error messages are displayed on the operator panel. The messages are explained in detail in chapter 5. The message codes are the starting points for troubleshooting flow charts. The failure codes and messages are:

- Printer component sensors Table 4-1 "Sensor Codes and Messages"
- Paper jam sensors Table 4-2 "Jam Codes and Messages"

Table 4-1. Sensor Codes and Messages

Displayed Code	Code Meaning or Problem Description
SVC08	Upper Pick Motor Alarm
SVC09	Middle Pick Motor Alarm
SVC0A	Lower Pick Motor Alarm
SVC0B	Reversing Motor Alarm
SVC0D	Feed Motor Alarm
SVC0E	Stacker Select Solenoid Alarm
SVC0F	Duplex Motor Alarm
SVC27	Fuser Alarm (Time-out)
SVC28	Fuser High-temperature Alarm
SVC29	Fuser Low-temperature Alarm
SVC50	Toner Motor Alarm
SVC51	Toner Discharge Screw Alarm
SVC52	Developer Discharge Alarm
SVC54	Developer Discharge Shutter Alarm
SVC56	Automatic Adjustment Alarm
SVC57	Toner High-density Alarm
SVC58	Toner Low Density Alarm
SVC59	Reference Voltage Alarm (Too High)
SVC5A	Reference Voltage Alarm (Too Low)
SVC5B	Toner Hopper Alarm
SVC69	Main Motor Alarm
SVC6F	High Voltage Power Alarm
SVC79	Spindle Motor Alarm
SVC7A	BD1 (Beam Detection) Alarm
SVC7B	BD2 (Beam Detection) Alarm
SVC7C	Beam Detection High-speed Alarm
SVC7D	Beam Detection Low-speed Alarm
SVC7E	Laser Diode (LD) Alarm

SERVICE MANUAL**Table 4-1. Sensor Codes and Messages (Cont)**

Displayed Code	Code Meaning or Problem Description
SVCA0	Fan Alarm 1
SVCA1	Fan Alarm 2
SVCA5	Fan Alarm 6
SVCA6	Fan Alarm 7
SVCB0	Watchdog Timer Alarm - Master)
SVCB1	Watchdog Timer Alarm - Slave)
SVCB3	Communication Alarm (For Mechanism Controller)
SVCB4	EEPROM Alarm
SVCB5	Video Synchronous (VS) Alarm
SVCB6	Pre-pick Alarm
SVCB7	Video Request (VR) Alarm
SVCC4	LCH Elevator Descent Alarm
SVCC5	LCH Elevator Ascent Alarm
SVCD8	LCS Stacker Alarm

Table 4-2. Jam Codes and Messages

Jam Code	Jam Name	Definition	Message
01	Jam 0-1	Paper did not reach sensor PS1-1 from the upper tray before specified time passed after the pick roller started.	Paper tray 1 pick error
02	Jam 0-2	Paper did not reach sensor PS1-2 from the middle tray before specified time passed after the pick roller started.	Paper tray 2 pick error
03	Jam 0-3	Paper did not reach sensor PS1-3 from the lower tray before specified time passed after the pick roller started.	Paper tray 3 pick error
11	Jam1-1	When the printer is reset, there is paper at PS1-1, or Paper did not reach PS2 before specified time passed after the paper reached PS1-1.	Feed path 1 jam
12	Jam 1-2	When the printer is reset, there is paper at PS1-2, or Paper did not reach PS2 before specified time passed after the paper reached PS1-2.	Feed path 2 jam
13	Jam 1-3	When the printer is reset, there is paper at PS1-3, or Paper did not reach PS2 before specified time passed after the paper reached PS1-3.	Feed path 3 jam

Table 4-2. Jam Codes and Messages (Cont)

Jam Code	Jam Name	Definition	Message
18	Jam 1-8	When the printer is reset, there is paper at PS2, or Paper did not reach PS3 before specified time passed after the paper reached PS2.	Feed path 4 jam
25	Jam 3-1	When the printer is reset, there is paper at PS3. When the regist roller clutch is turned on, there is not paper at PS2. Paper did not reach PS4 before specified time passed after the regist roller clutch is turned on. Paper did not leave PS2 before specified time passed after the regist roller clutch is turned on.	Fusing unit jam 1
26	Jam 3-2	When the printer is reset, there is paper at PS4. The time when paper passed PS4 differs from the standard time specified by paper size printing.	Fusing unit jam 2
29	Jam 4-1	Paper did not reach PS7 before specified time passed after the paper reached PS4.	Ejection unit jam 1
2B	Jam 4-2	When the printer is reset, there is paper at PS6 and PS7. The time when paper passed PS7 differs from the standard time specified by paper size.	Ejection unit jam 2
31	DPU Jam 1	Paper did not reach PS5 before specified time passed after the switch back motor on the duplex unit was rotated.	Duplex path jam 1
32	DPU Jam 2	When the printer is reset, there is paper at PS5. Paper did not reach PS3 before specified time passed after the duplex motor turn on. Paper did not reach PS3 before specified time passed after the paper reached PS5.	Duplex path jam 2
41	STK Jam 1	When the printer is reset, there is paper blocking one of the LCS paper sensors. Paper did not reach one of two LCS sensor before specified time passed after the paper reached PS4.	LCS jam 1
51	Jam 1	Paper did not reach KSEN before specified time passed after the pick roller of the LCH started.	LCH jam 1
52	Jam 2	The time when paper passed KSEN differs from the standard time specified by paper size.	LCH jam 2
53	Jam 3	When the printer is reset, there is paper at KSEN.	LCH jam 3

4-4. Standard Tools and Test Equipment

The following are required standard tools and test equipment for effective printer maintenance:

- Toner vacuum cleaner with 5 micron filtering (or better) for cleaning spilled toner.
- Cleaning sheets for wiping spilled toner.
- Multimeter for testing voltages and continuity.
- 2 mm Allen wrench for registration clutch maintenance.
- Phillips #2 head, magnetized, screwdriver set:
 - 2-inch for LED unit maintenance
 - 8-inch for general maintenance

SERVICE MANUAL

- 12-inch for toner hopper hose maintenance
- Flat head screwdriver (long):
 - 1/8-inch blade to adjust LVPS +5V output
 - 1/4-inch blade for general maintenance
- Small metric-scaled ruler to measure paper registration
- Isopropyl alcohol for cleaning optics lens and other surfaces.
- Electrostatic discharge (ESD):
 - Wrist strap for handling ESD sensitive components
 - Pad to lay ESD sensitive components upon
- Cable ties to resecure harnesses cut for maintenance.

4-5. Hints and Tips

NOTE

To service providers, send your hints and tips to headquarters by way of the READER COMMENT SHEET (found at the end of this manual) for sharing with others.

The following hints and tips provide the service personnel some insight to printer design and effective service techniques:

- (1) **Red painted screw heads** - Do **not** attempt to loosen or remove these screws. They are factory set for optimum performance of the printer.
- (2) **Green painted screw heads** - These screws are used for setting belt tension.
- (3) **+5V power adjustment** - The actual LVPS output value is +4.82 +/-0.02V.
- (4) **Printer fan locations** - Figure 4-1 identifies printer fan locations and their respective voltages.

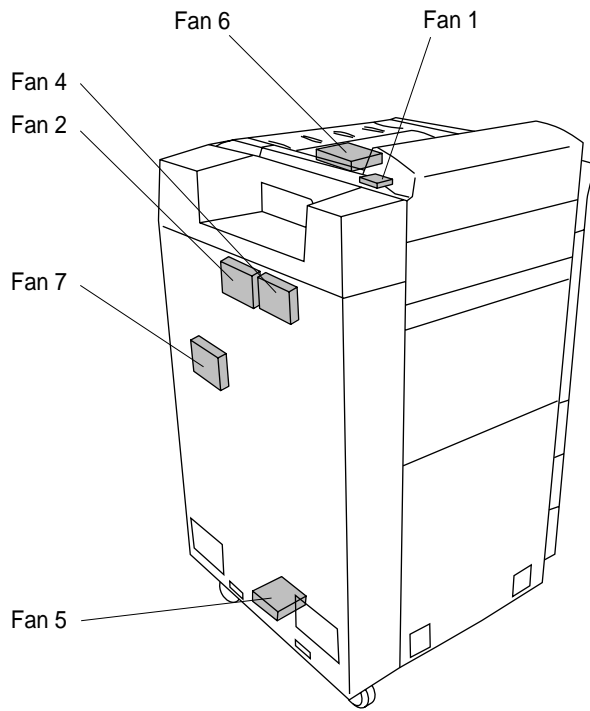

Notes:

1. All 24V fans stop when any interlock switch is opened.
2. All 12V fans continue running regardless if any interlock switch is opened.
3. Fan assignments are:

Fan	Voltage	Purpose
1	24V	Cool optical unit
2	24V	Cool main frame
4	12V	Cool fuser
5	12V	Cool LVPS
6	24V	Cool main controller board
7	24V	C Cool main frame

Figure 4-1. Printer Fan Locations and Fan Voltages

SERVICE MANUAL

- (5) **Movable-bracket positioning-pins and locating-holes** - Figure 4-2 illustrates proper reinstallation of critical hardware. A bracket misaligned due to careless remounting can cause expensive damage.

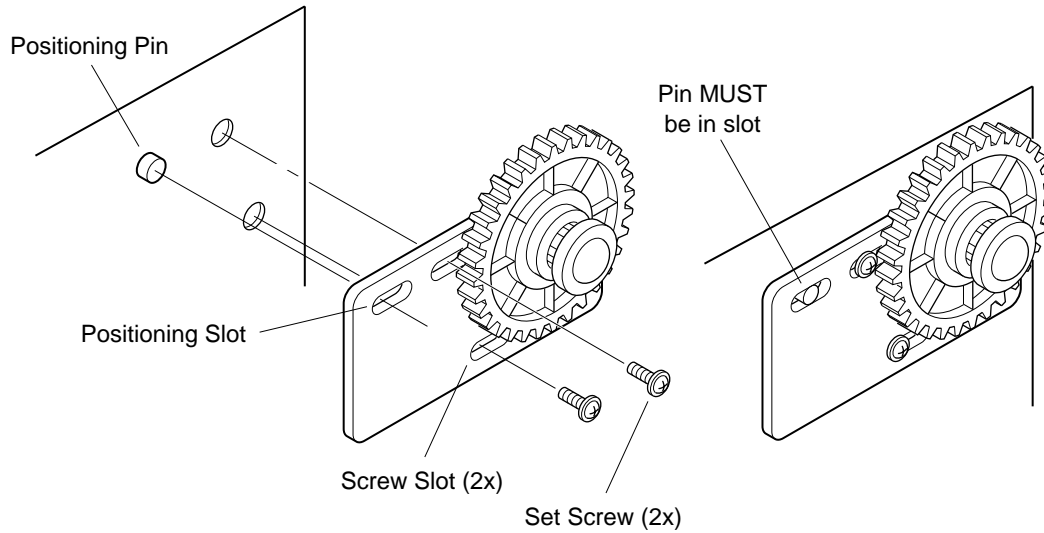

Figure 4-2. Example of Positioning-Pins and Holes On Bracket Assemblies

CHAPTER 5 TROUBLESHOOTING

Chapter 5 contents include:

Section

5-1.	Troubleshooting Approach	5-15
5-1.1.	General Troubleshooting Flow Chart	5-17
5-2.	Alarm Error Message Reported Problems	5-19
5-2.1.	SVC08 Upper Pick Motor Alarm	5-20
5-2.2.	SVC09 Middle Pick Motor Alarm	5-22
5-2.3.	SVC0A Lower Pick Motor Alarm	5-24
5-2.4.	SVC0B Reversing Motor Alarm	5-26
5-2.5.	SVC0D Feed Motor Alarm	5-28
5-2.6.	SVC0E Stacker Select Solenoid Alarm	5-30
5-2.7.	SVC0F Duplex Motor Alarm	5-32
5-2.8.	SVC27 Fuser Time-out Alarm	5-34
5-2.9.	SVC28 Fuser High-temperature Alarm	5-39
5-2.10.	SVC29 Fuser Low-temperature Alarm	5-43
5-2.11.	SVC50 Toner Motor Alarm	5-48
5-2.12.	SVC51 Toner Discharge Screw Alarm	5-49
5-2.13.	SVC52 Developer Discharge Alarm	5-52
5-2.14.	SVC54 Developer Discharge Shutter Alarm	5-58
5-2.15.	SVC56 Automatic Adjustment Alarm	5-63
5-2.16.	SVC57 Toner High-density Alarm	5-69
5-2.17.	SVC58 Toner Low-density Alarm	5-74
5-2.18.	SVC59 Reference Voltage Too-High Alarm	5-78
5-2.19.	SVC5A Reference Voltage Too-Low Alarm	5-83
5-2.20.	SVC5B Toner Hopper Alarm	5-86
5-2.21.	SVC69 Main Motor Alarm	5-89
5-2.22.	SVC6F High Voltage Power Alarm	5-95
5-2.23.	SVC79 Spindle Motor Alarm	5-102
5-2.24.	SVC7A BD1 (Beam Detection) Alarm	5-107
5-2.25.	SVC7B BD2 (Beam Detection) Alarm	5-111
5-2.26.	SVC7C Beam Detection High-speed Alarm	5-115
5-2.27.	SVC7D Beam Detection Low-speed Alarm	5-119
5-2.28.	SVC7E Laser Diode (LD) Alarm	5-123
5-2.29.	SVCA0 Fan Alarm 1	5-127
5-2.30.	SVCA1 Fan Alarm 2	5-131
5-2.31.	SVCA5 Fan Alarm 6	5-137
5-2.32.	SVCA6 Fan Alarm 7	5-143
5-2.33.	SVCB0 Watchdog Timer Alarm—Master	5-148

SERVICE MANUAL

5-2.34.	SVCB1	Watchdog Timer Alarm—Slave	5-150
5-2.35.	SVCB3	Mechanism Controller Communication Alarm	5-152
5-2.36.	SVCB4	EEPROM Alarm	5-154
5-2.37.	SVCB5	Video Synchronous (VS) Alarm	5-156
5-2.38.	SVCB6	Pre-pick Alarm	5-158
5-2.39.	SVCB7	Video Request (VR) Alarm	5-160

5-3.	Paper Jam Error Message Reported Problems	5-163
5-3.1.	JAM01/02/03 Pick Error	5-164
5-3.2.	JAM11/12/13 Feed Jam 1	5-172
5-3.3.	JAM18 Feed Jam 2	5-178
5-3.4.	JAM25 Fuser Unit Jam 1	5-182
5-3.5.	JAM26/27 Fuser Unit Jam 2	5-196
5-3.6.	JAM29 Ejection Unit Jam 1	5-202
5-3.7.	JAM2B/2C Ejection Unit Jam 2	5-210
5-3.8.	JAM31 Duplex Printing Path Jam 1	5-218
5-3.9.	JAM32 Duplex Printing Path Jam 2	5-226
5-4.	Power Related Problems	5-235
5-4.1.	Cannot Power Printer Mechanism or Controls ON	5-236
5-4.2.	Control Powers ON But Cannot Power Printer Mechanism ON	5-244
5-4.3.	Cannot Power Off Printer With Stand-by Switch	5-254
5-5.	Miscellaneous Problems	5-259
5-5.1.	Operator Panel Symptoms	5-260
5-5.2.	Cover Open / Interlock	5-262
5-5.3.	Paper Tray Not Ready	5-268
5-5.4.	Out of Paper	5-270
5-5.5.	Stacker Full Cannot Be Cleared	5-274
5-5.6.	Stacker Full Cannot Be Detected	5-278
5-5.7.	Developer Cannot Discharge Unless START Pressed	5-280
5-6.	Print Quality Problems	5-285
5-6.1.	General Approach to Print Quality Problems	5-286
5-6.2.	Good Quality Print	5-287
5-6.3.	Black or Dark Print	5-291
5-6.4.	Blank Print	5-293
5-6.5.	Blank Vertical Bands Print	5-297
5-6.6.	Blurred Images or Blurred Characters Print	5-301
5-6.7.	Dark-specks, Dark-lines, or Dark-areas Print	5-305
5-6.8.	Dark Vertical Lines Print	5-308
5-6.9.	Fusing Problems Print	5-310
5-6.10.	Light Print With Background	5-312
5-6.11.	Light Horizontal Bands Print	5-318
5-6.12.	Light Vertical Streaks Print	5-320
5-6.13.	Misregistration Print	5-324
5-6.14.	Residual Images Print	5-326
5-6.15.	Skewed Print	5-330
5-6.16.	Varying Print Density Print	5-332
5-6.17.	Washed-out Print	5-336
5-7.	LCH Alarm Error Message Reported Problems	5-341

SERVICE MANUAL

5-7.1.	JAM51	LCH Pick Error	5-342
5-7.2.	JAM52	LCH Feed Jam 1	5-354
5-7.3.	JAM53	LCH Feed Jam 2	5-364
5-7.4.	SVCC4	LCH Elevator Descent Alarm	5-368
5-7.5.	SVCC5	LCH Elevator Ascent Alarm	5-372
5-8.		LCH Miscellaneous Problems	5-376
5-8.1.		LCH Sensing Problem 1	5-376
5-8.2.		LCH Sensing Problem 2	5-379
5-9.		LCS Alarm Error Message Reported Problems	5-383
5-9.1.	JAM41	LCS Stacker Jam	5-386
5-9.2.	SVCD8	LCS Stacker Alarm	5-396
5-10.		LCS Miscellaneous Problems	5-407
5-10.1.		LCS Stacker Full Related Problems	5-407
5-10.2.		LCS Door Open Related Problems	5-416
5-10.3.		LCS Stacker Tray Continuous Up-Down Travel	5-419
5-10.4.		LCS Stacker Tray Stays Down	5-422
5-10.5.		LCS Not Sensed By Printer	5-424
5-10.6.		LCS Not Installed But Sensed By Printer	5-426

5-1. Troubleshooting Approach

The general troubleshooting flow chart provides a basic approach to troubleshooting 4060 Printer problems. Always proceed sequentially, throughout the flow and never assume the printer is functioning correctly without fully investigating the flow. **If the problem still occurs when you reach the end of the flow, please contact your specialist with detailed information about the problem and what you have done for it.**

5-1.1. General Troubleshooting Flow Chart

Explanation

Use this flow chart to begin the 4060 Printer fault isolation and repair.

Troubleshooting Procedure

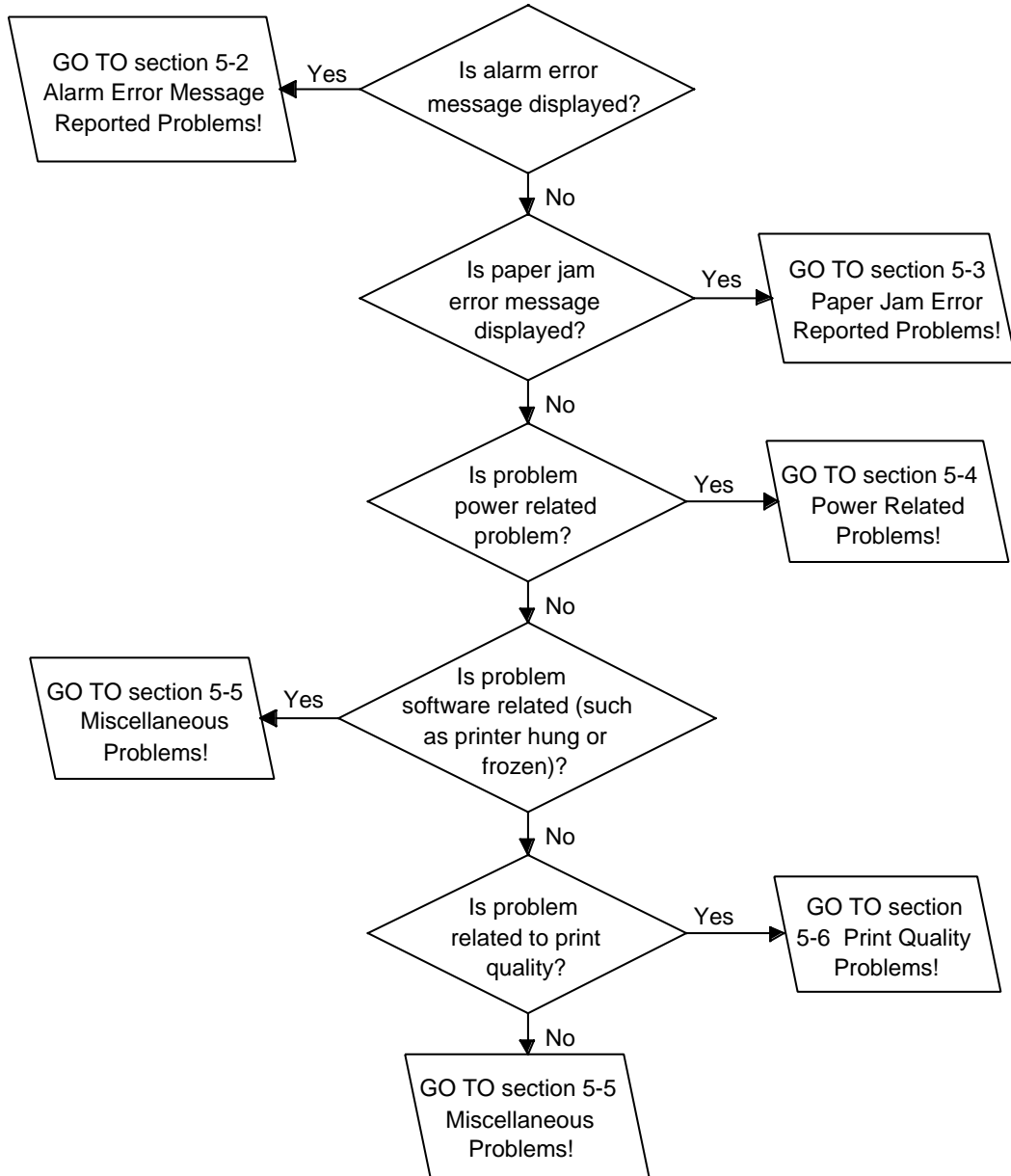

Figure 5-1. General Troubleshooting Flow Chart

5-2. Alarm Error Message Reported Problems

5-2.1. SVC08 Upper Pick Motor Alarm

Explanation

An overcurrent of the upper paper supply tray pick (stepper) motor was detected by the mechanism controller. Note that if any roller or shaft is locked or clogged, an overcurrent condition has not occurred.

Troubleshooting Procedure

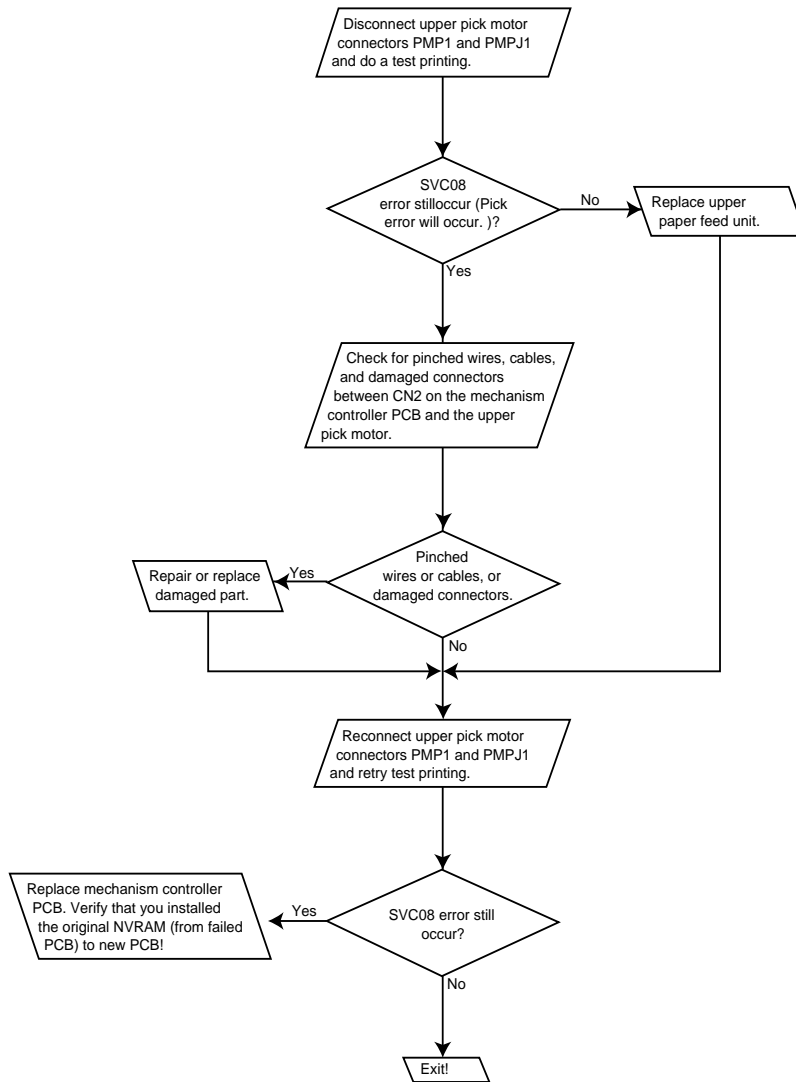

Figure 5-2. SVC08 Upper Pick Motor Alarm Flow Chart

Reference Diagrams

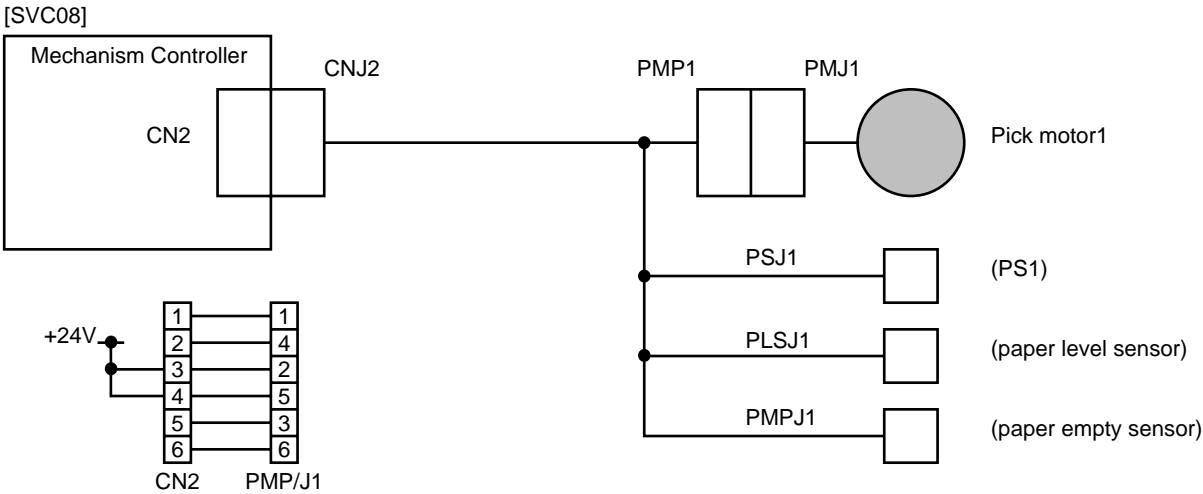

Figure 5-3. Upper Pick Motor Alarm (SVC08) Interconnections Diagram

5-2.2. SVC09 Middle Pick Motor Alarm

Explanation

An overcurrent of the middle paper supply tray pick (stepper) motor was detected by the mechanism controller. Note that if any roller or shaft is locked or clogged, an overcurrent condition has not occurred.

Troubleshooting Procedure

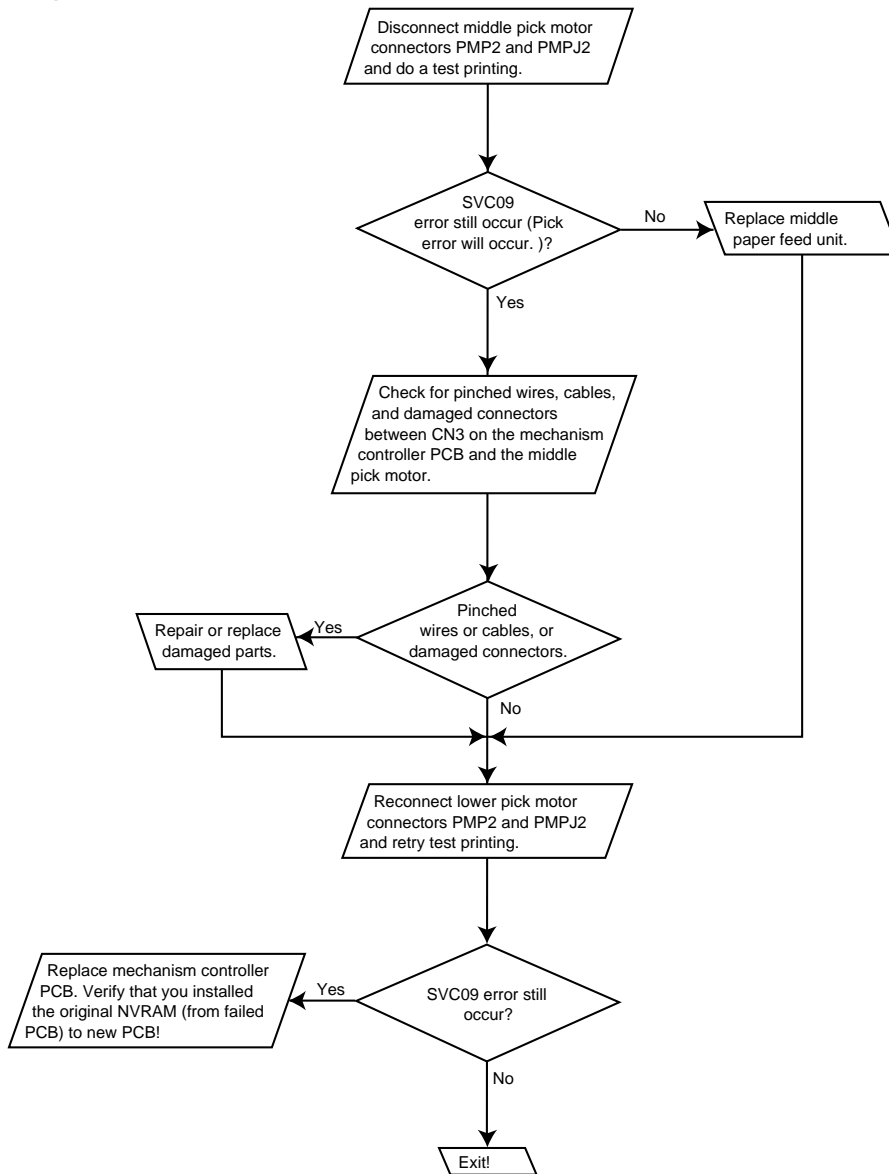

Figure 5-4. SVC09 Middle Pick Motor Alarm Flow Chart

Reference Diagrams

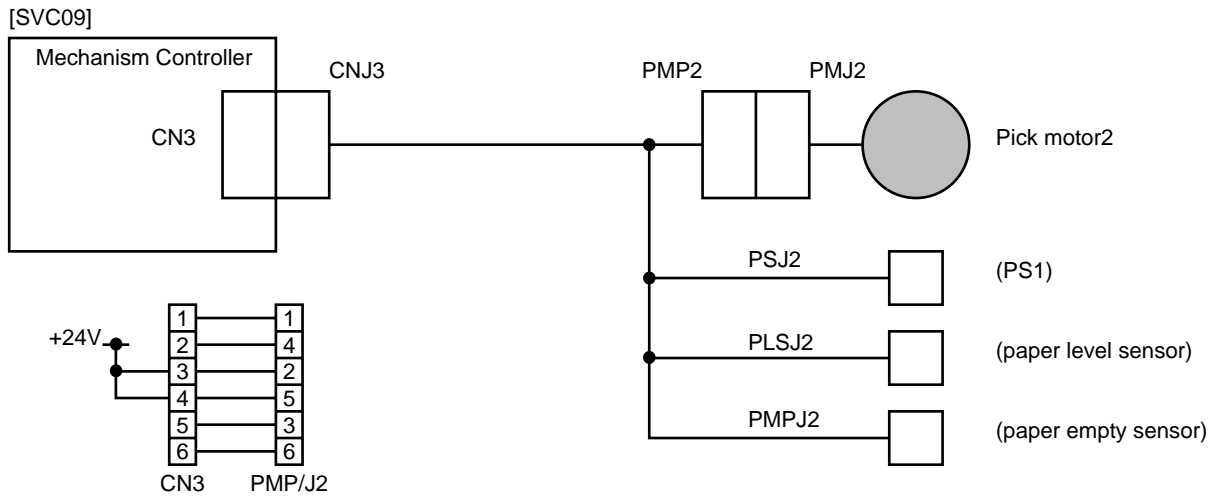

Figure 5-5. Middle Pick Motor Alarm (SVC09) Interconnections Diagram

5-2.3. SVC0A Lower Pick Motor Alarm

Explanation

An overcurrent of the lower paper supply tray pick (stepper) motor was detected by the mechanism controller. Note that if any roller or shaft is locked or clogged, an overcurrent condition has not occurred.

Troubleshooting Procedure

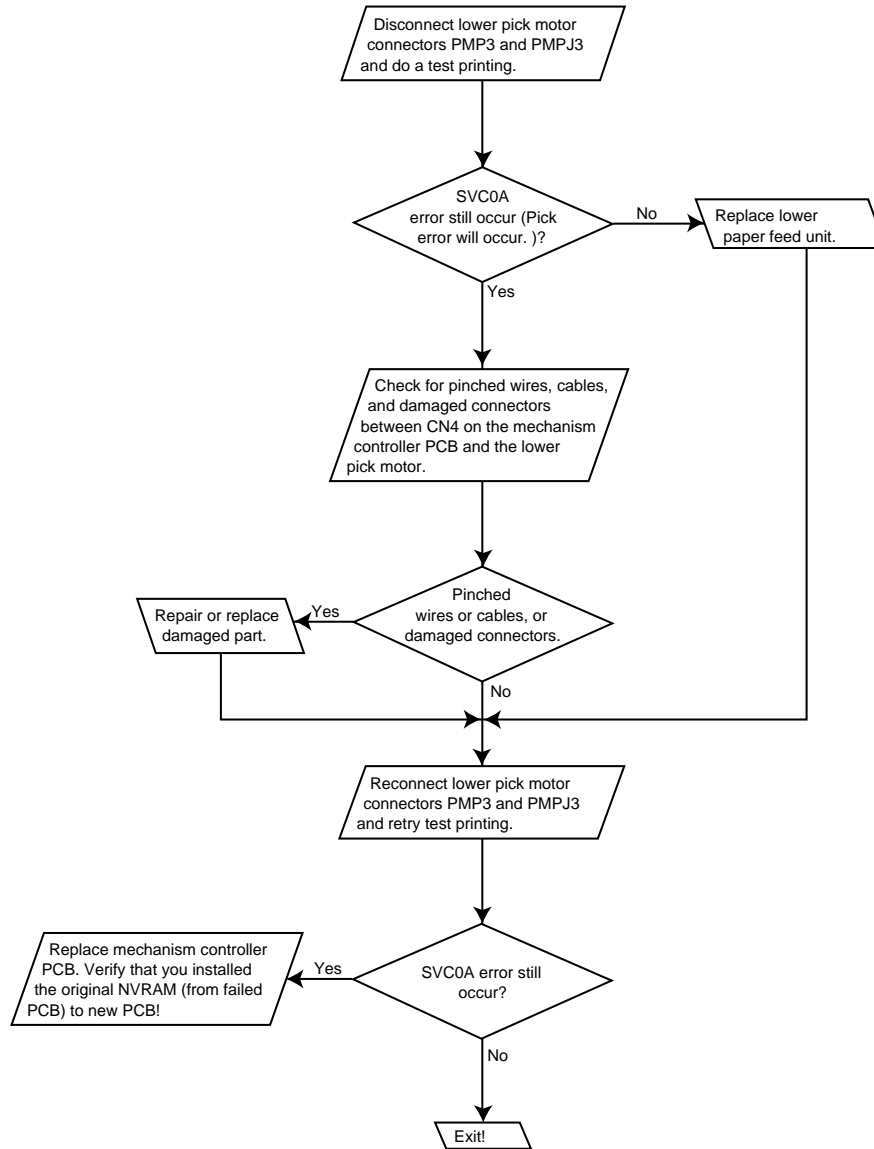

Figure 5-6. SVC0A Lower Pick Motor Alarm Flow Chart

Reference Diagrams

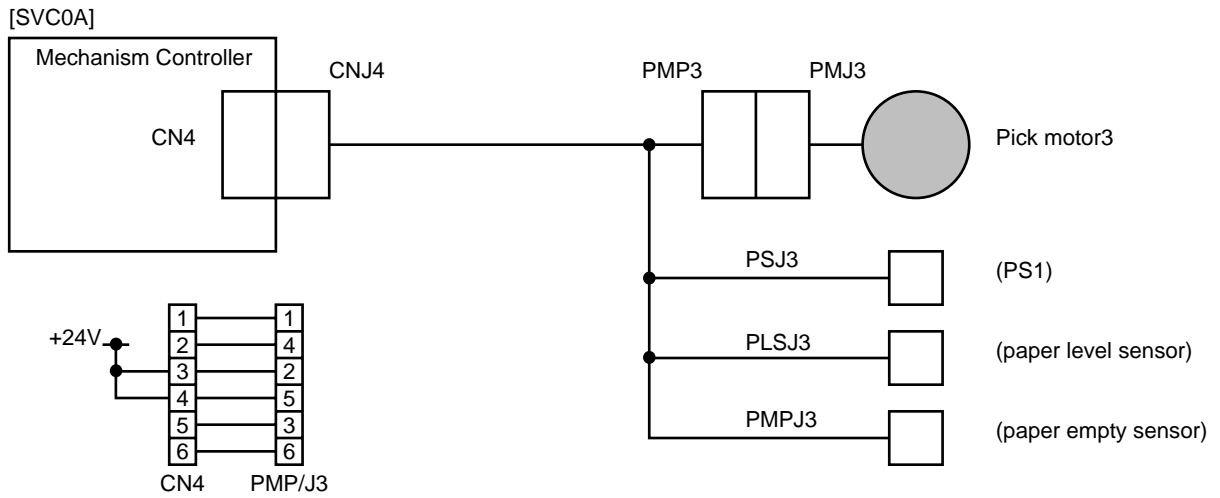

Figure 5-7. Lower Pick Motor Alarm (SVC0A) Interconnections Diagram

5-2.4. SVC0B Reversing Motor Alarm

Explanation

An overcurrent of the reversing motor (stepper motor) of the reversing unit was detected in the mechanism controller. Note that if any roller or shaft is locked or clogged, the overcurrent is not occurred.

Troubleshooting Procedure

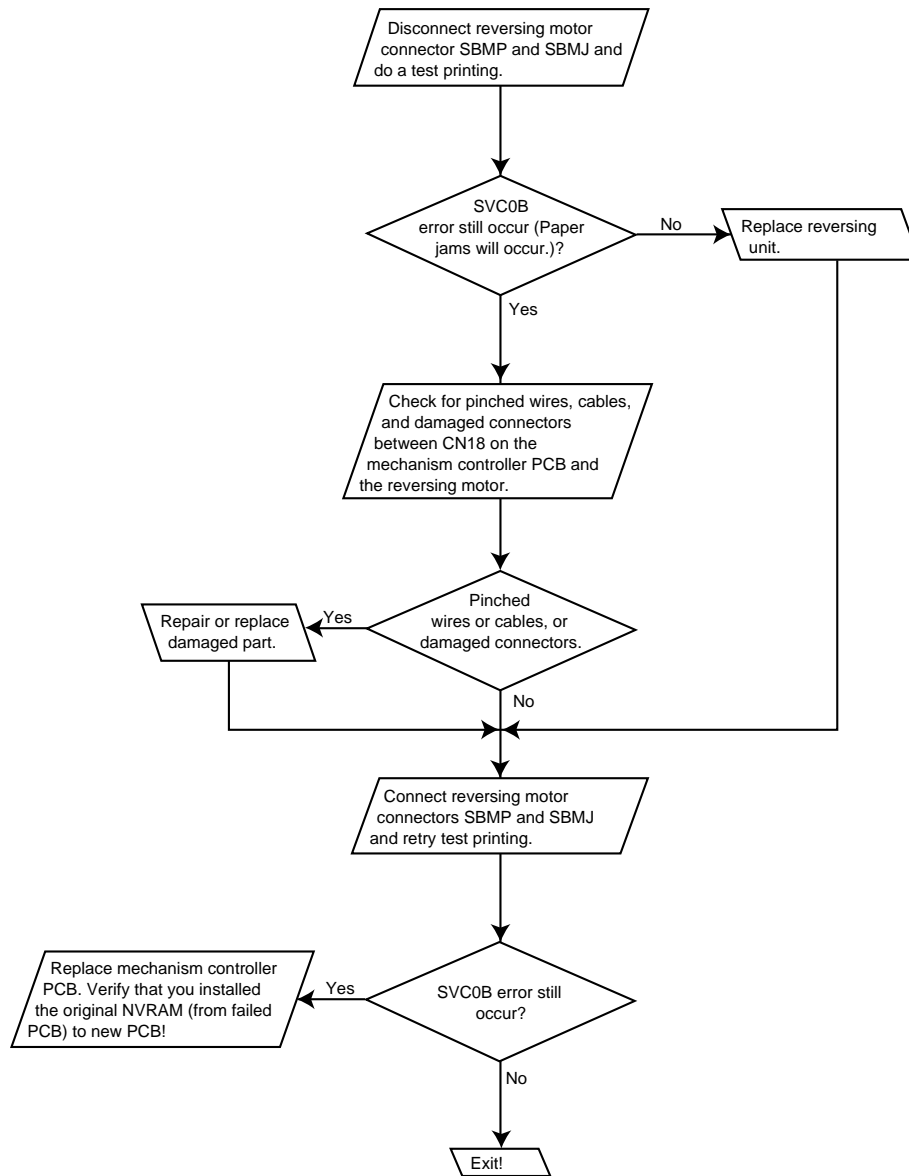

Figure 5-8. SVC0B Reversing Motor Alarm Flow Chart

Reference Diagrams

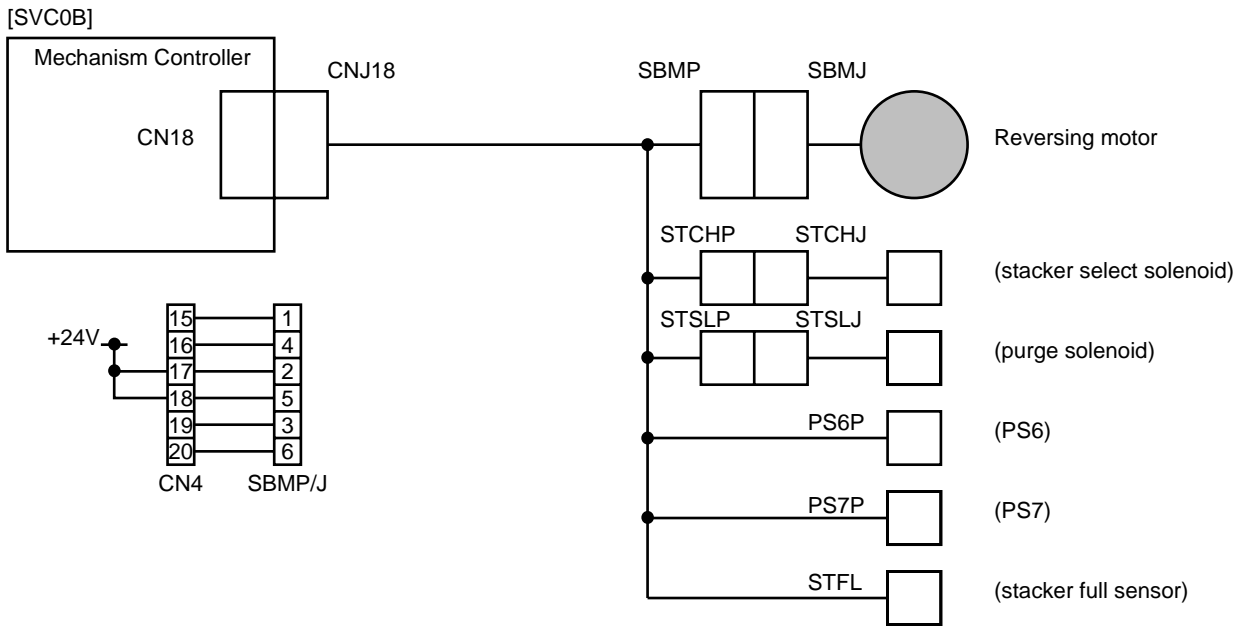

Figure 5-9. Reversing Motor Alarm (SVC0B) Interconnections Diagram

5-2.5. SVC0D Feed Motor Alarm

Explanation

An overcurrent of the feed motor (stepper motor) of the transport assembly was detected in the mechanism controller. Note that if any roller or shaft is locked or clogged, the overcurrent is not occurred.

Troubleshooting Procedure

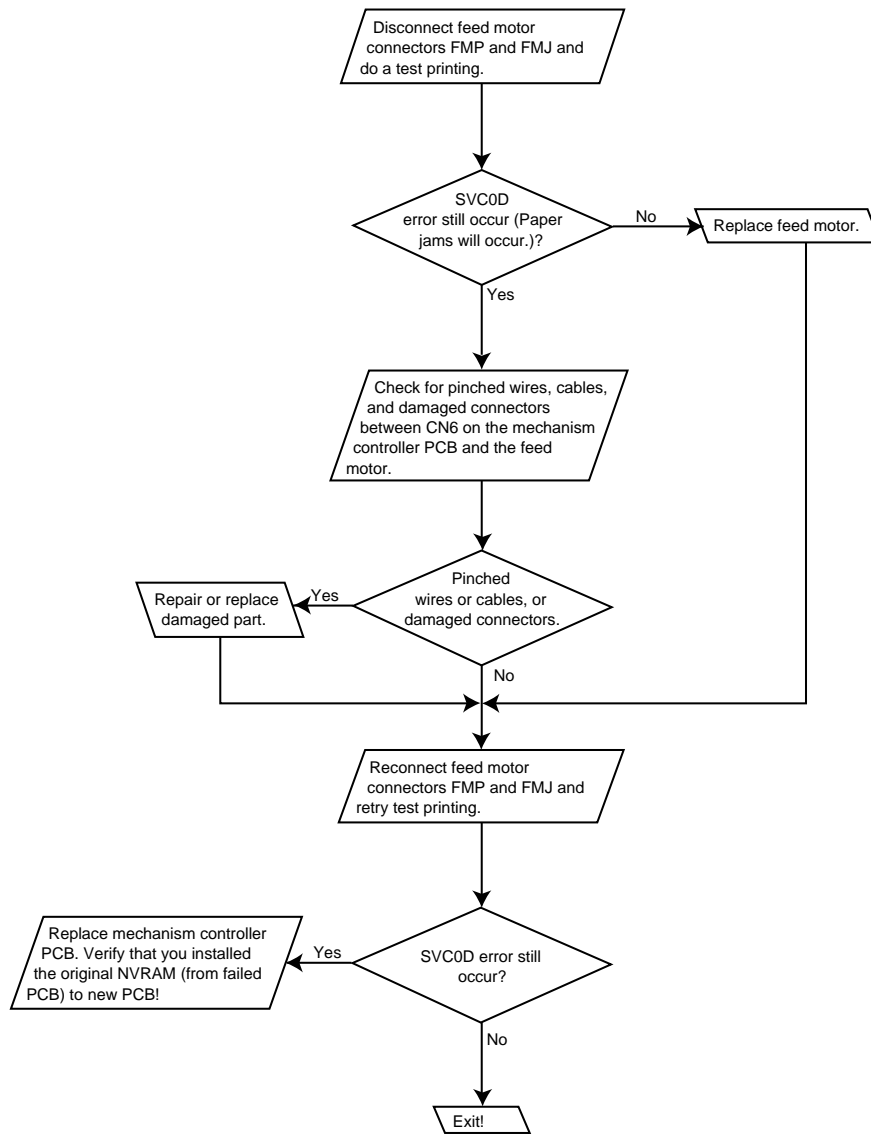

Figure 5-10. SVC0D Feed Motor Alarm Flow Chart

Reference Diagrams

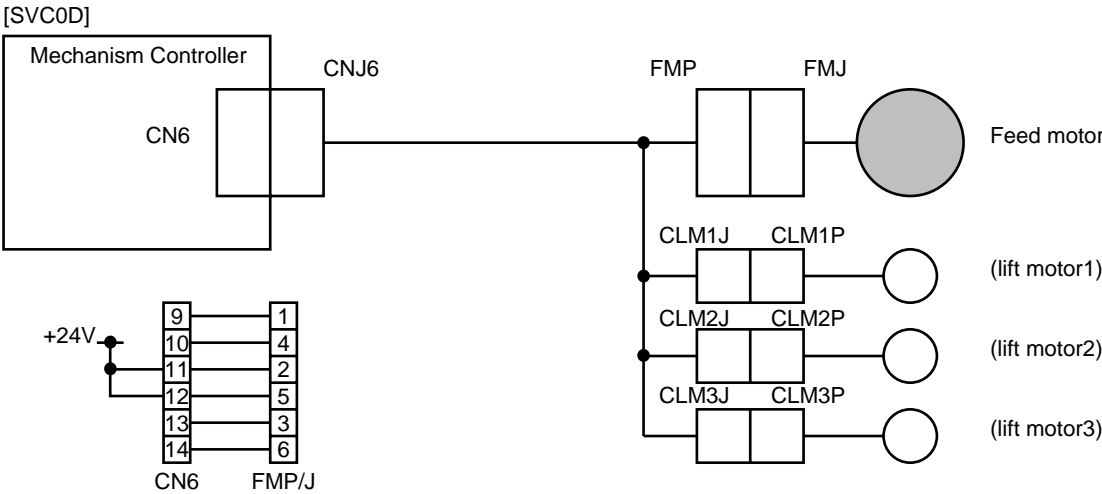

Figure 5-11. Feed Motor Alarm (SVC0D) Interconnections Diagram

5-2.6. SVC0E Stacker Select Solenoid Alarm

Explanation

An overcurrent of the stacker select solenoid of the reversing unit was detected in the mechanism controller. Note that if the selector or the solenoid itself is locked or clogged, the overcurrent is not occurred.

Troubleshooting Procedure

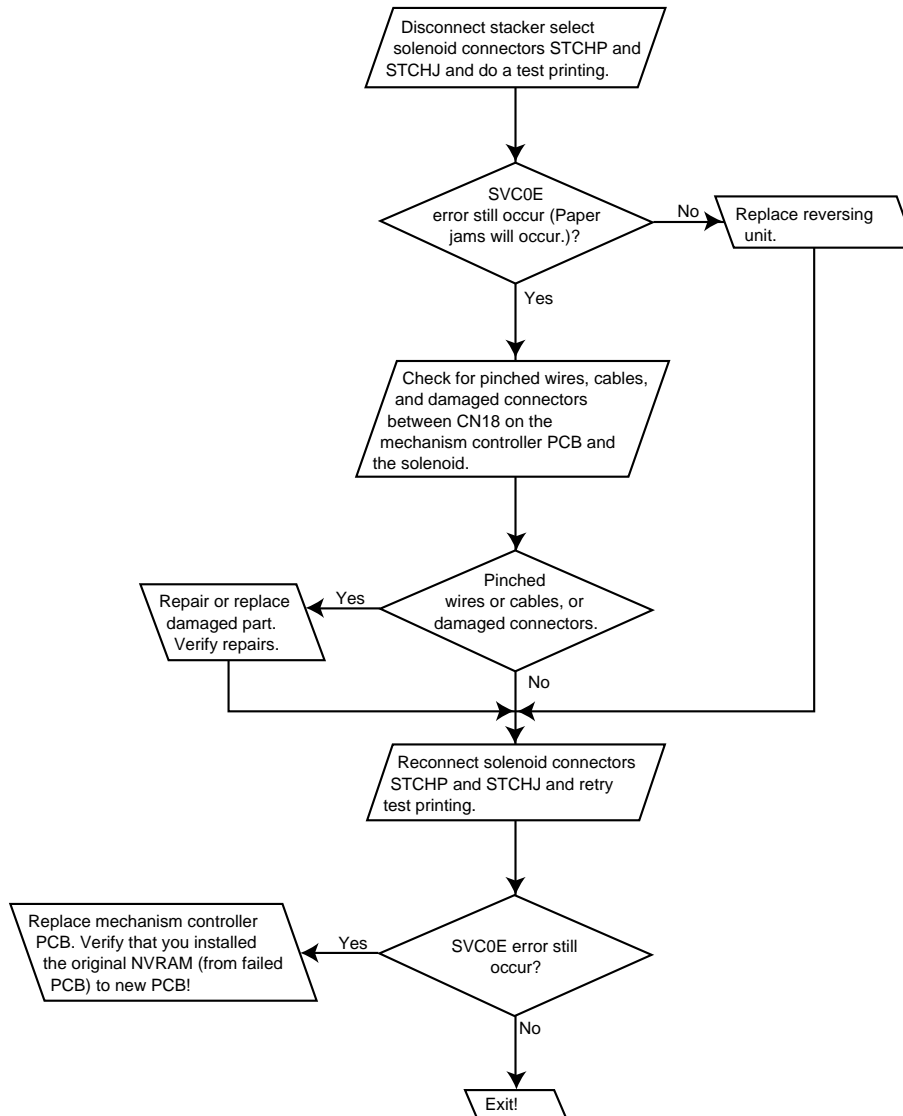

Figure 5-12. SVC0E Stacker Select Solenoid Alarm Flow Chart

Reference Diagrams

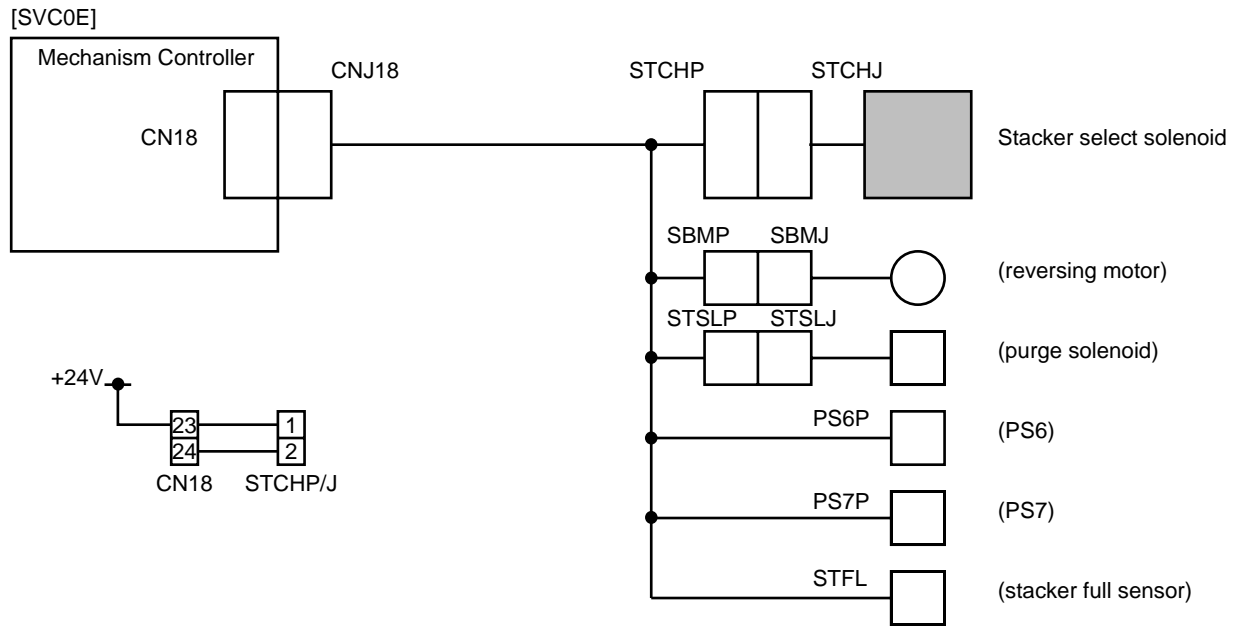

Figure 5-13. Stacker Select Solenoid Alarm (SVC0E) Interconnections Diagram

5-2.7. SVC0F Duplex Motor Alarm

Explanation

An overcurrent of the duplex motor (stepper motor) of the duplex unit was detected in the mechanism controller. Note that if any roller or shaft is locked or clogged, the overcurrent is not occurred.

Troubleshooting Procedure

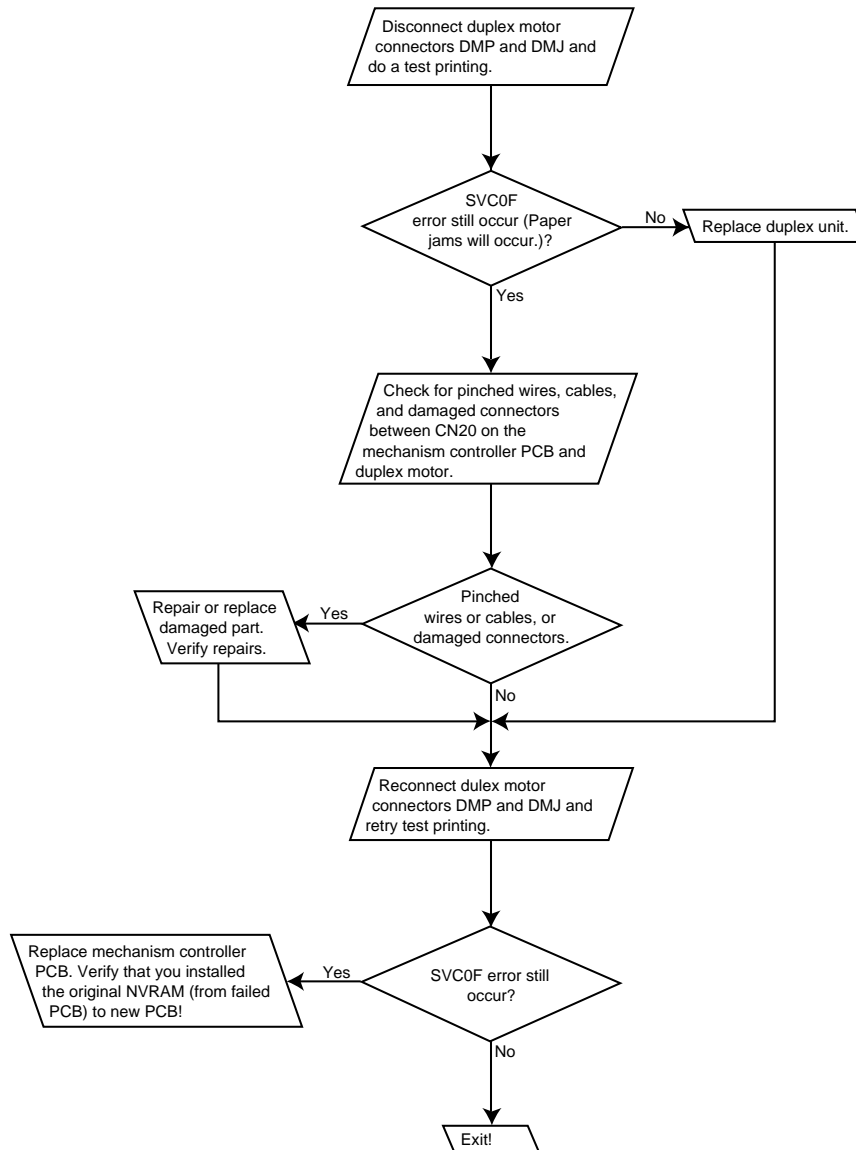

Figure 5-14. SVC0F Duplex Motor Alarm Flow Chart

Reference Diagrams

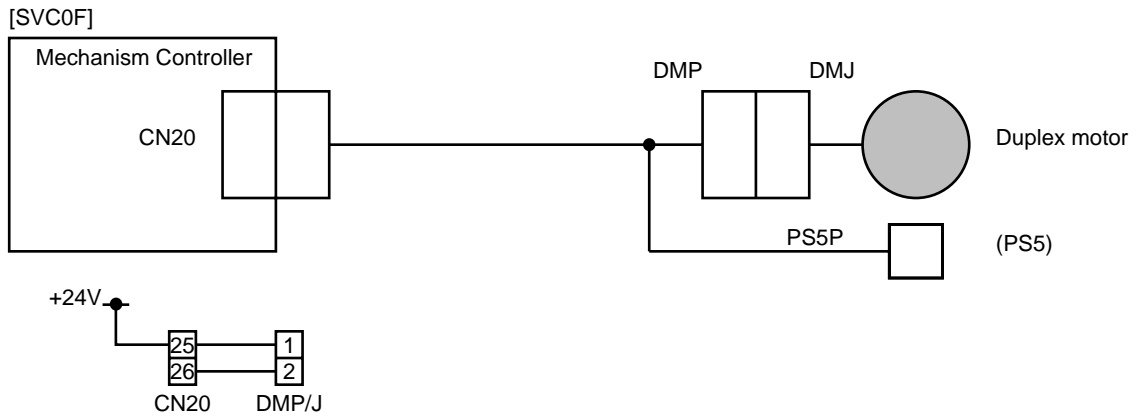

Figure 5-15. Duplex Motor Alarm (SVC0F) Interconnections Diagram

5-2.8. SVC27 Fuser Time-out Alarm

Explanation

It was detected from the thermistor in the fuser by the mechanism controller that the fuser unit did not reach the specified temperature (185 degC) when 200 seconds had passed after the power-on or cover closing.

Troubleshooting Procedure

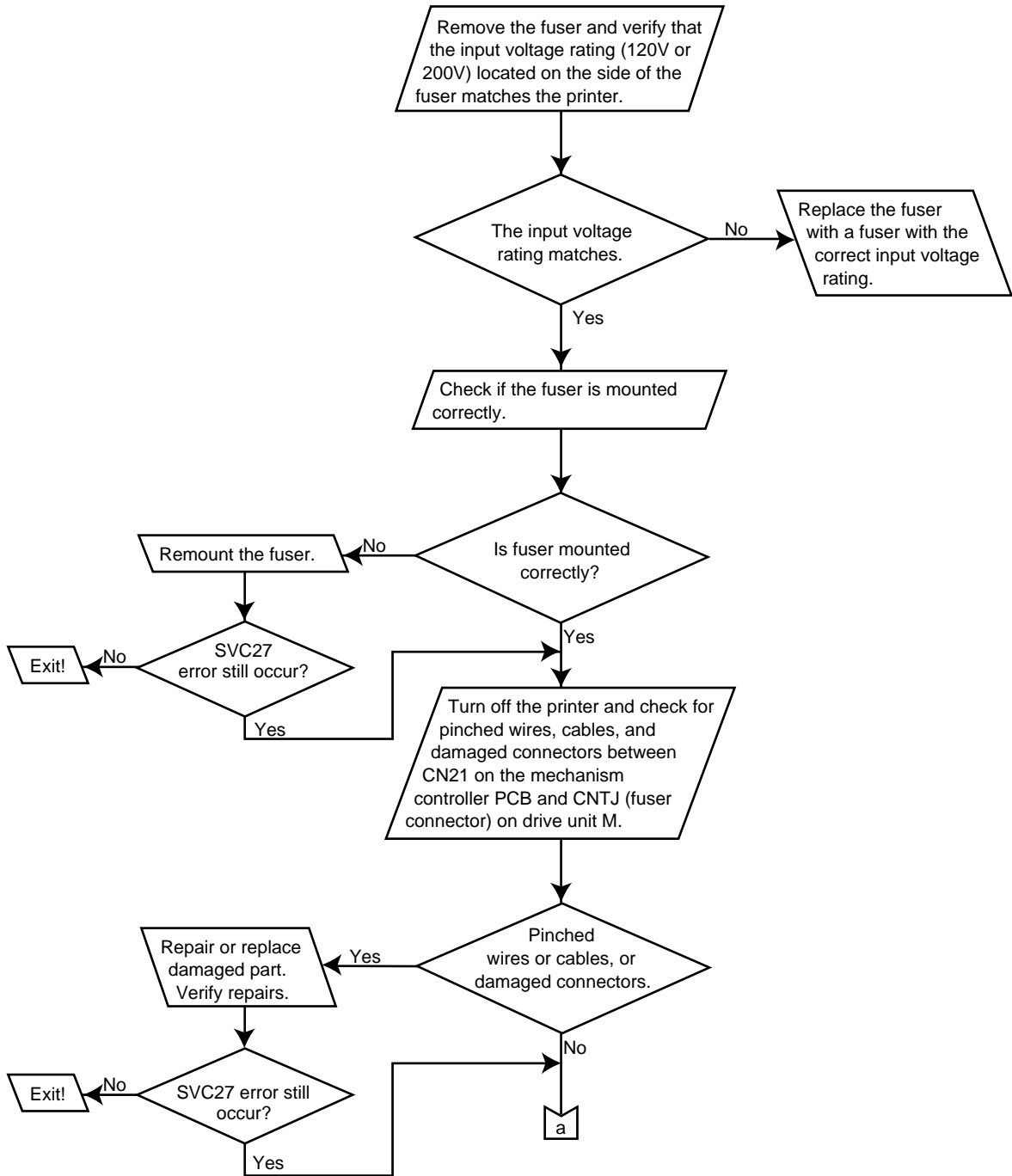

Figure 5-16. SVC27 Fuser Time-out Alarm Flow Chart (1 of 3)

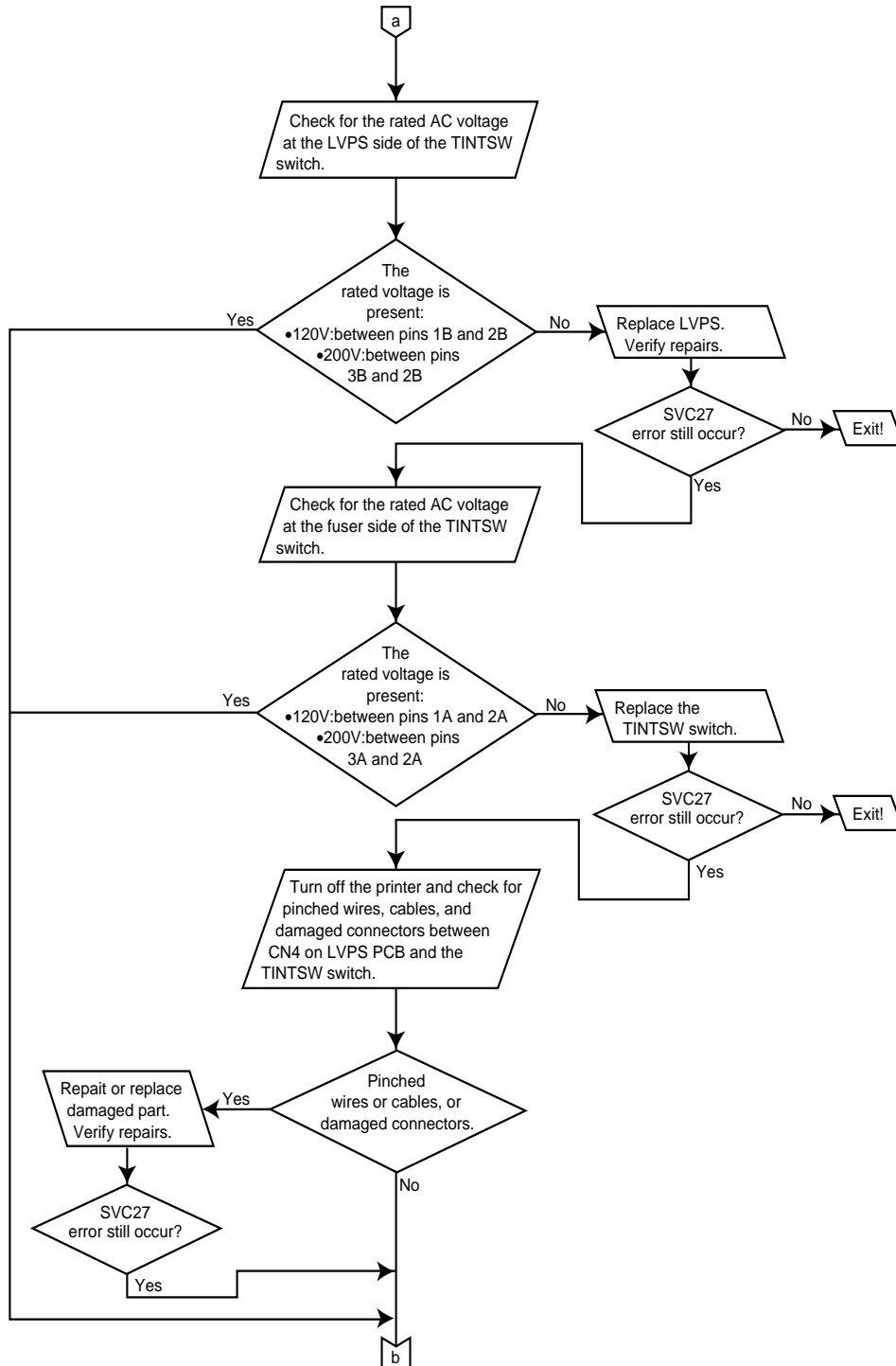

Figure 5-16. SVC27 Fuser Time-out Alarm Flow Chart (2 of 3)

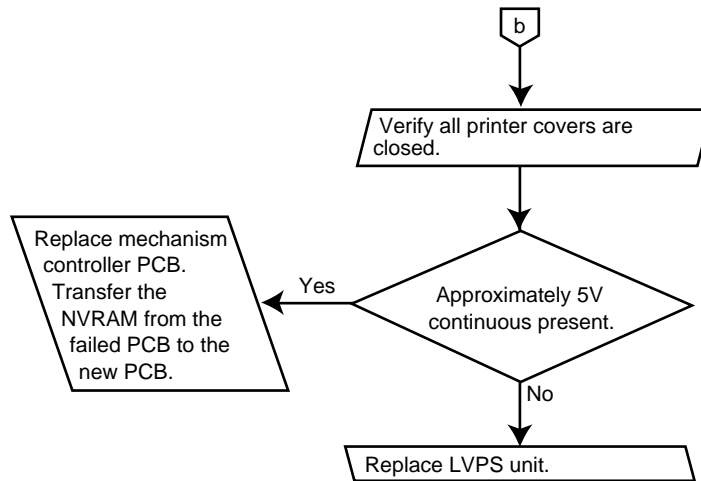

Figure 5-16. SVC27 Fuser Time-out Alarm Flow Chart (3 of 3)

Reference Diagrams

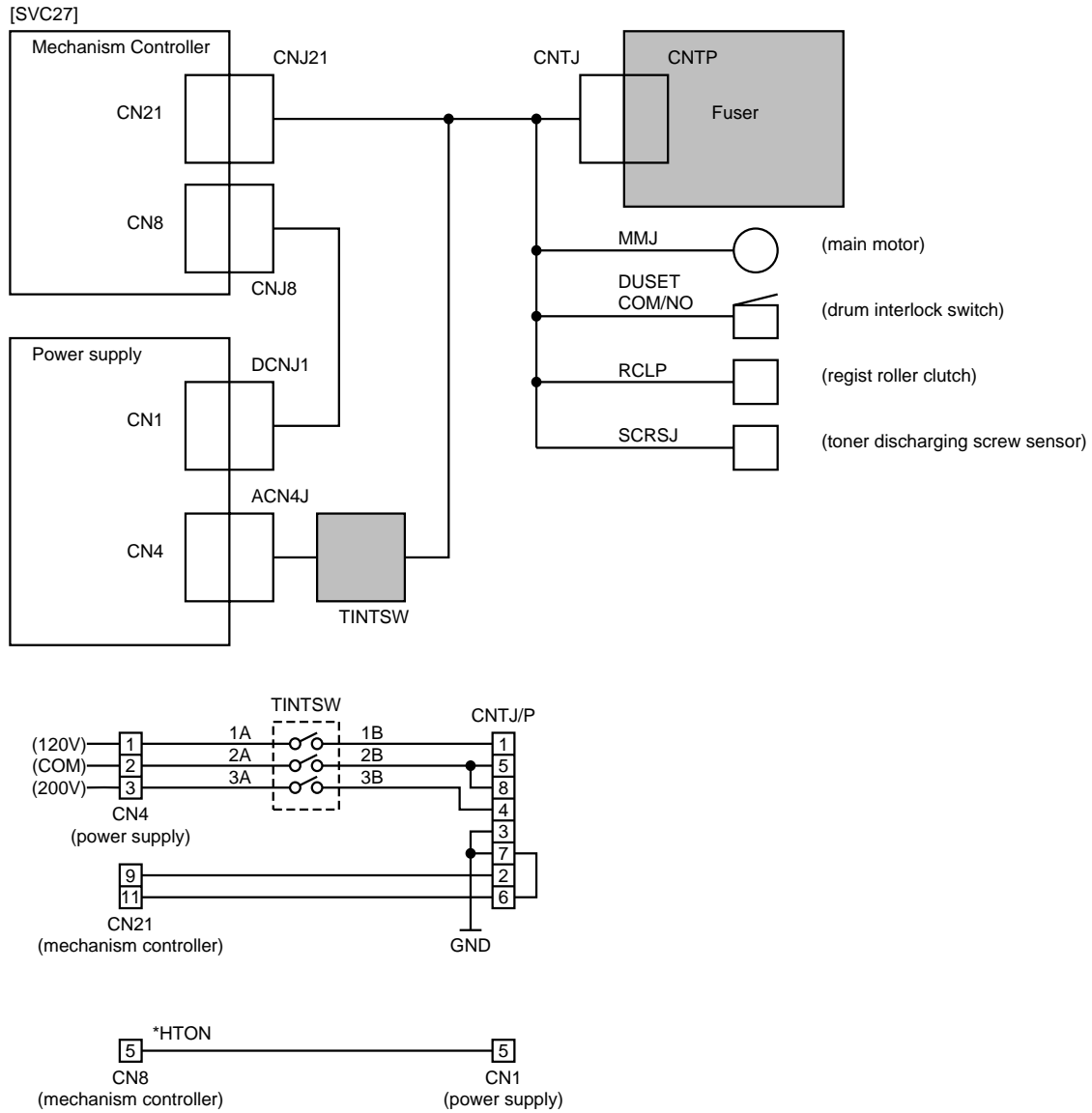

Figure 5-17. Fuser Time-out Alarm (SVC27) Interconnections Diagram

5-2.9. SVC28 Fuser High-temperature Alarm

Explanation

The fuser temperature is checked from the thermistor in the fuser by the mechanism controller every 500 ms. A temperature of 225 degC or higher was detected twice consecutively.

Troubleshooting Procedure

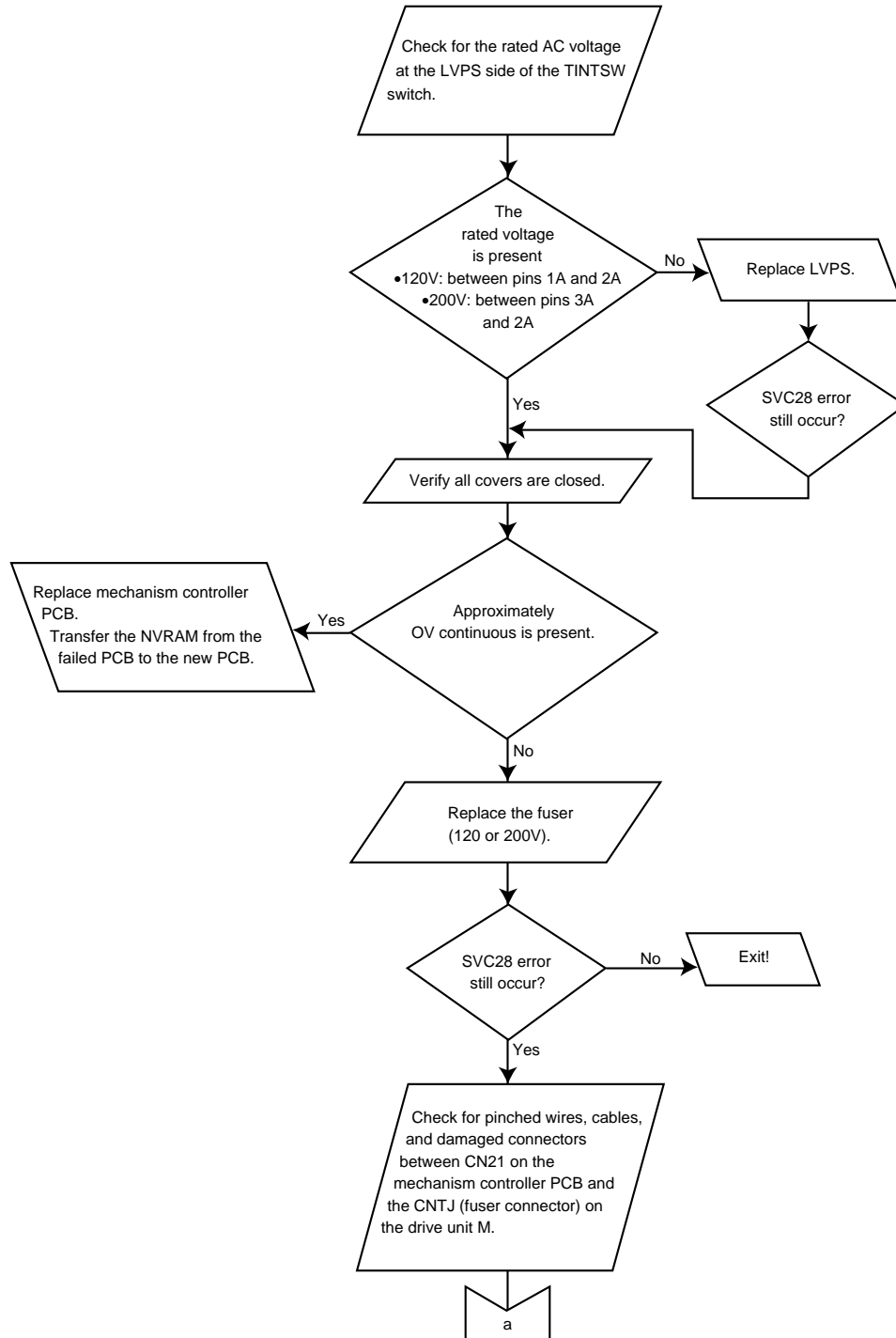

Figure 5-18. SVC28 Fuser High-temperature Alarm Flow Chart (1 of 2)

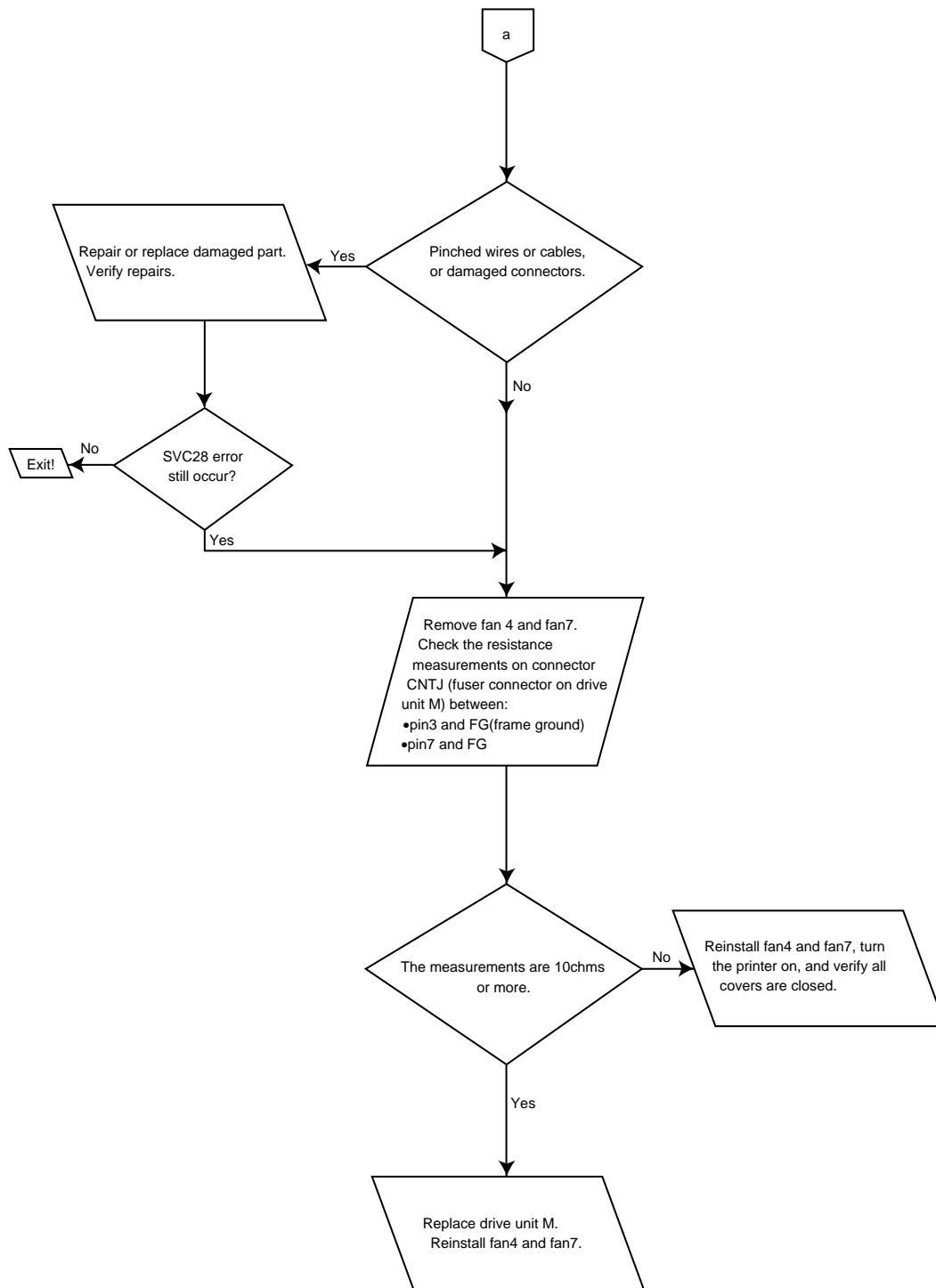

Figure 5-18. SVC28 Fuser High-temperature Alarm Flow Chart (2 of 2)

Reference Diagrams

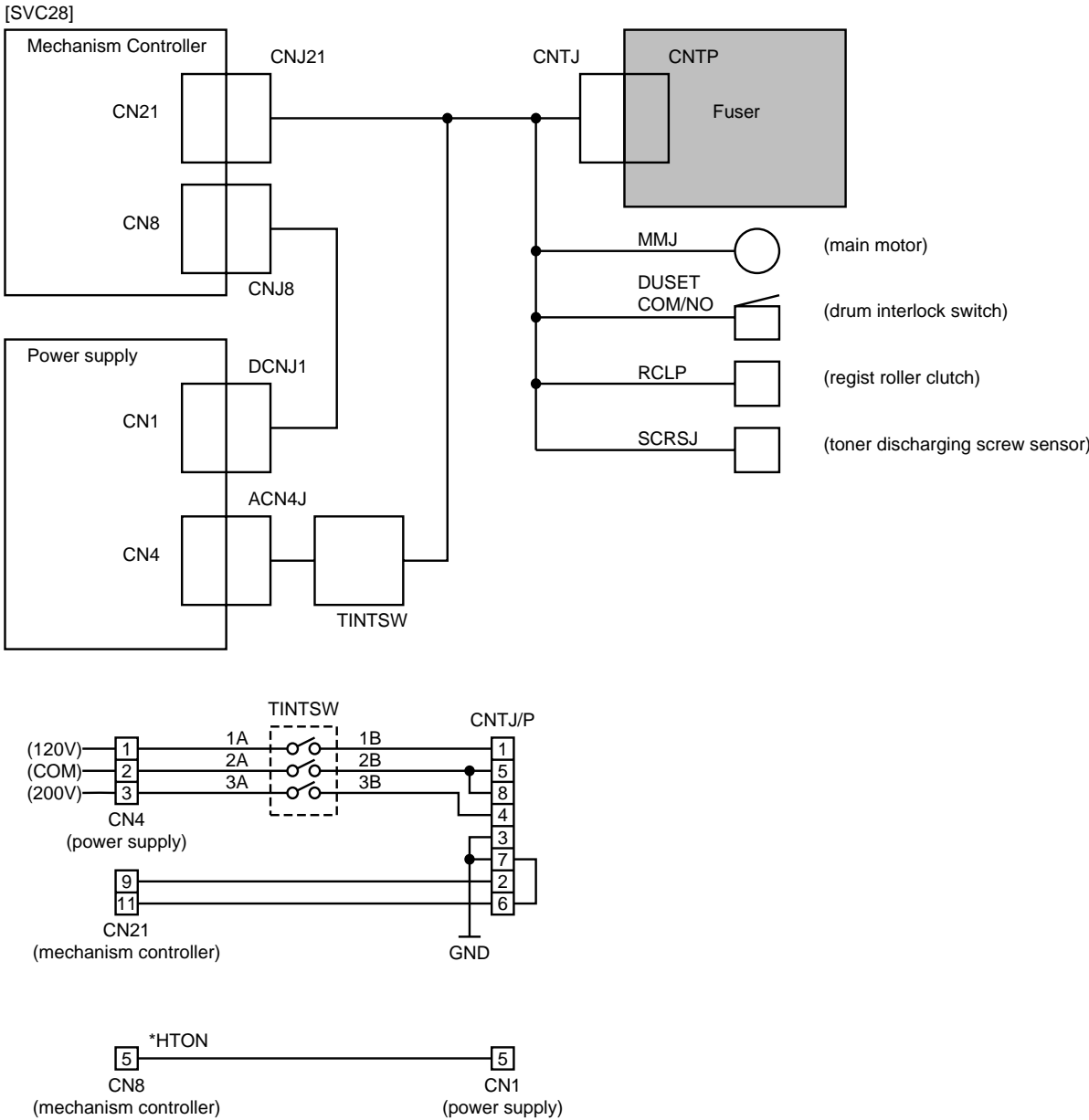

Figure 5-19. Fuser High-temperature Alarm (SVC28) Interconnections Diagram

5-2.10. SVC29 Fuser Low-temperature Alarm

Explanation

The fuser unit temperature is checked from the thermistor in the fuser by the mechanism controller every 500 ms. A temperature of 155 degC or lower was detected twice consecutively.

Troubleshooting Procedure

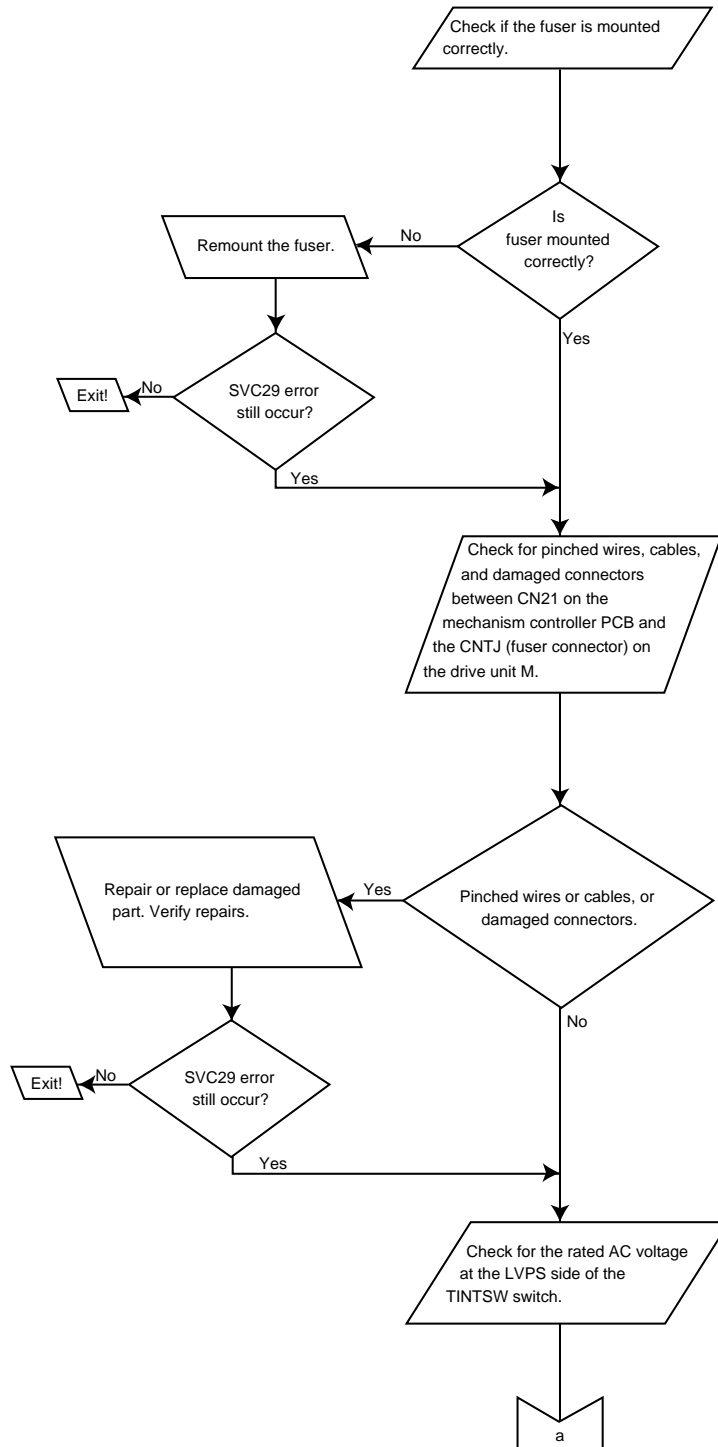

Figure 5-20. SVC29 Fuser Low-temperature Alarm Flow Chart (1 of 3)

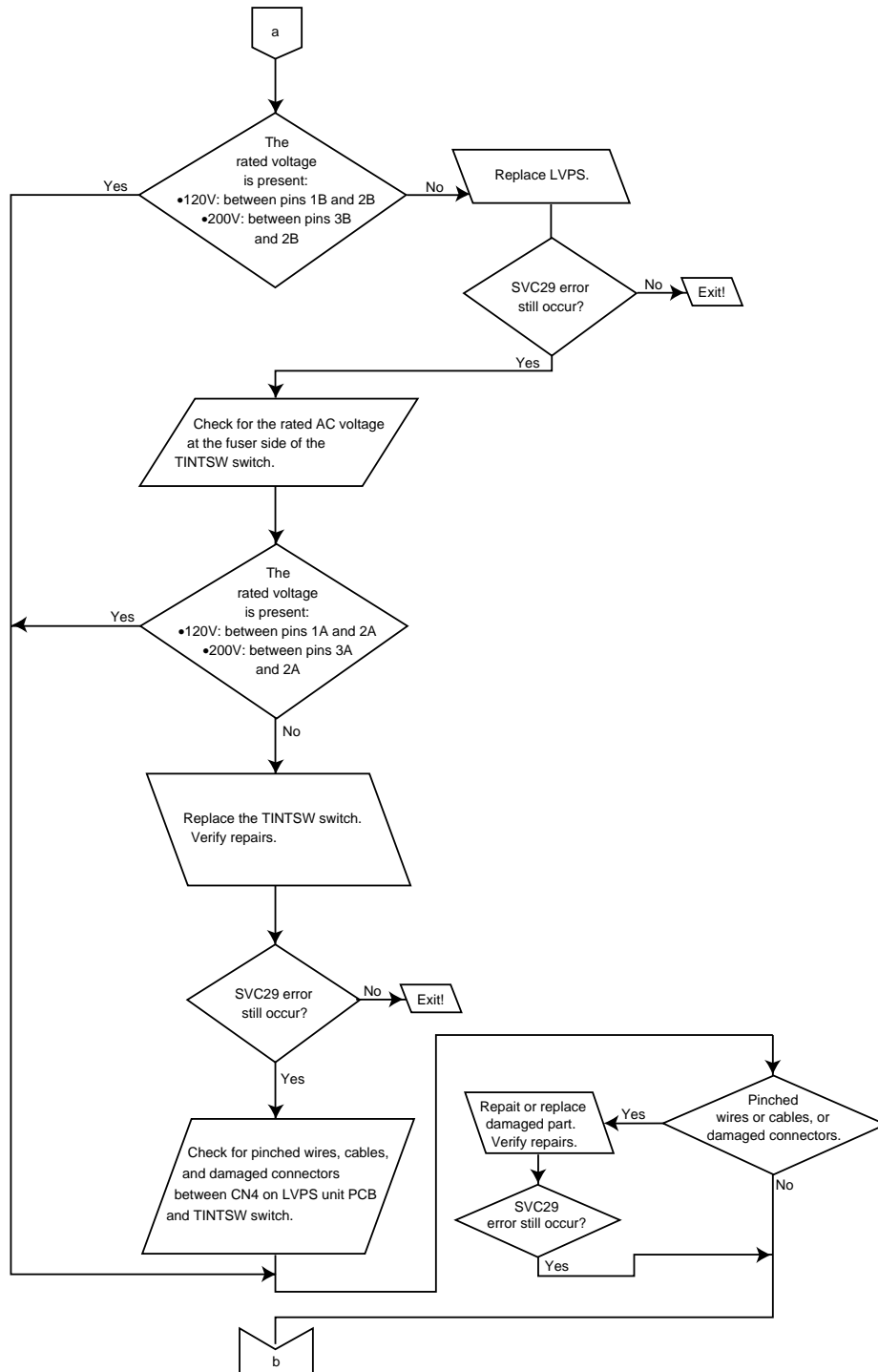

Figure 5-20. SVC29 Fuser Low-temperature Alarm Flow Chart (2 of 3)

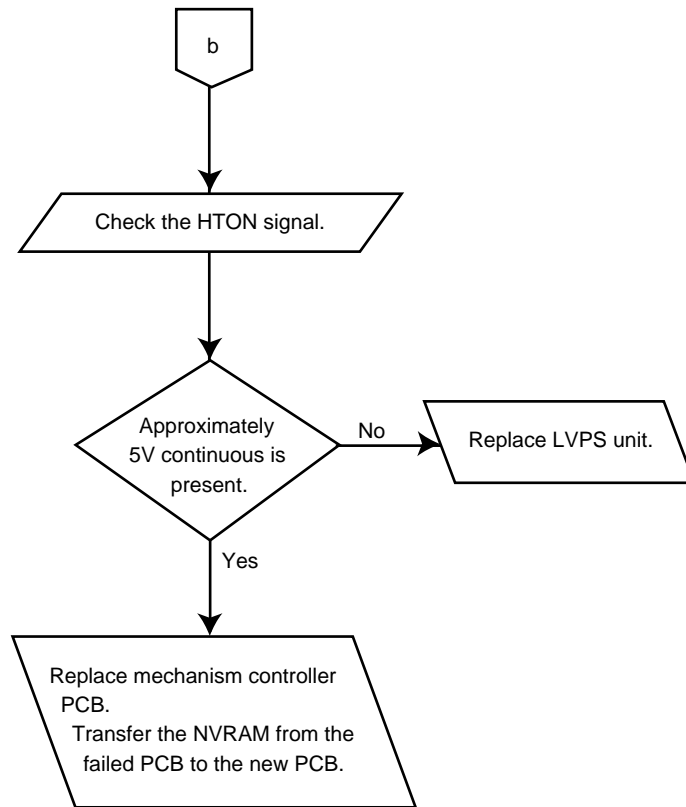

Figure 5-20. SVC29 Fuser Low-temperature Alarm Flow Chart (3 of 3)

Reference Diagrams

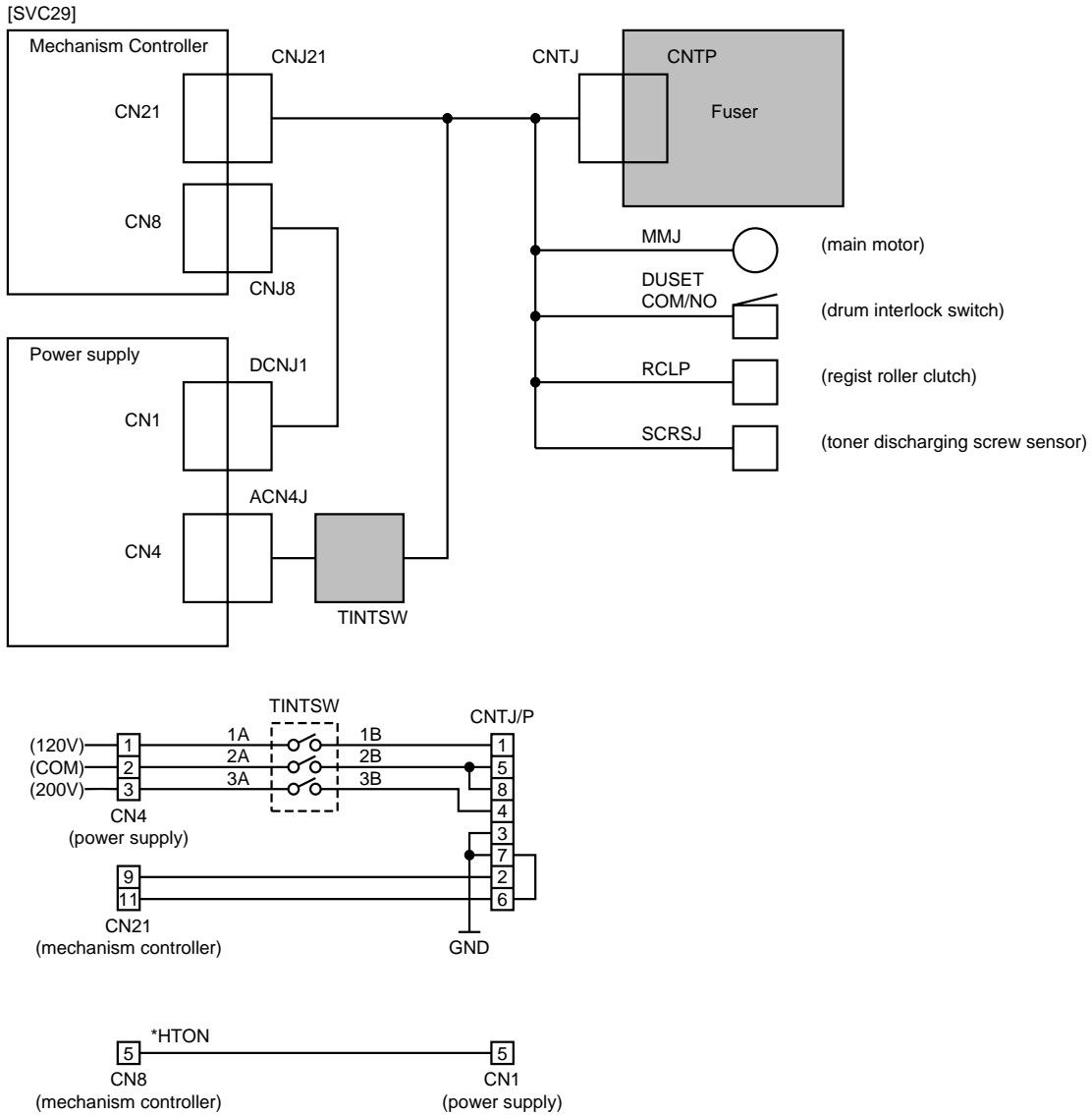

Figure 5-21. Fuser Low-temperature Alarm (SVC29) Interconnections Diagram

5-2.11. SVC50 Toner Motor Alarm

Explanation

An overcurrent of the toner motor (DC motor) of the toner hopper was detected in the mechanism controller.

Troubleshooting Procedure

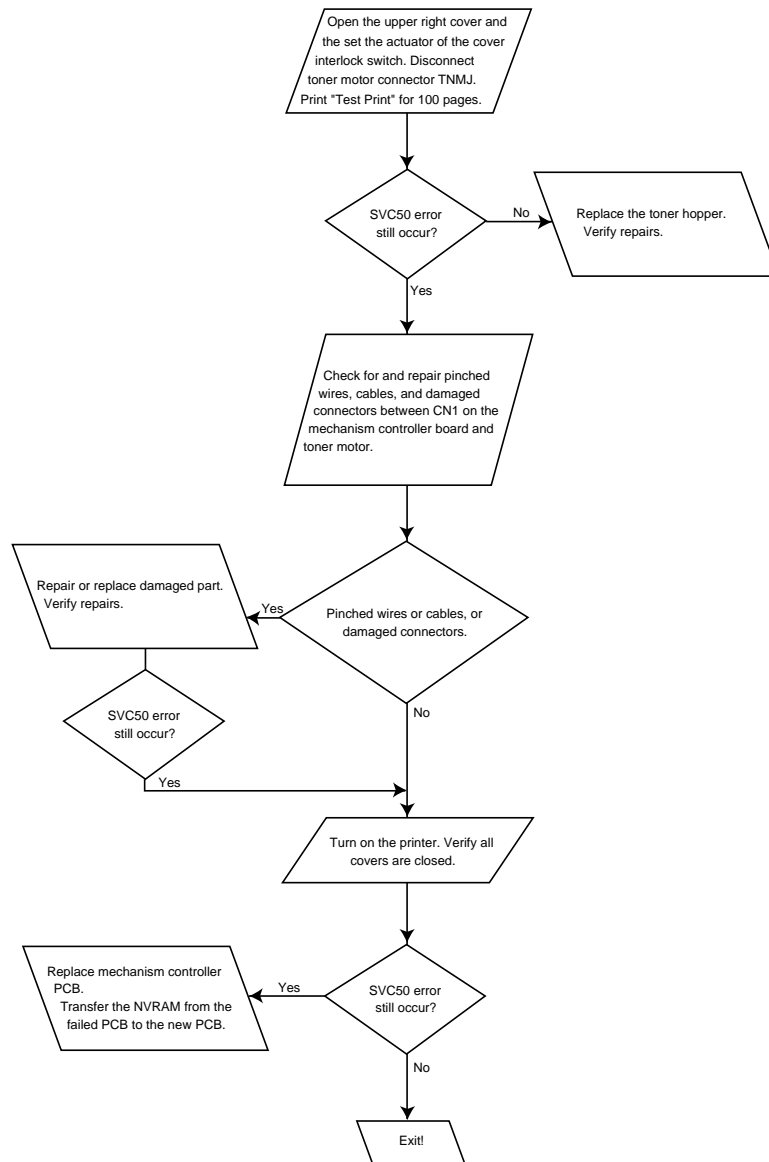

Figure 5-22. SVC50 Toner Motor Alarm Flow Chart

Reference Diagrams

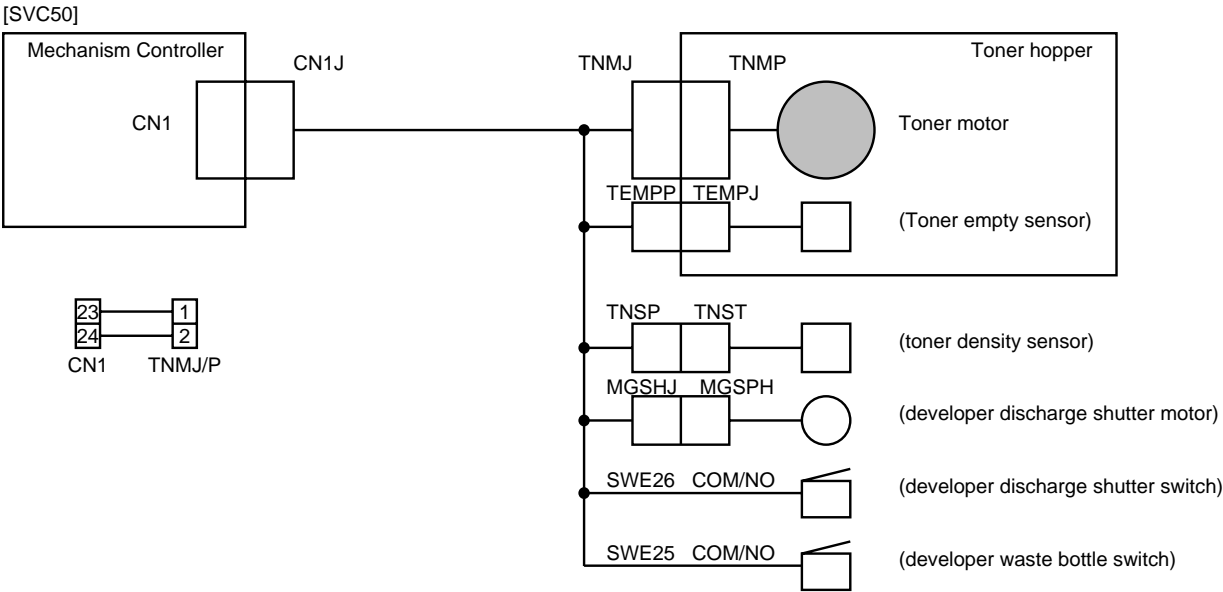

Figure 5-23. Toner Motor Alarm (SVC50) Interconnections Diagram

5-2.12. SVC51 Toner Discharge Screw Alarm

Explanation

It was detected from the toner discharging screw sensor by the mechanism controller that the toner discharge screw did not rotate unless the main motor rotated.

Troubleshooting Procedure

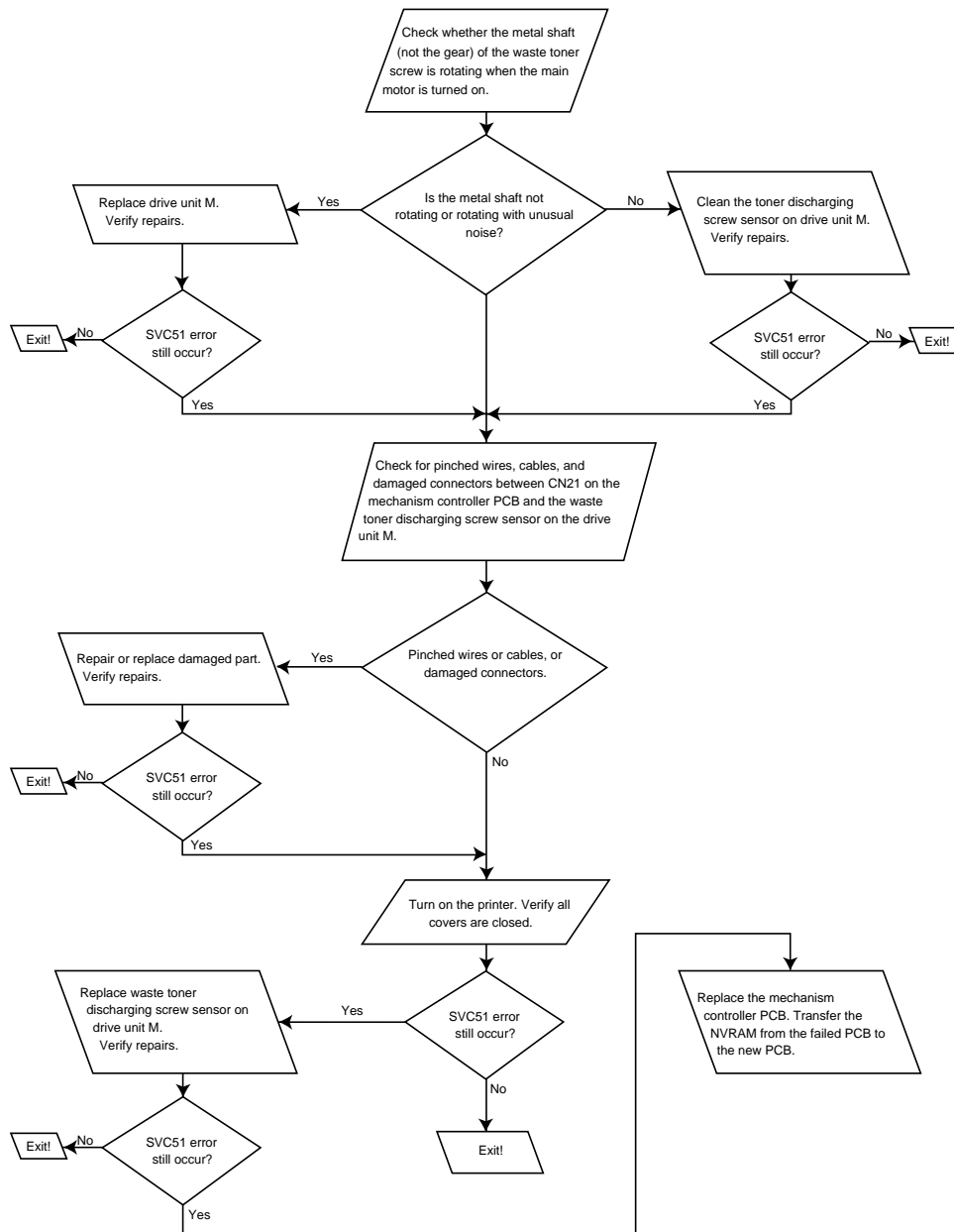

Figure 5-24. SVC51 Toner Discharge Screw Alarm Flow Chart

Reference Diagrams

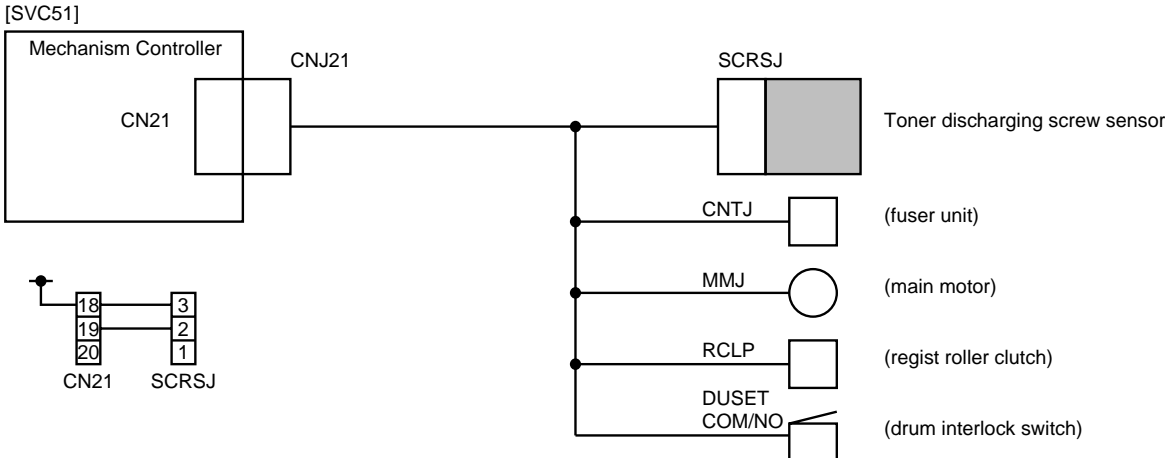

Figure 5-25. Toner Discharge Screw Alarm (SVC51) Interconnections Diagram

5-2.13. SVC52 Developer Discharge Alarm

Explanation

It was detected from the toner density sensor in the developing unit by the mechanism controller that the developer is in the developing unit unless the developer was discharged.

Troubleshooting Procedure

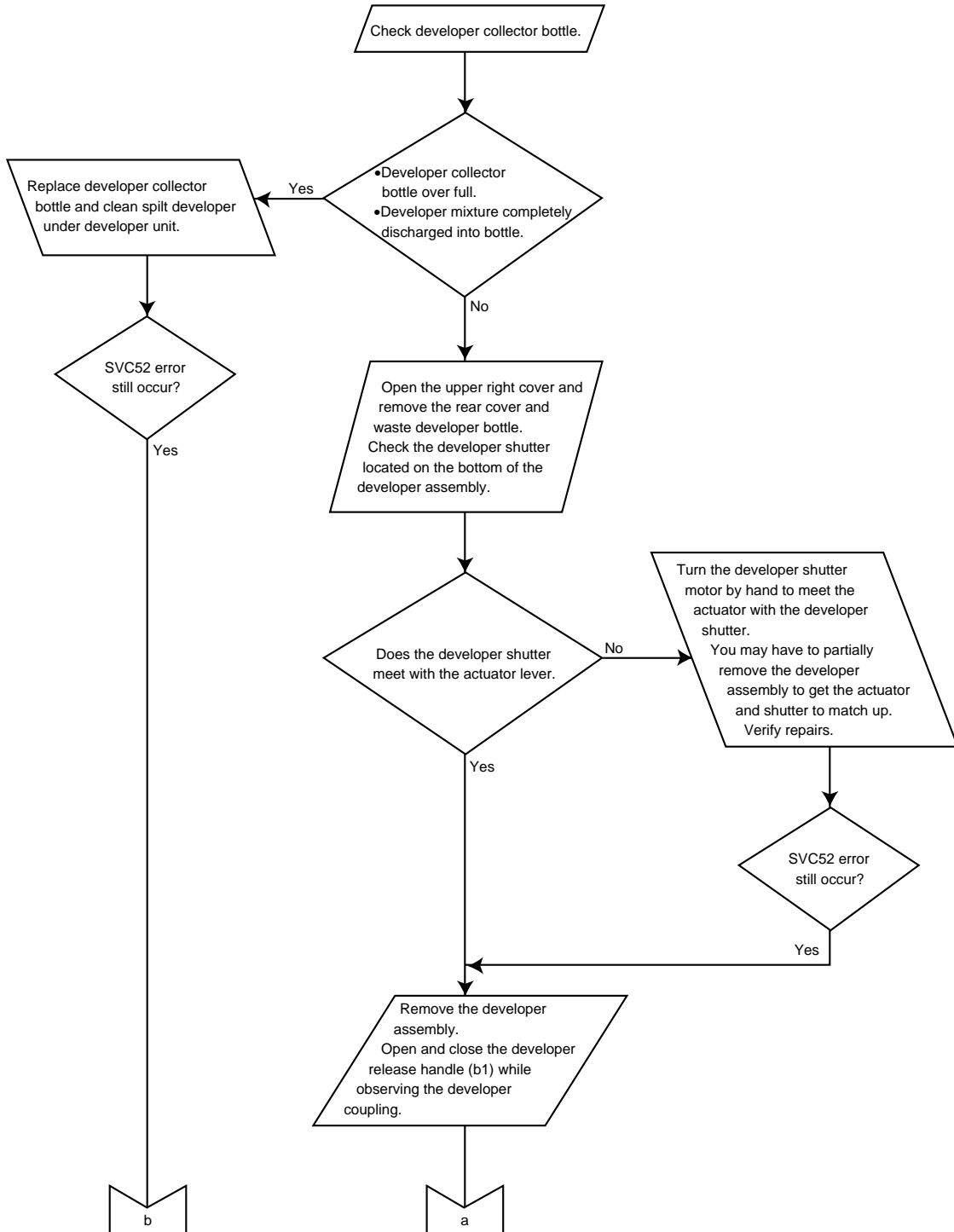

Figure 5-26. SVC52 Developer Discharge Alarm Flow Chart (1 of 3)

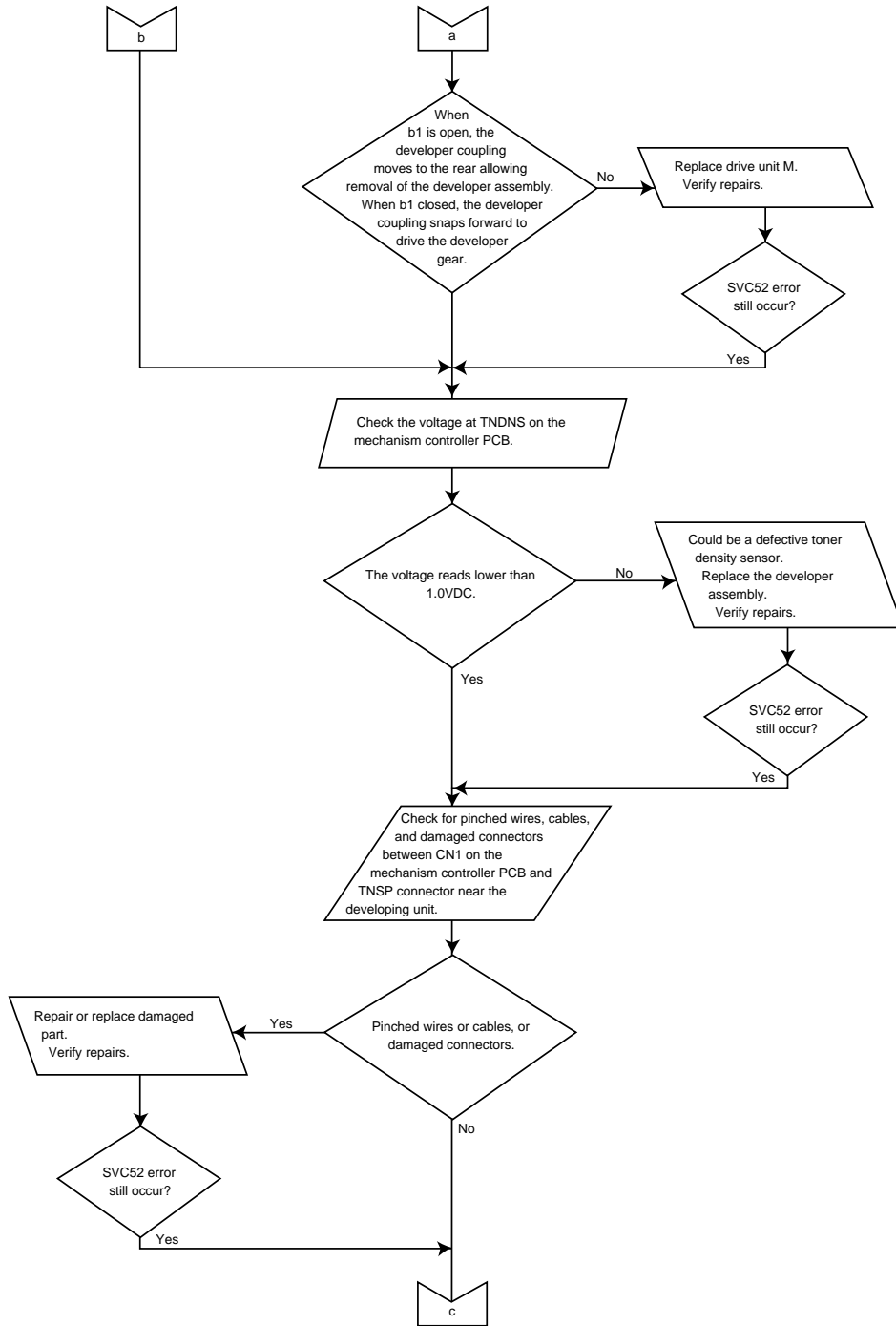

Figure 5-26. SVC52 Developer Discharge Alarm Flow Chart (2 of 3)

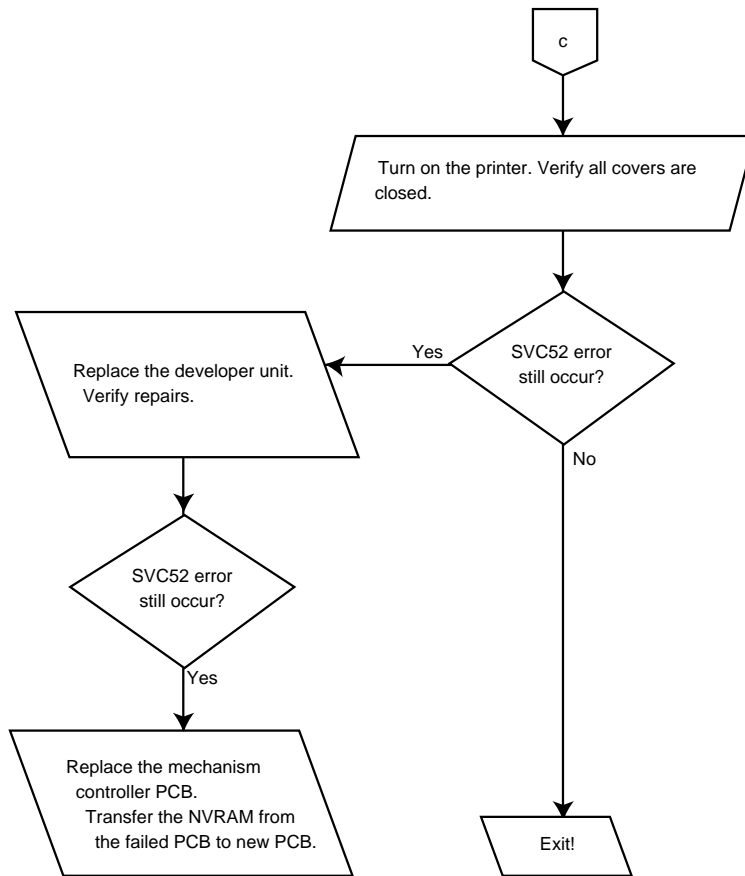

Figure 5-26. SVC52 Developer Discharge Alarm Flow Chart (3 of 3)

Reference Diagrams

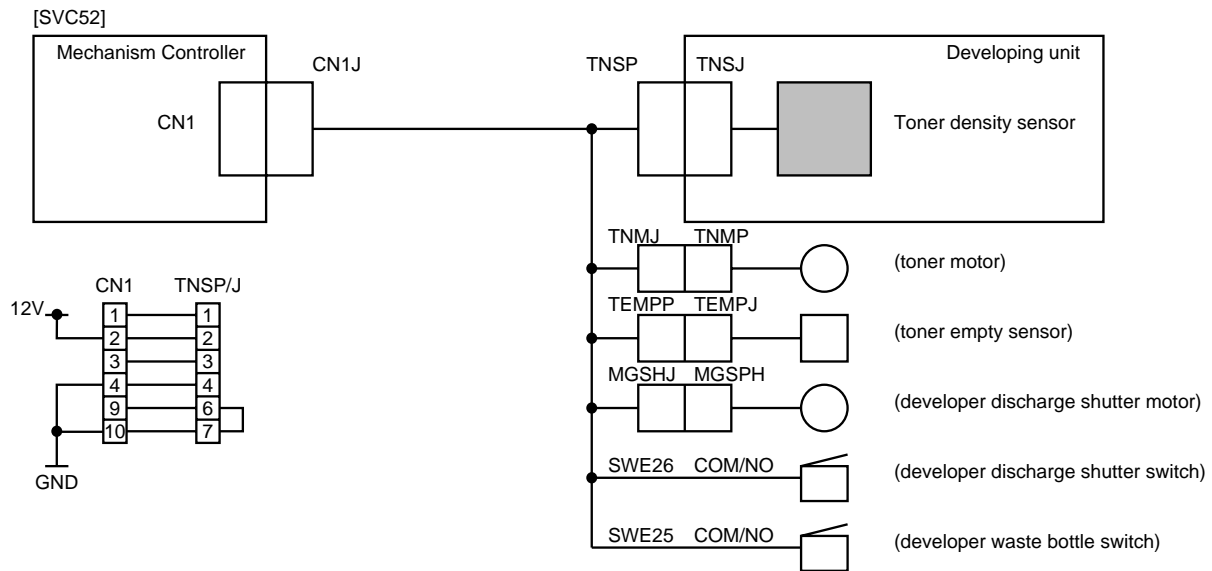

Figure 5-27. Developer Discharge Alarm (SVC52) Interconnections Diagram

5-2.14. SVC54 Developer Discharge Shutter Alarm

Explanation

It was detected from the developer discharge shutter switch by the mechanism controller that the developer discharge shutter does not open at the developer discharge sequence.

Troubleshooting Procedure

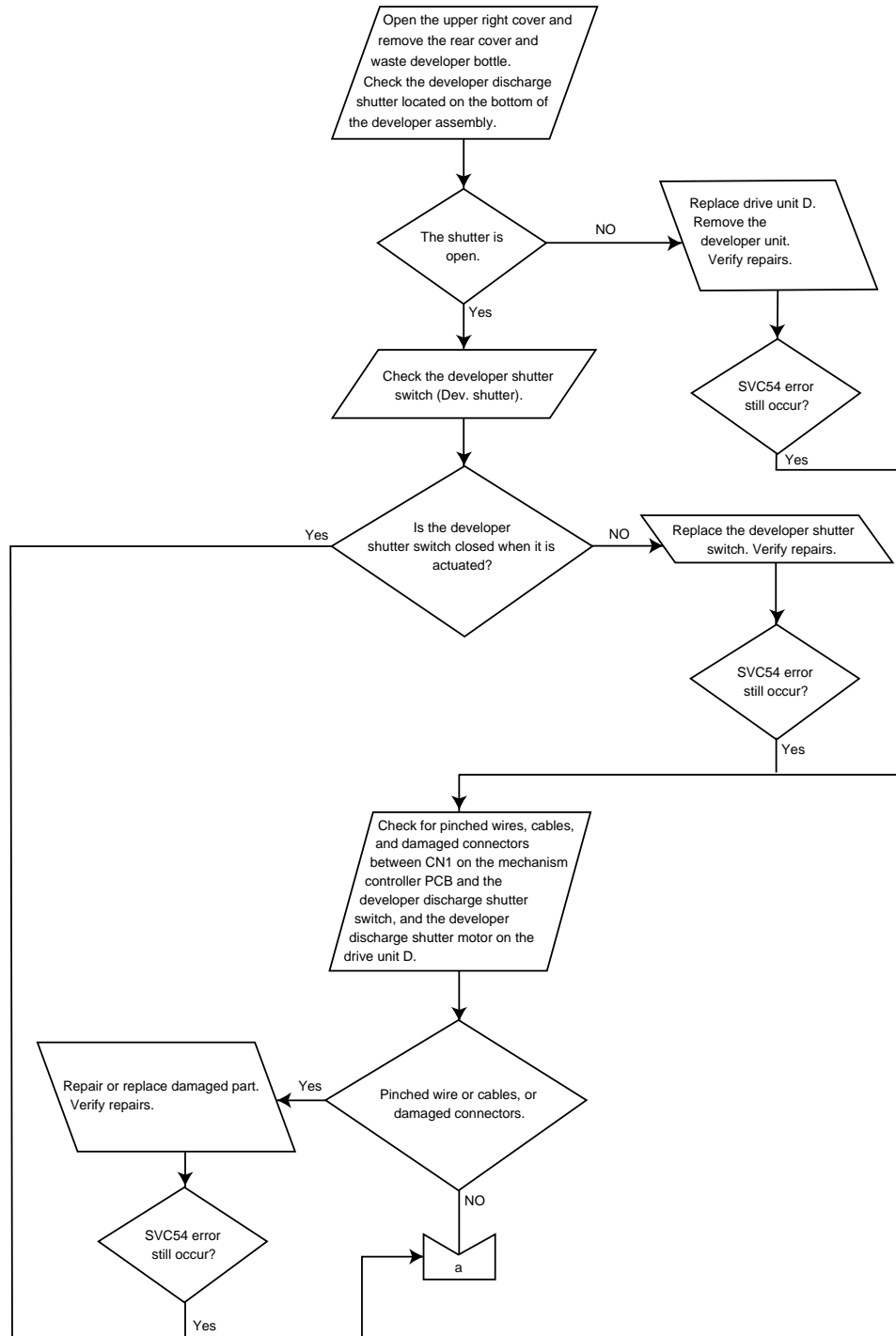

Figure 5-28. SVC54 Developer Discharge Shutter Alarm Flow Chart (1 of 2)

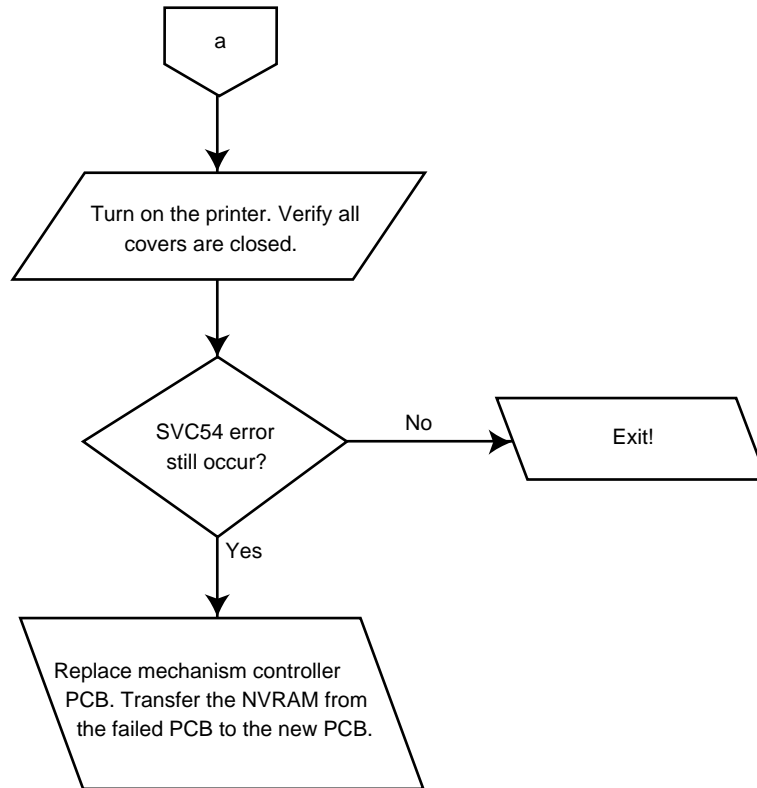

Figure 5-28. SVC54 Developer Discharge Shutter Alarm Flow Chart (2 of 2)

Reference Diagrams

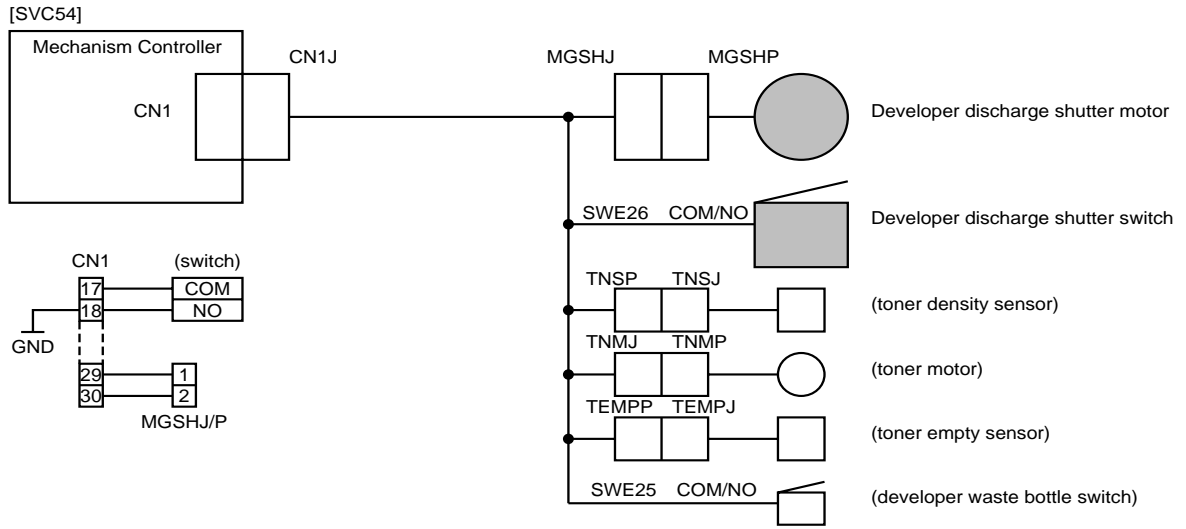

Figure 5-29. Developer Discharge Shutter Alarm (SVC54) Interconnections Diagram

5-2.15. SVC56 Automatic Adjustment Alarm**Explanation**

At the automatic toner density adjustment after developer replacement, it is detected by the mechanism controller that the toner density sensor output voltage (can be monitored at the test point TNDNS W5 on the mechanism controller PCB) is not $2.5 \pm 0.2V$.

Troubleshooting Procedure

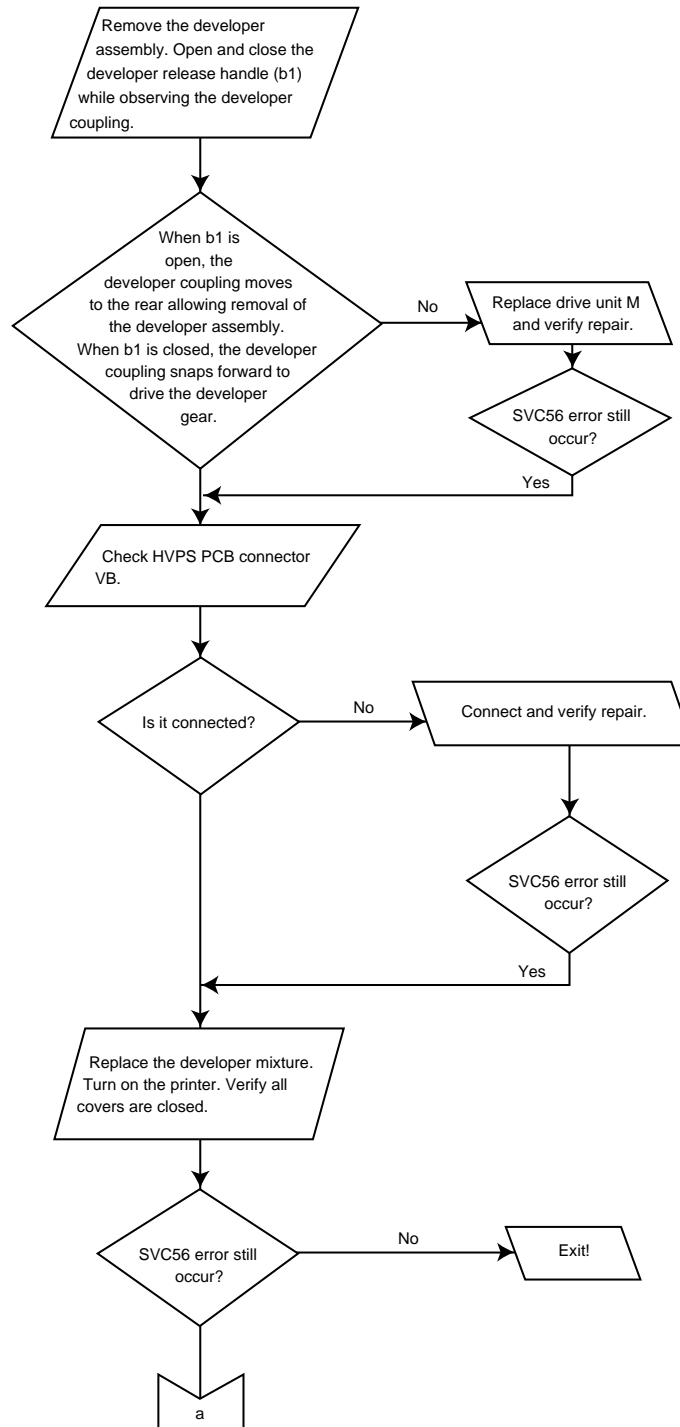

Figure 5-30. SVC56 Automatic Adjustment Alarm Flow Chart (1 of 3)

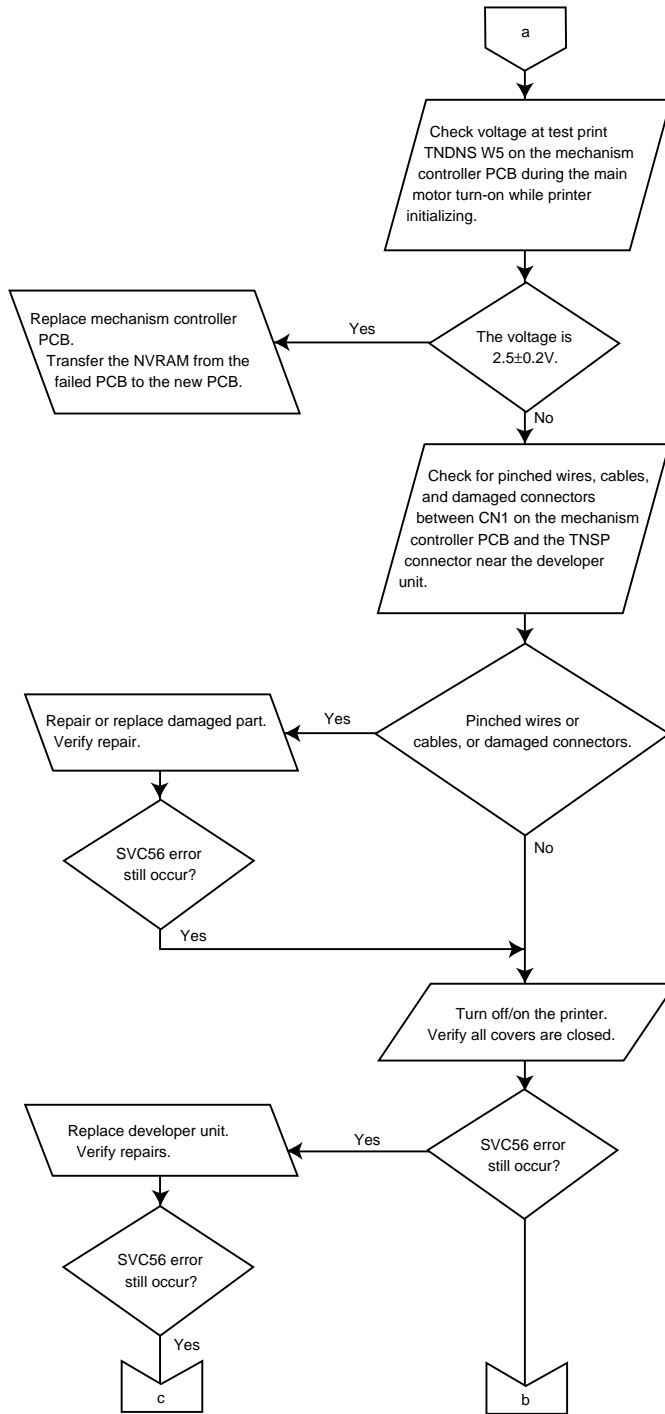

Figure 5-30. SVC56 Automatic Adjustment Alarm Flow Chart (2 of 3)

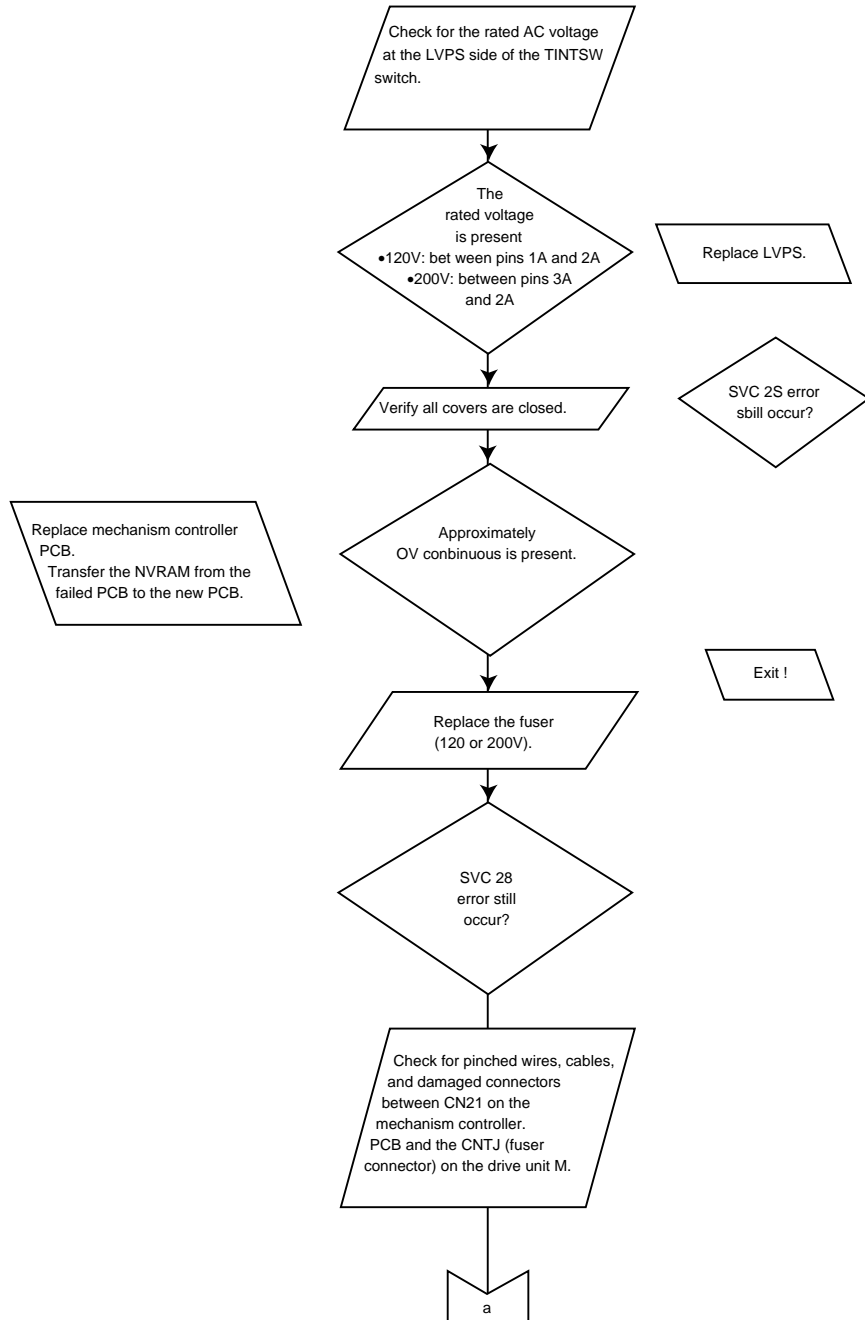

Figure 5-30. SVC56 Automatic Adjustment Alarm Flow Chart (3 of 3)

Reference Diagrams

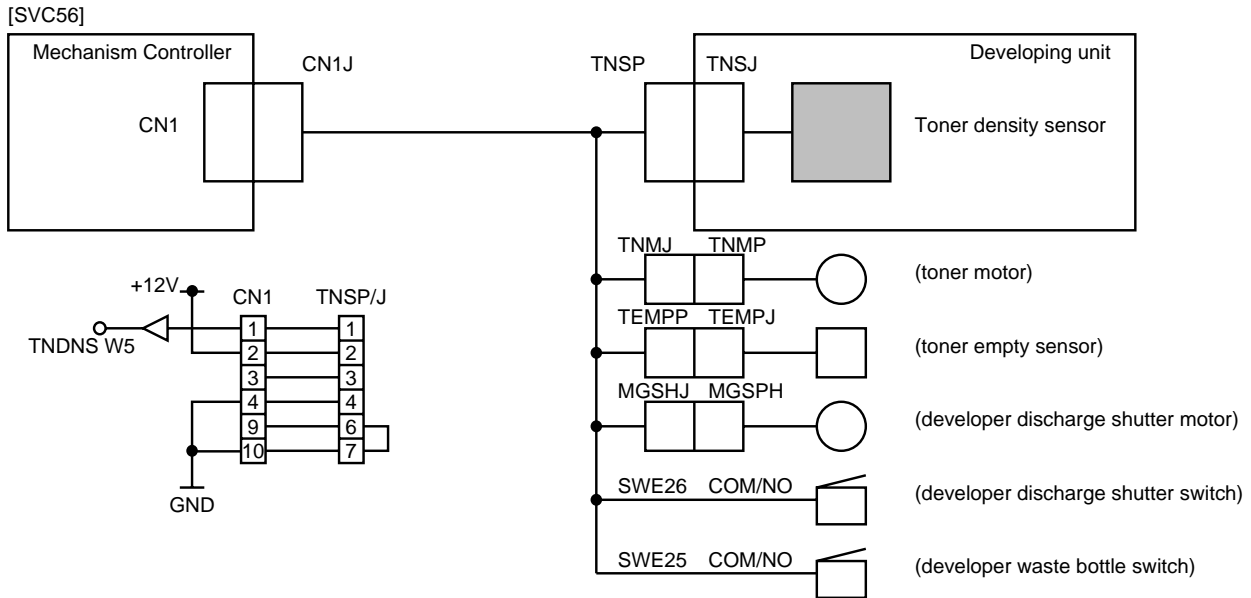

Figure 5-31. Automatic Adjustment Alarm (SVC56) Interconnections Diagram

5-2.16. SVC57 Toner High-density Alarm

Explanation

Abnormal toner density sensor output voltage (0.98V or lower, it can be monitored at the test point TNDNS W5 on the mechanism controller PCB) was detected four times consecutively by the mechanism controller. (The toner density sensor was checked every 500 ms by the mechanism controller.)

Troubleshooting Procedure

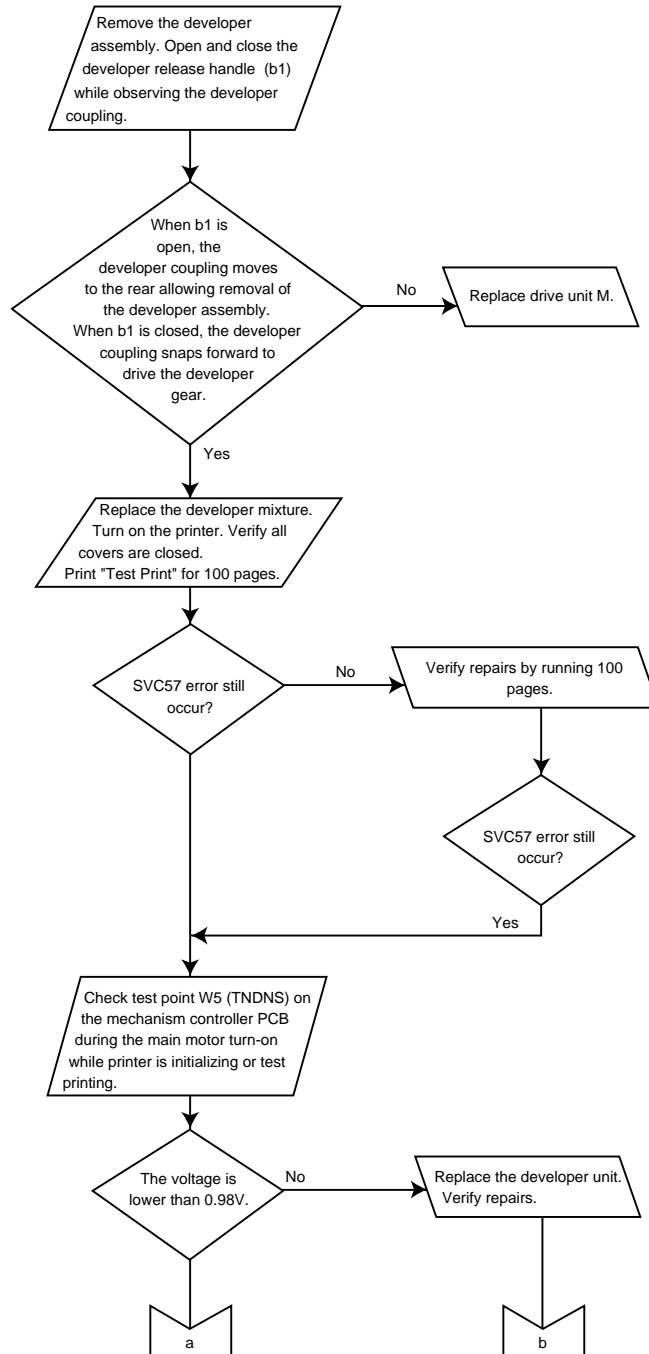

Figure 5-32. SVC57 Toner High-density Alarm Flow Chart (1 of 3)

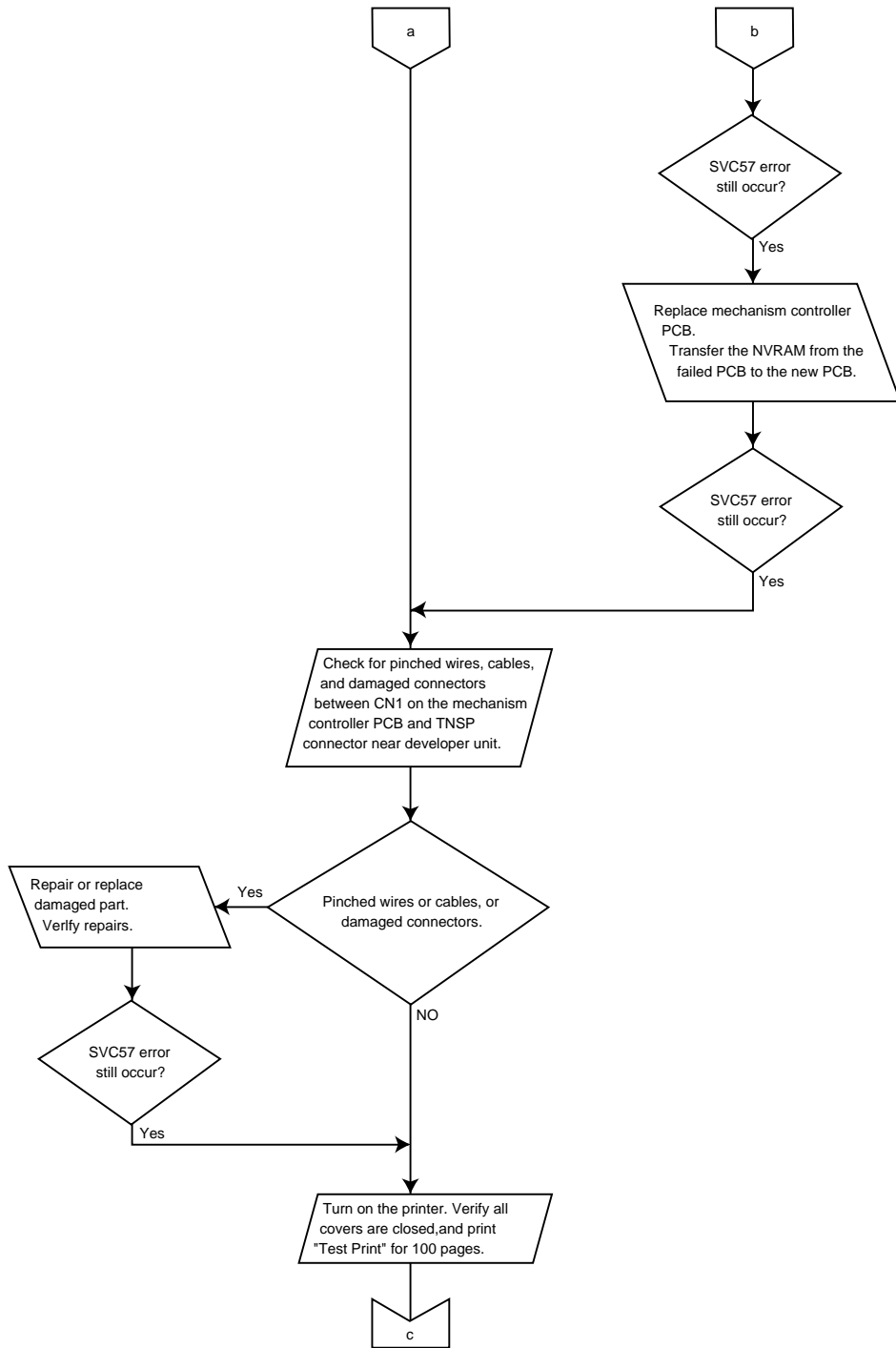

Figure 5-32. SVC57 Toner High-density Alarm Flow Chart (2 of 3)

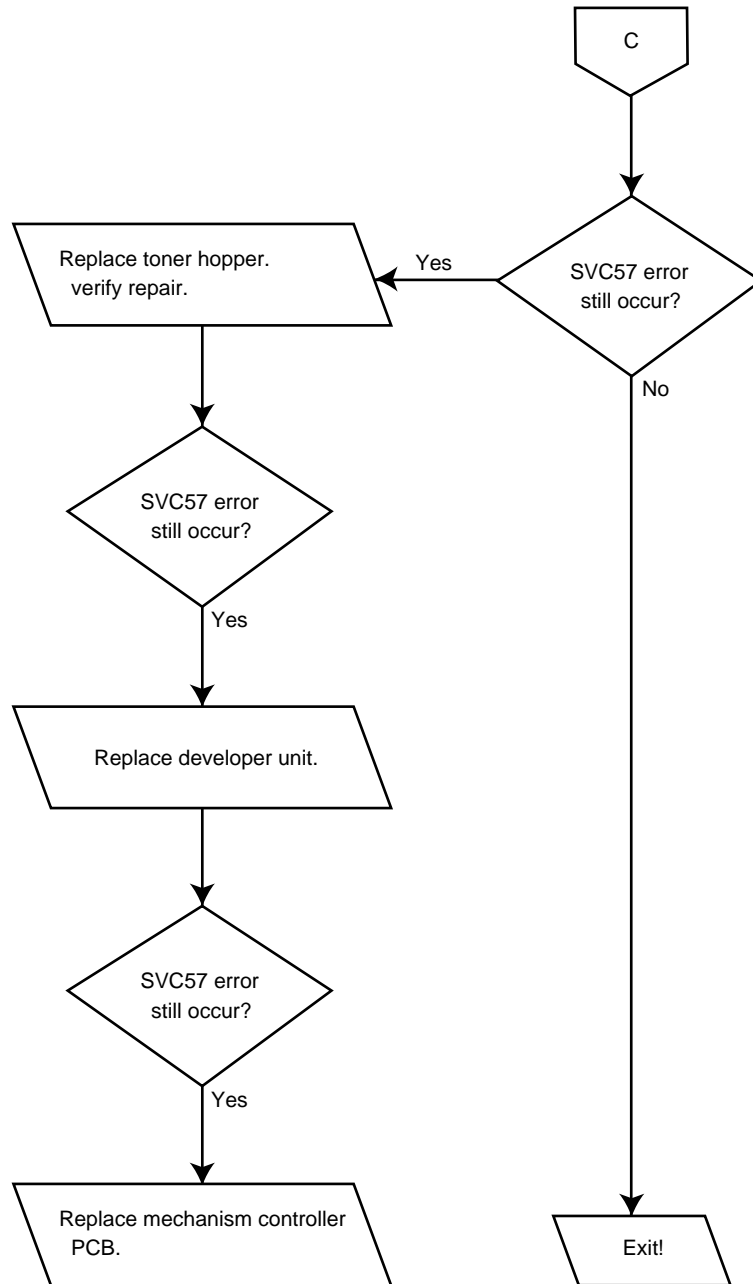

Figure 5-32. SVC57 Toner High-density Alarm Flow Chart (3 of 3)

Reference Diagram

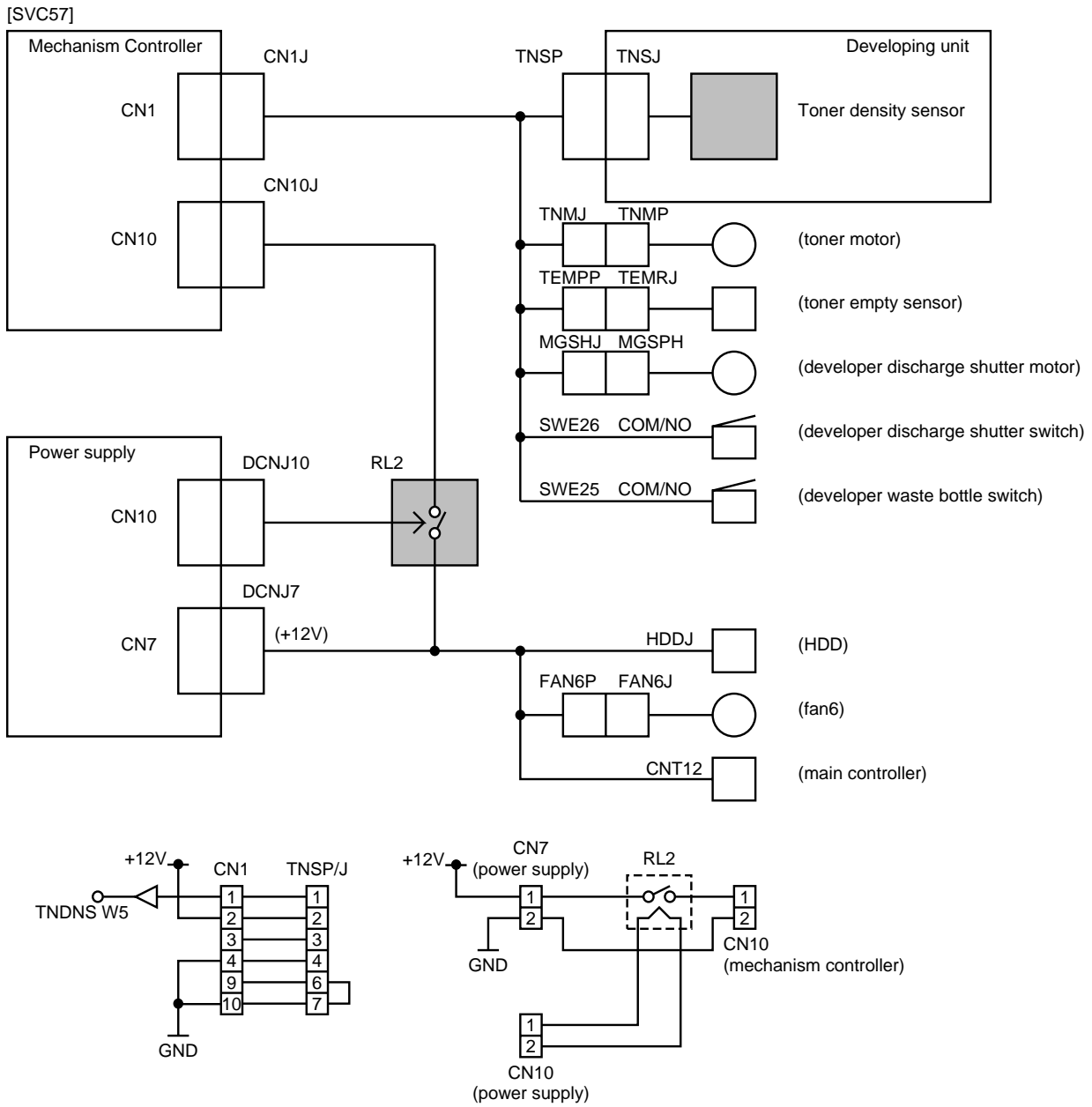

Figure 5-33. Toner High-density Alarm (SVC57) Interconnections Diagram

5-2.17. SVC58 Toner Low-density Alarm

Explanation

Abnormal toner density sensor output voltage (4.04V or higher, it can be monitored at the test point TNDNS W5 on the mechanism controller PCB) was detected four times consecutively by the mechanism controller. (The toner density sensor was checked every 500 ms by the mechanism controller.)

Note that this error may occurs when the printing is continued without supplying toner while clearing the “toner empty” message for many times.

Troubleshooting Procedure

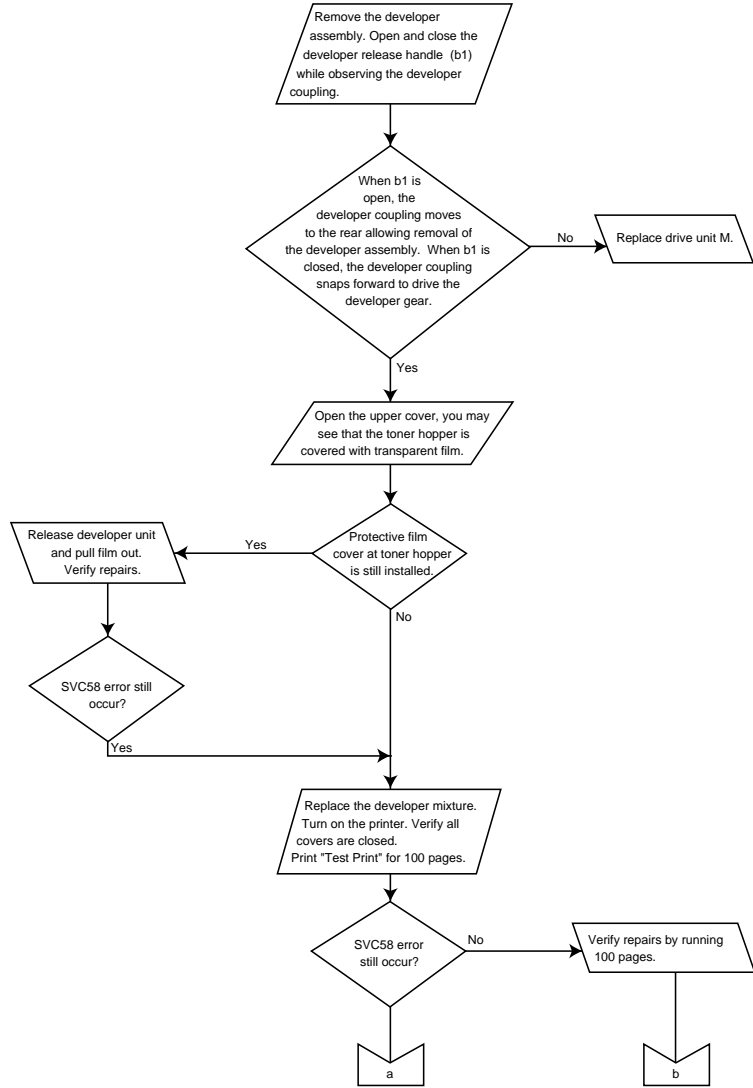

Figure 5-34. SVC58 Toner Low-density Alarm Flow Chart (1 of 3)

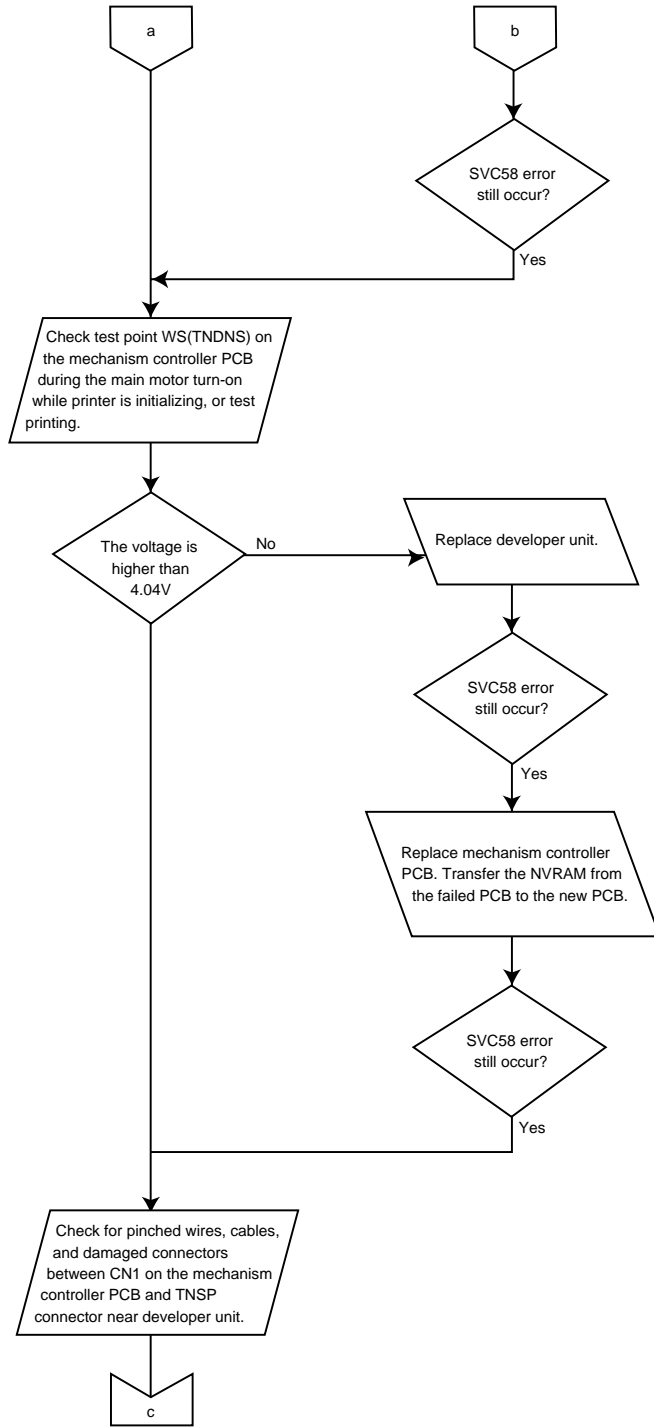

Figure 5-34. SVC58 Toner Low-density Alarm Flow Chart (2 of 3)

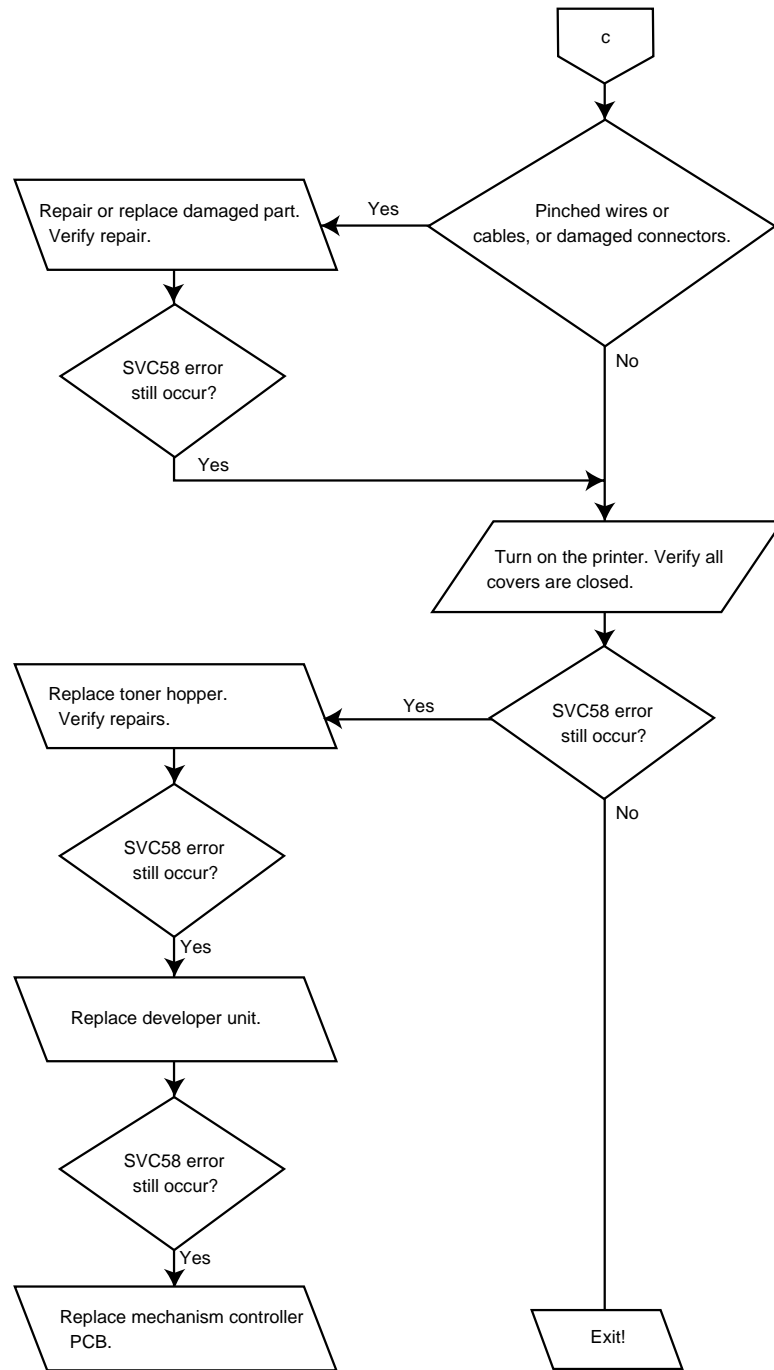

Figure 5-34. SVC58 Toner Low-density Alarm Flow Chart (3 of 3)

Reference Diagrams

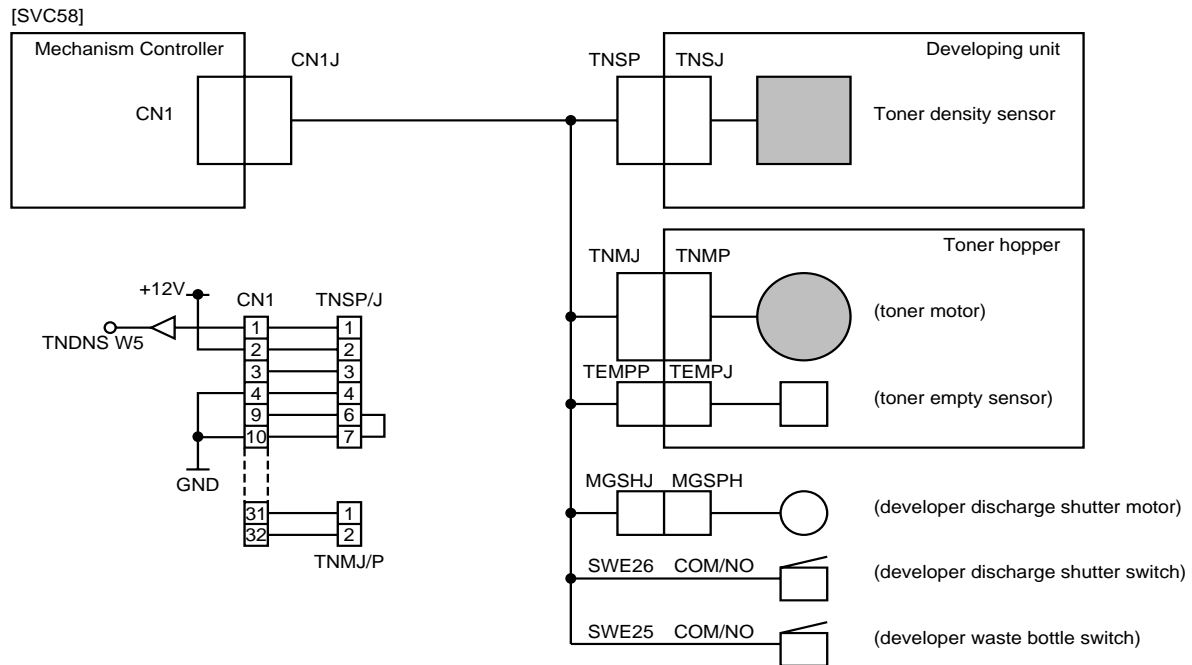

Figure 5-35. Toner Low-density Alarm (SVC58) Interconnections Diagram

5-2.18. SVC59 Reference Voltage Too-High Alarm

Explanation

After 500ms from the printer power was turned on (the +12V power was turned on), it was detected by the mechanism controller that the voltage (TDREF) of the reference voltage generation circuit in the mechanism controller was 1.45V or higher. (TDREF can not be measured directly.)

Troubleshooting Procedure

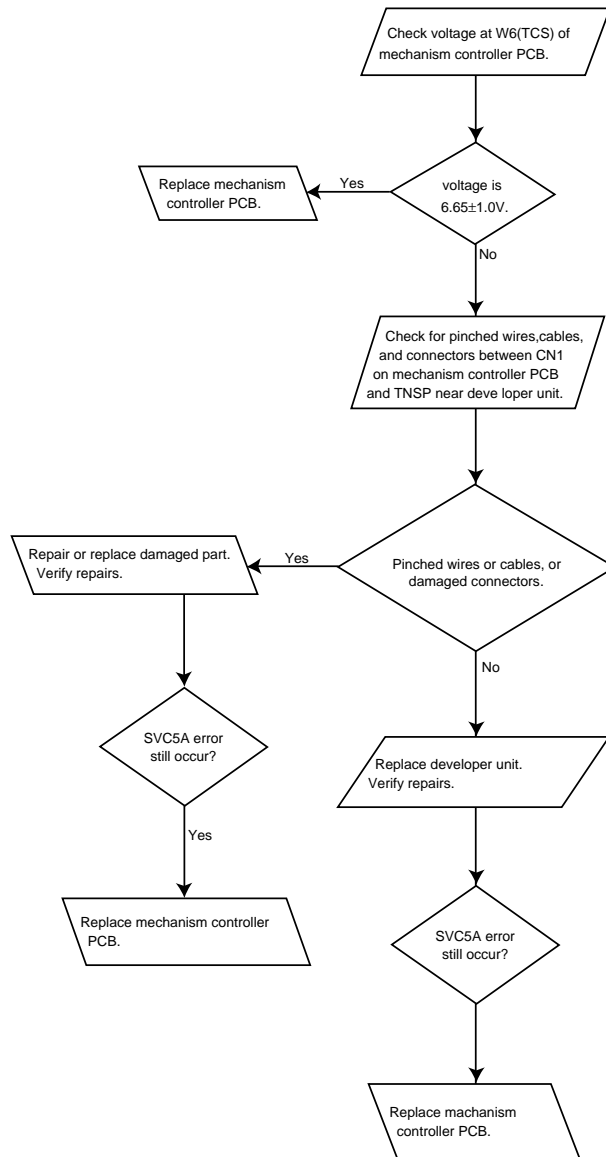

Figure 5-36. SVC59 Reference Voltage Too-High Alarm Flow Chart

Reference Diagrams

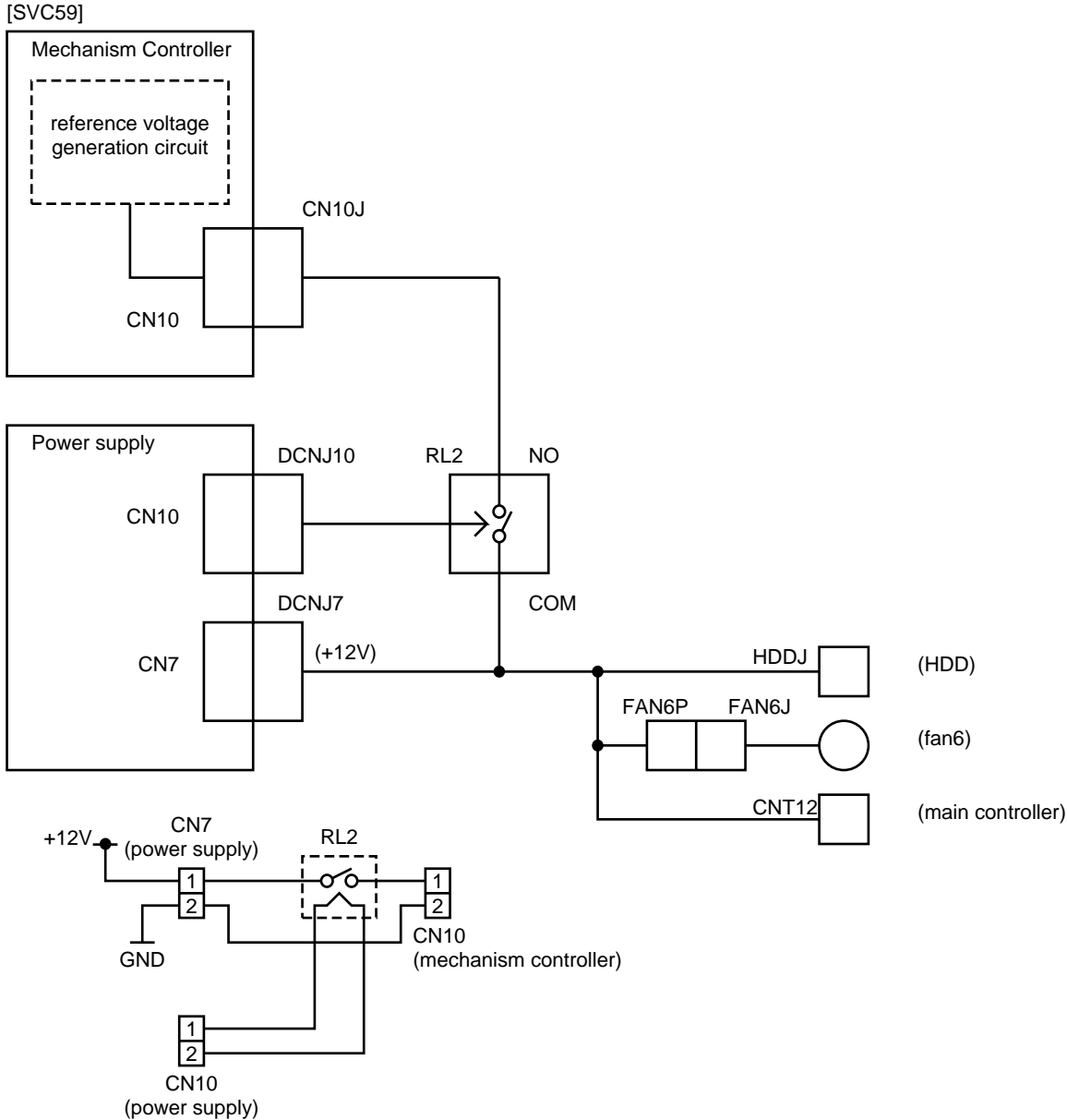

Figure 5-37. Reference Voltage Too-High Alarm (SVC59) Interconnections Diagram

5-2.19. SVC5A Reference Voltage Too-Low Alarm

Explanation

After 500ms from the printer power was turned on (the +12V power was turned on), it was detected by the mechanism controller that the voltage (TDREF) of the reference voltage generation circuit in the mechanism controller was 1.06V or lower. (TDREF can not be measured directly.)

Troubleshooting Procedure

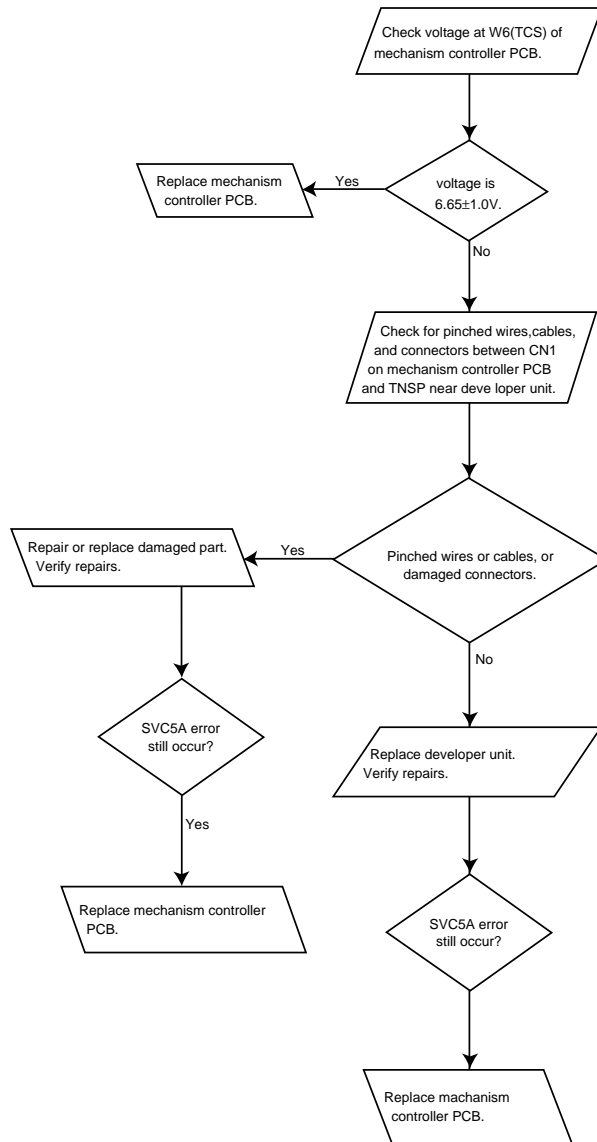

Figure 5-38. SVC5A Reference Voltage Too-Low Alarm Flow Chart

Reference Diagrams

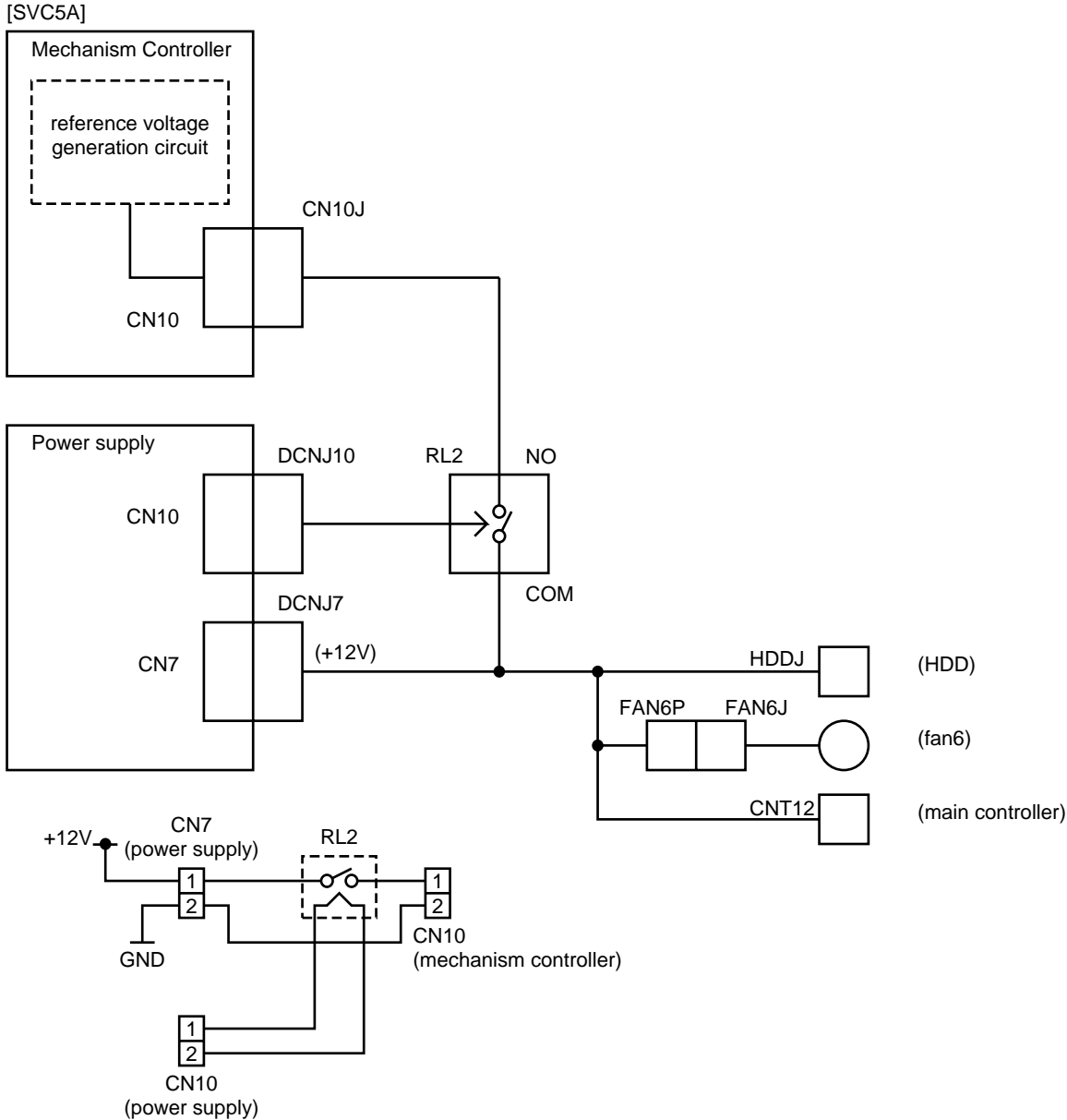

Figure 5-39. Reference Voltage Too-Low Alarm (SVC5A) Interconnections Diagram

5-2.20. SVC5B Toner Hopper Alarm

Explanation

The toner density low was detected from the toner density sensor in the developing unit by the mechanism controller unless the toner being detected from the toner empty sensor in the toner hopper.

Troubleshooting Procedure

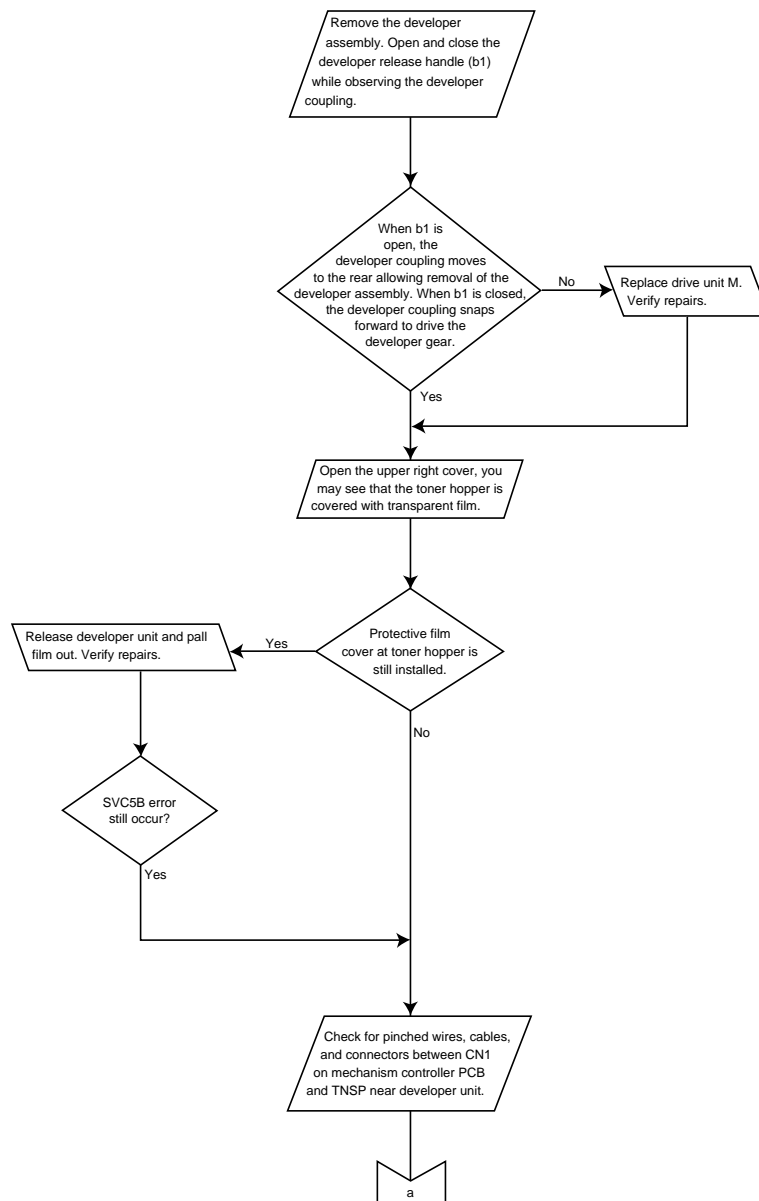

Figure 5-40. SVC5B Toner Hopper Alarm Flow Chart (1 of 2)

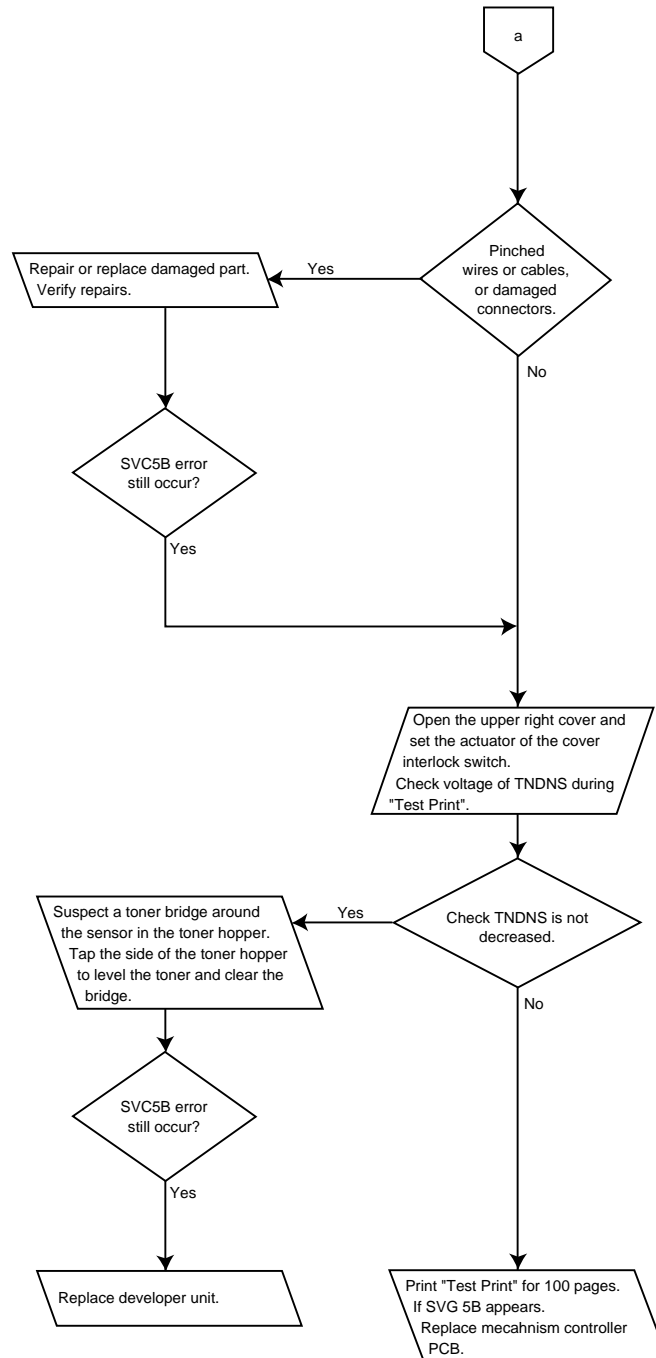

Figure 5-40. SVC5B Toner Hopper Alarm Flow Chart (2 of 2)

Reference Diagrams

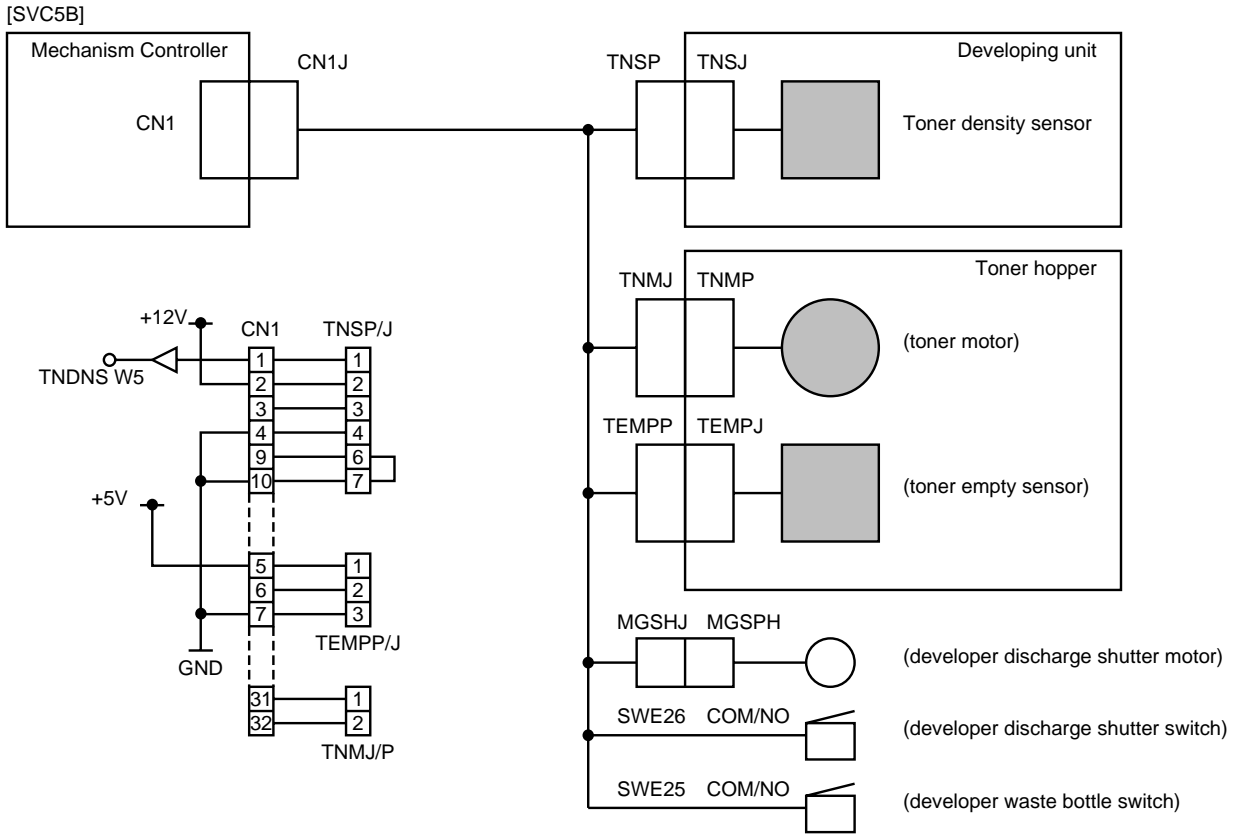

Figure 5-41. Toner Hopper Alarm (SVC5B) Interconnections Diagram

5-2.21. SVC69 Main Motor Alarm

Explanation

When 1 sec has passed after the main motor is turned on, check for the main motor is started. This check is executed every 1 ms until the main motor goes off. It was detected by the mechanism controller that the speed exceeds the range of 5% twice consecutively.

Troubleshooting Procedure

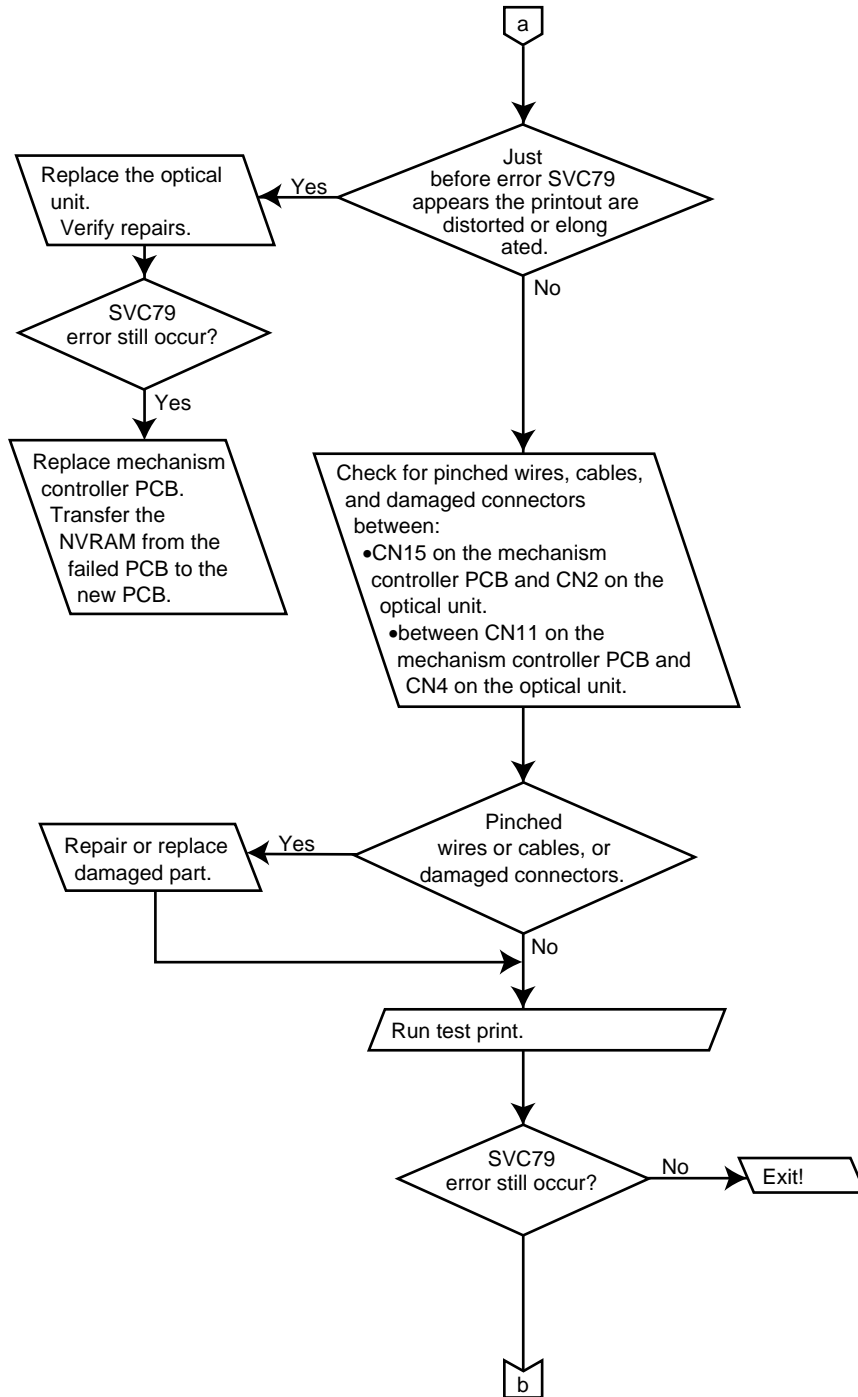

Figure 5-42. SVC69 Main Motor Alarm Flow Chart (1 of 3)

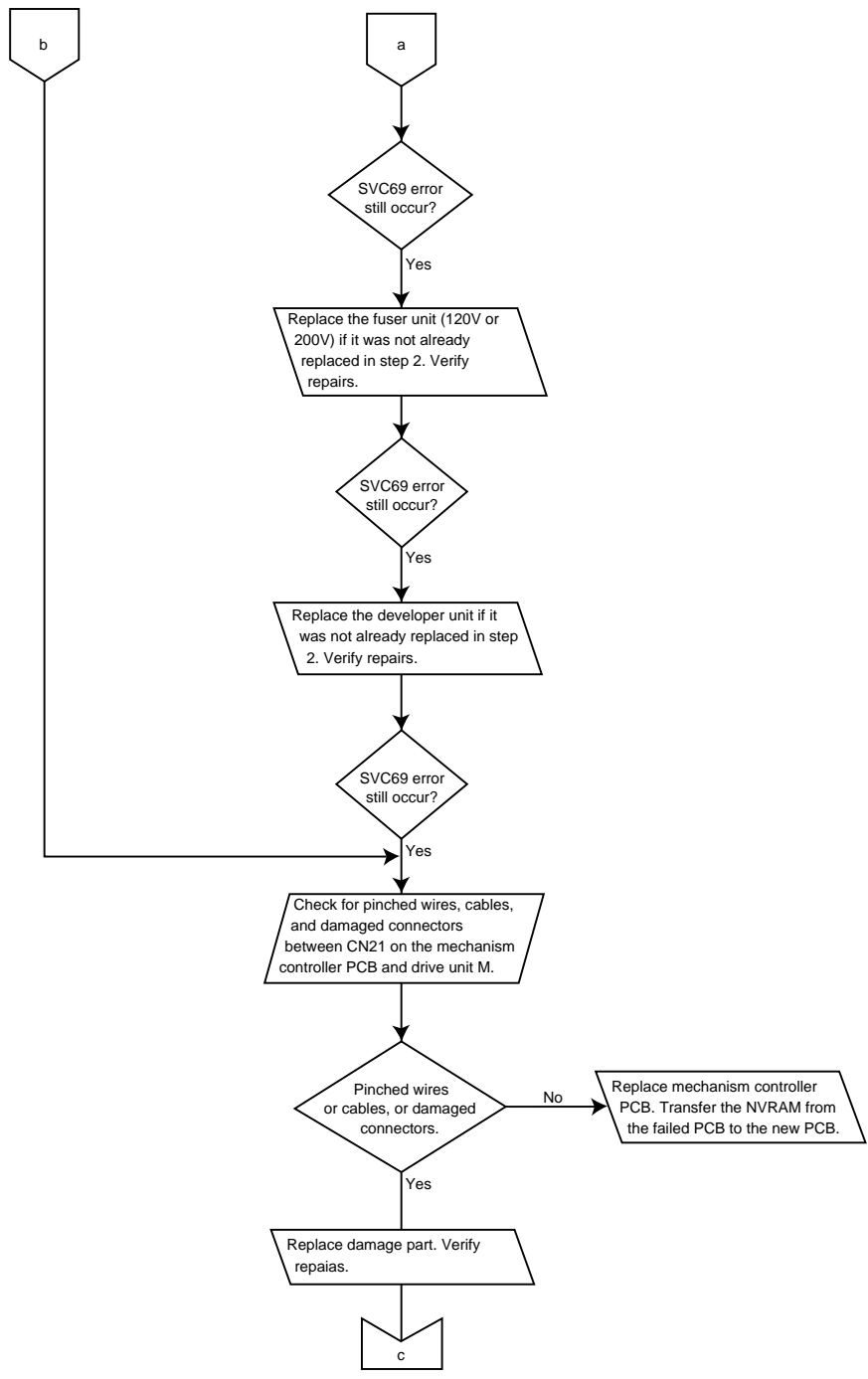

Figure 5-42. SVC69 Main Motor Alarm Flow Chart (2 of 3)

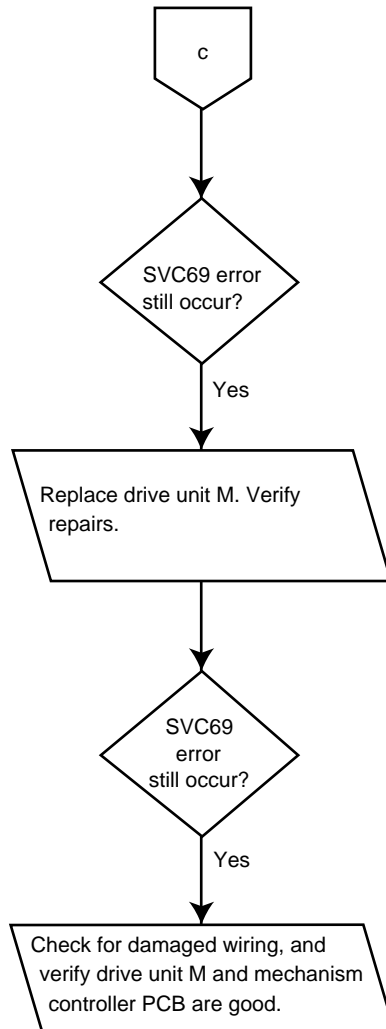

Figure 5-42. SVC69 Main Motor Alarm Flow Chart (3 of 3)

Reference Diagrams

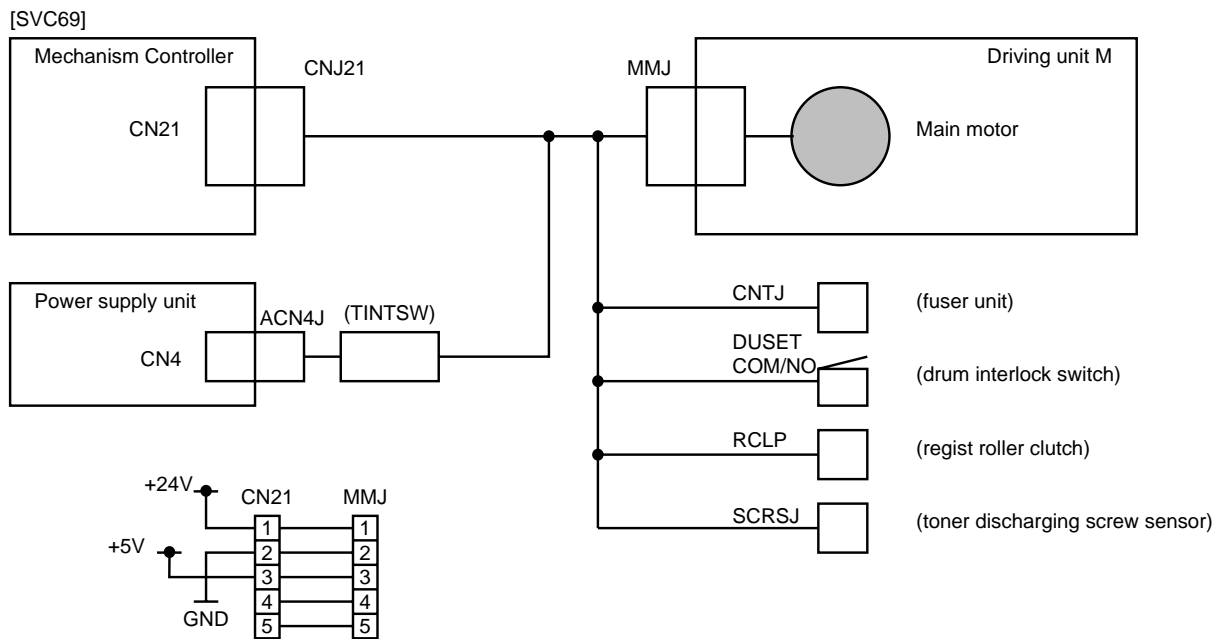

Figure 5-43. Main Motor Alarm (SVC69) Interconnections Diagram

5-2.22. SVC6F High Voltage Power Alarm**Explanation**

When high voltage power is on, overvoltage or overcurrent is checked every 5 ms. It was detected by the mechanism controller that the HVALM (high voltage alarm) signal goes on twice consecutively.

Troubleshooting Procedure

<010> Did this alarm occur during warming-up? (then cause of the alarm may at precharger in the drum unit or the developing unit, else at transfer charger) <Y:020, N:100>

<020> Disconnect the VB connector on the high voltage power supply PCB.

<030> Does this alarm still occur? <Y:032, N:040>

<032> Replace the drum unit.

<034> Does this alarm still occur? <Y:200, N:036>

<036> Connect VB as it was.

<Exit>

<040> Connect VB as it was, then clean the developing unit.

<050> Does this alarm still occur? <Y:052, N:Exit>

<052> Replace the developing unit.

<054> Does this alarm still occur? <Y:200, N:Exit>

<100> Clean the transfer charger.

<110> Does this alarm still occur? <Y:112, N:Exit>

<112> Replace the transfer charger.

<114> Does this alarm still occur? <Y:116, N:Exit>

<116> Remove and inspect the transfer unit. If there is unreparable damage on the transfer unit, replace the unit.

<118> Does this alarm still occur? <Y:250, N:Exit>

<200> Remove the rear cover, then check damages or pinches of wires, cables, and connector (-HV to the drum unit, VB to the developing unit).

<210> Does this alarm still occur? <Y:300, N:Exit>

<250> Remove the rear cover, then check damages or pinches of wires, cables, and connector (+HV and ACH to the transfer unit).

<260> Does this alarm still occur? <Y:300, N:Exit>

<300> Check damages or pinches of wires, cables, and connector (between CN3 on the power supply PCB and the CNDC on the high voltage power supply PCB, between CN16 on the mechanism controller PCB and CN1 on the high voltage power supply PCB).

<310> Does this alarm still occur? <Y:500, N:Exit>

<500> Replace the high voltage power supply PCB.

<510> Does this alarm still occur? <Y:520, N:Exit>

<520> Replace the mechanism controller PCB.

<Exit>

Troubleshooting Procedure

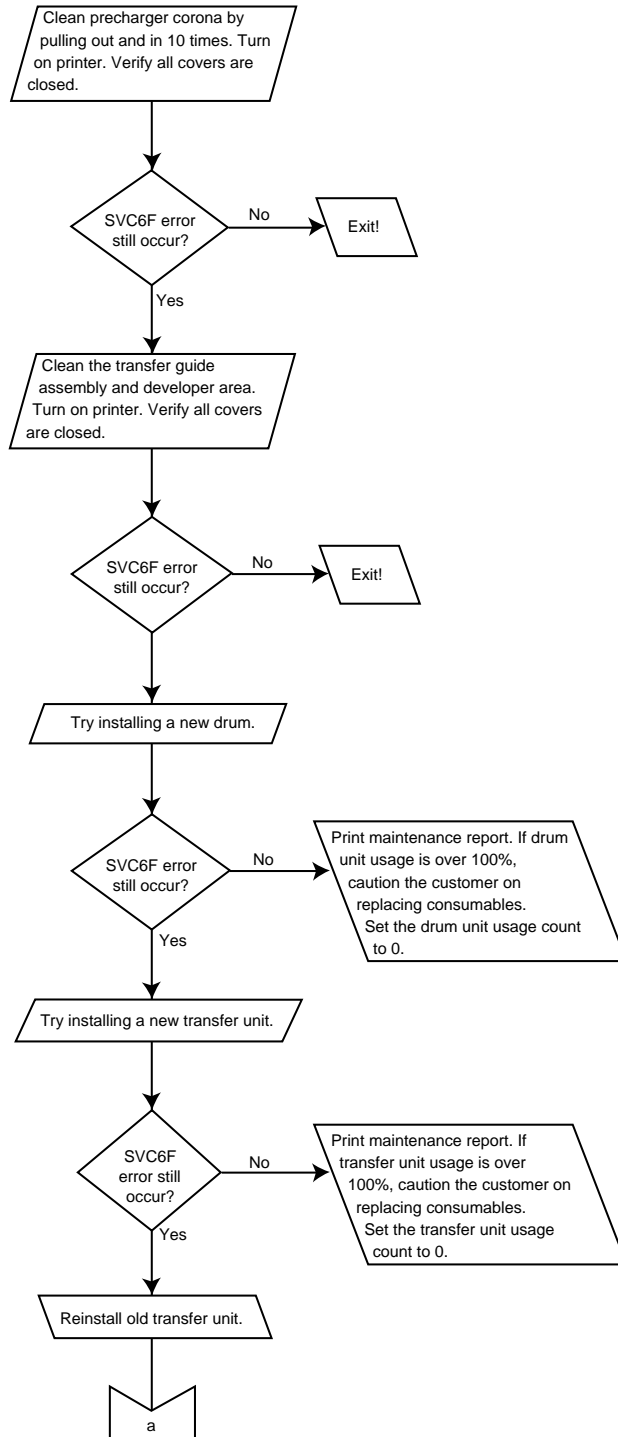

Figure 5-44. SVC6F High Voltage Power Alarm Flow Chart (1 of 3)

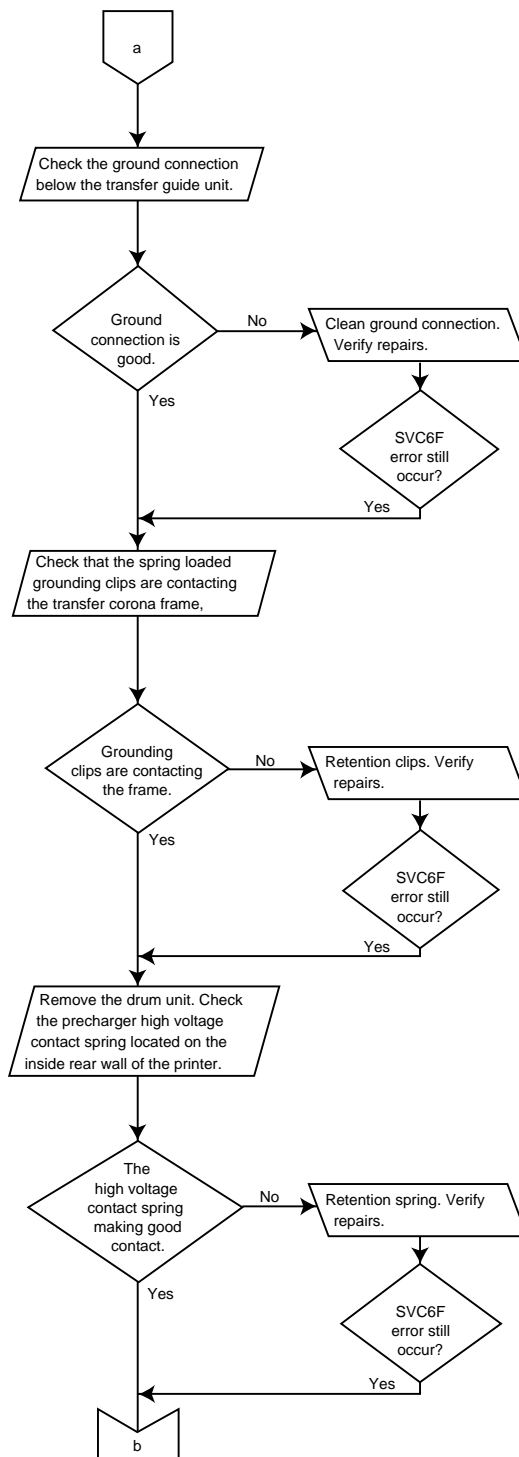

Figure 5-44. SVC6F High Voltage Power Alarm Flow Chart (2 of 3)

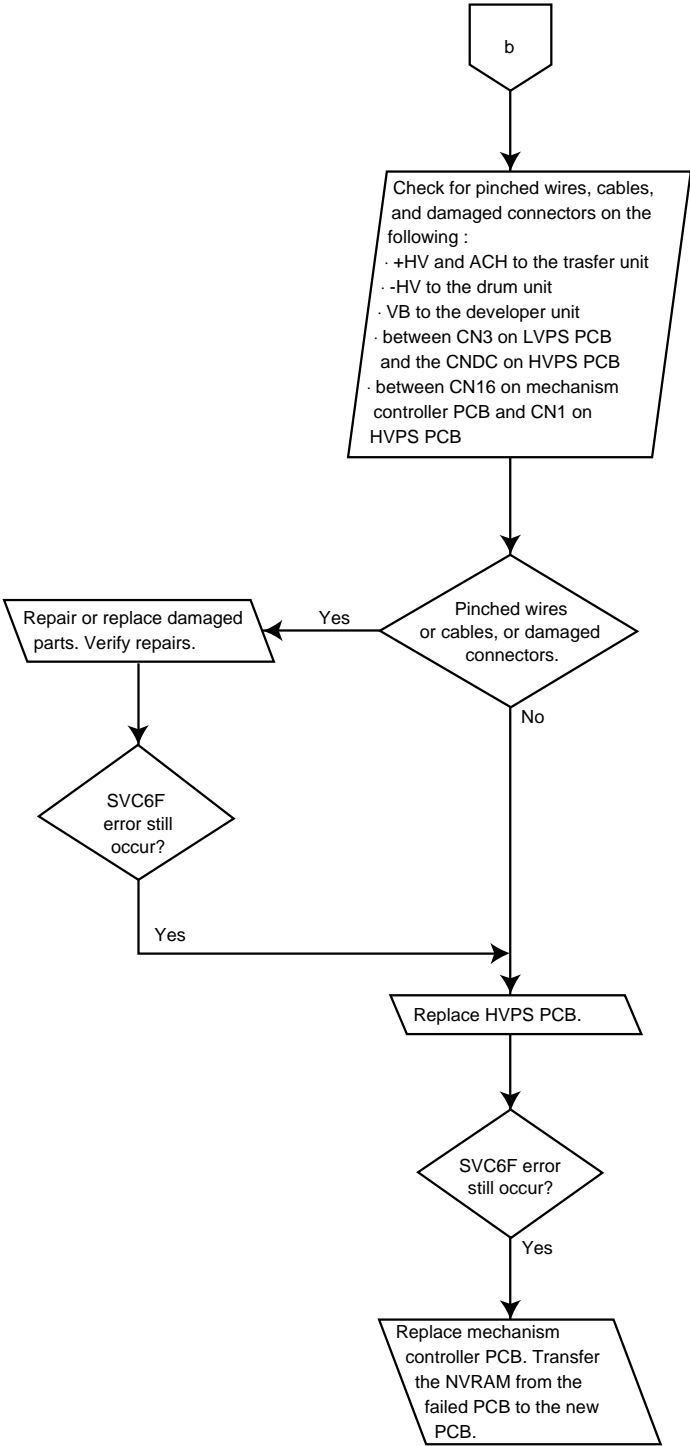
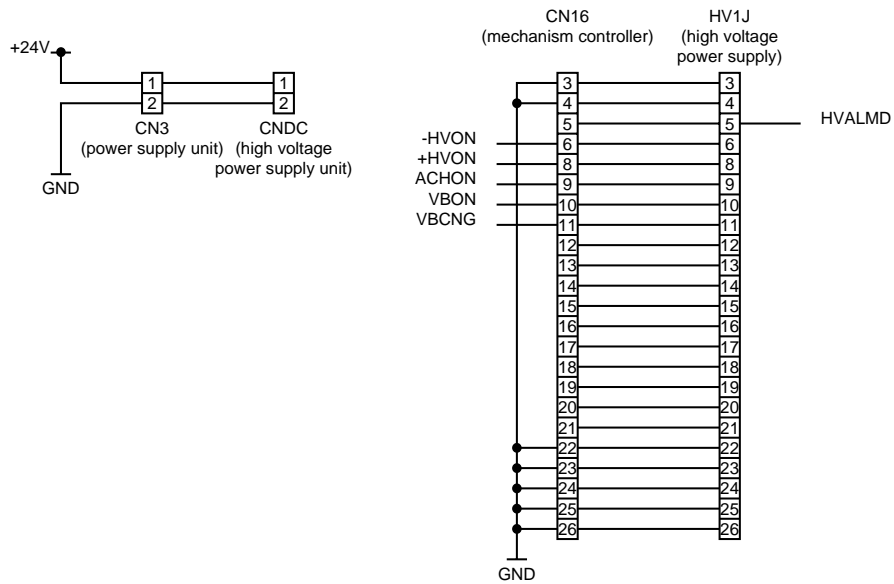
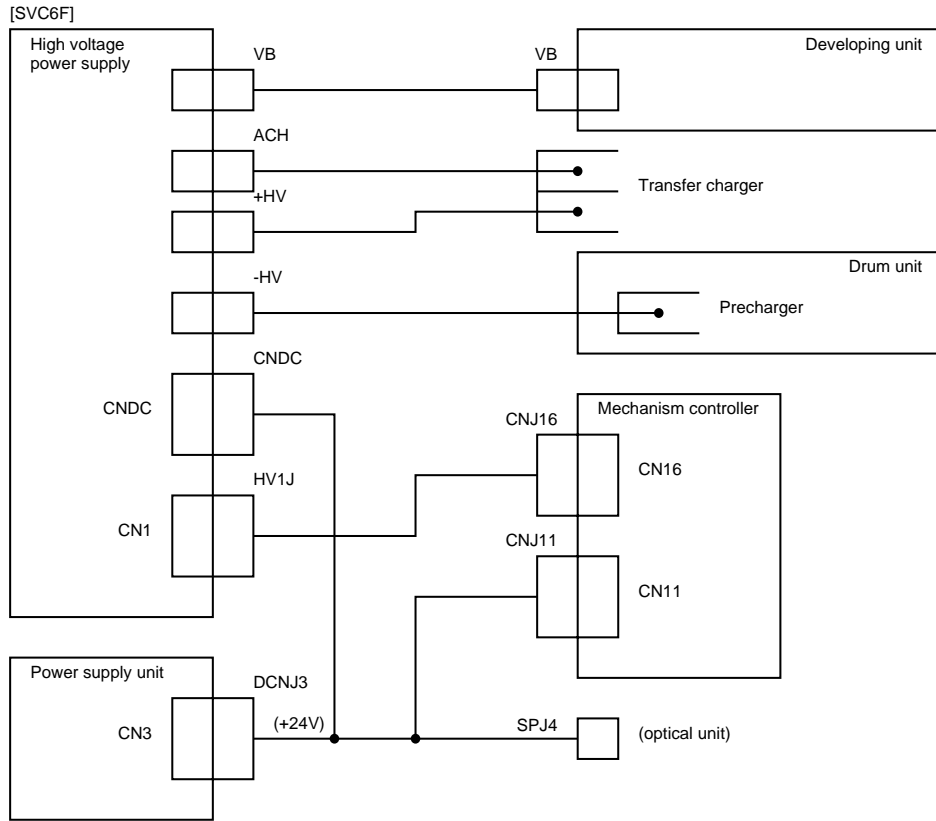

Figure 5-44. SVC6F High Voltage Power Alarm Flow Chart (3 of 3)

Reference Diagrams



High Voltage Power Alarm (SVC6F) Interconnections Diagram**5-2.23. SVC79 Spindle Motor Alarm****Explanation**

It was detected by the mechanism controller that the spindle motor in the optical unit did not start normally within 8 sec after the spindle was turned on. (The motor did not reach the range of 5% of the specified rotational frequency.)

Troubleshooting Procedure

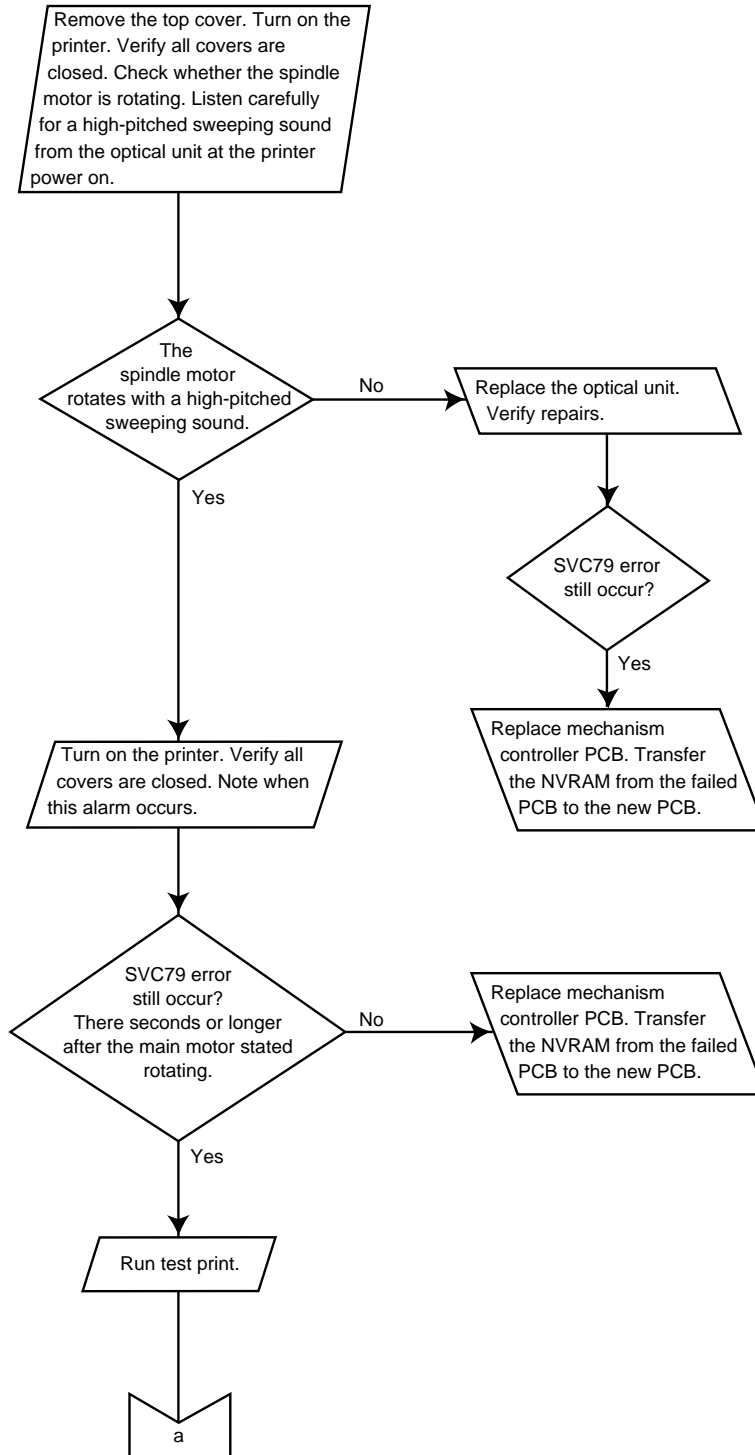

Figure 5-45. SVC79 Spindle Motor Alarm Flow Chart (1 of 3)

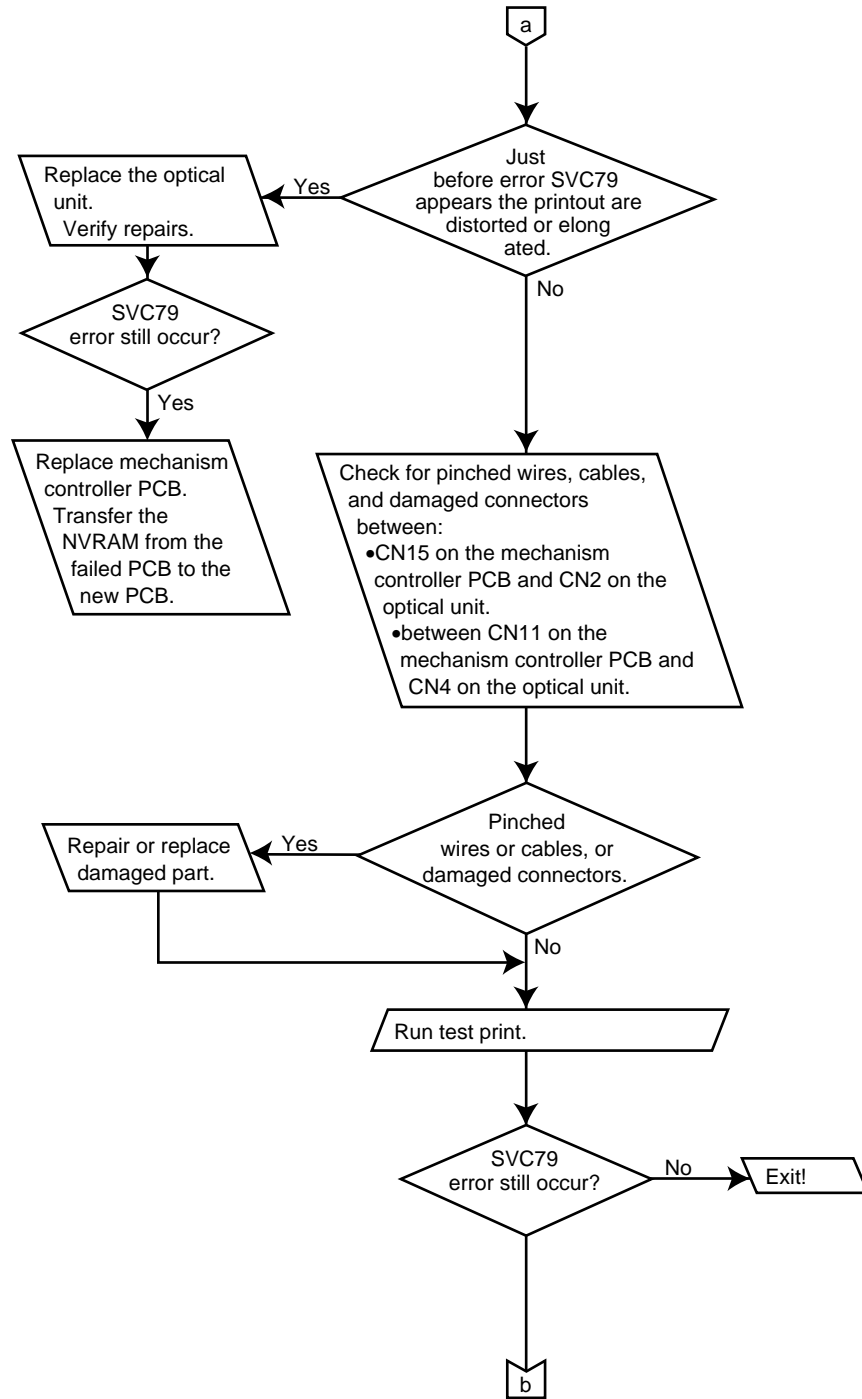

Figure 5-45. SVC79 Spindle Motor Alarm Flow Chart (2 of 3)

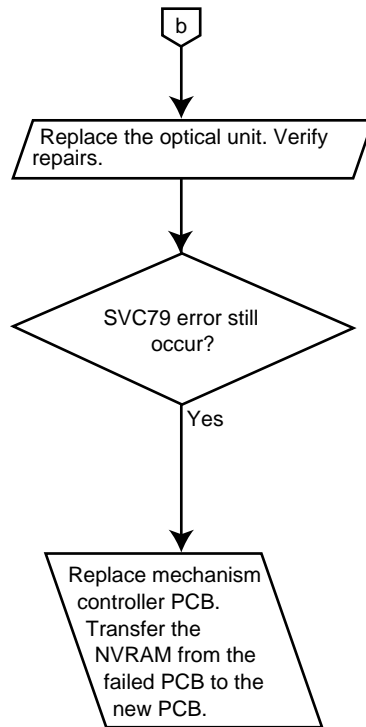

Figure 5-45. SVC79 Spindle Motor Alarm Flow Chart (3 of 3)

Reference Diagrams

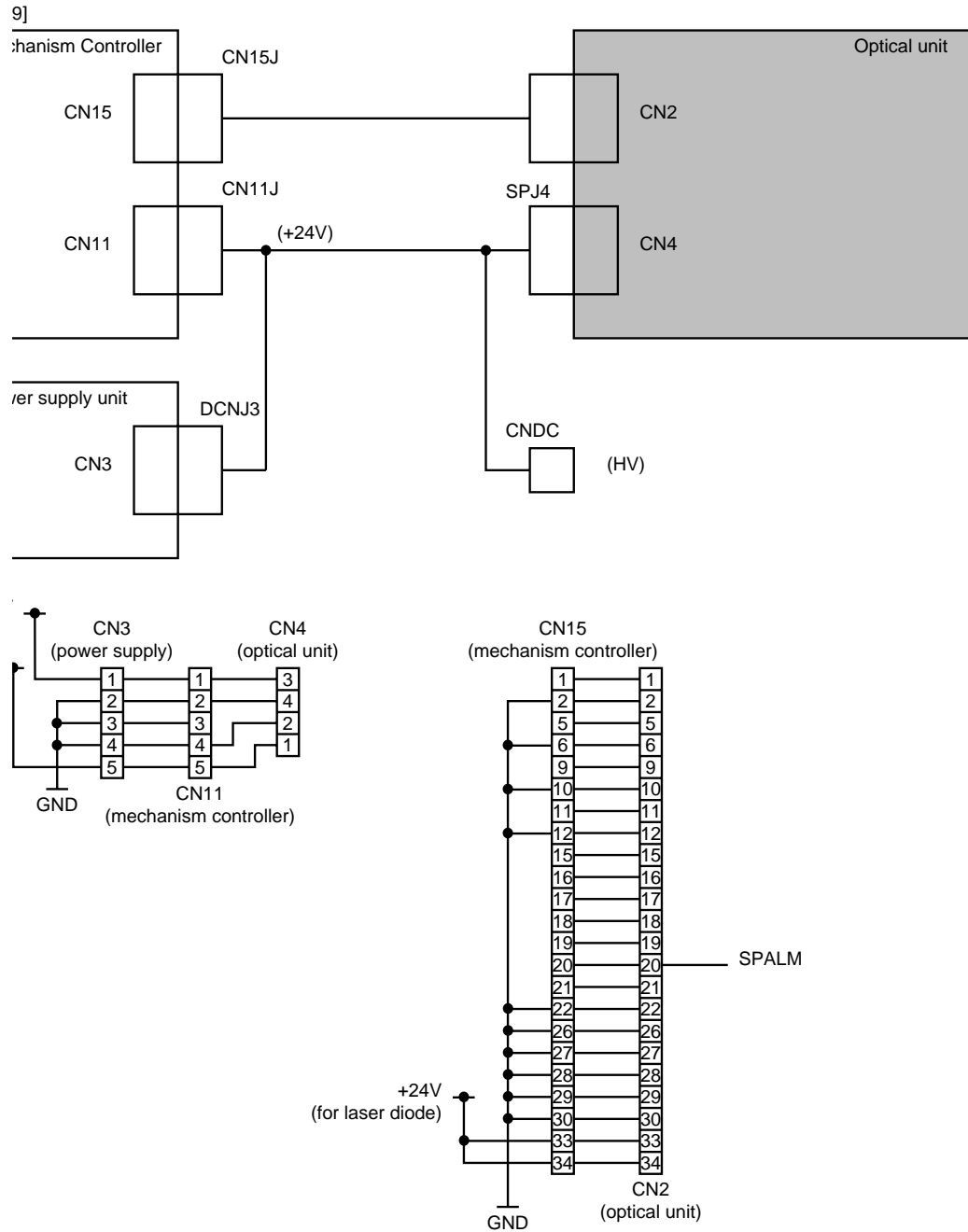

Figure 5-46. Spindle Motor Alarm (SVC79) Interconnections Diagram

5-2.24. SVC7A BD1 (Beam Detection) Alarm

Explanation

It was detected by the mechanism controller that the BDCAT (BD catch) is not ON after 50 ms passed from the LDENB (laser diode enable) signal was turned on.

(BD; beam detection = horizontal synchronous signal from the optical unit)

Troubleshooting Procedure

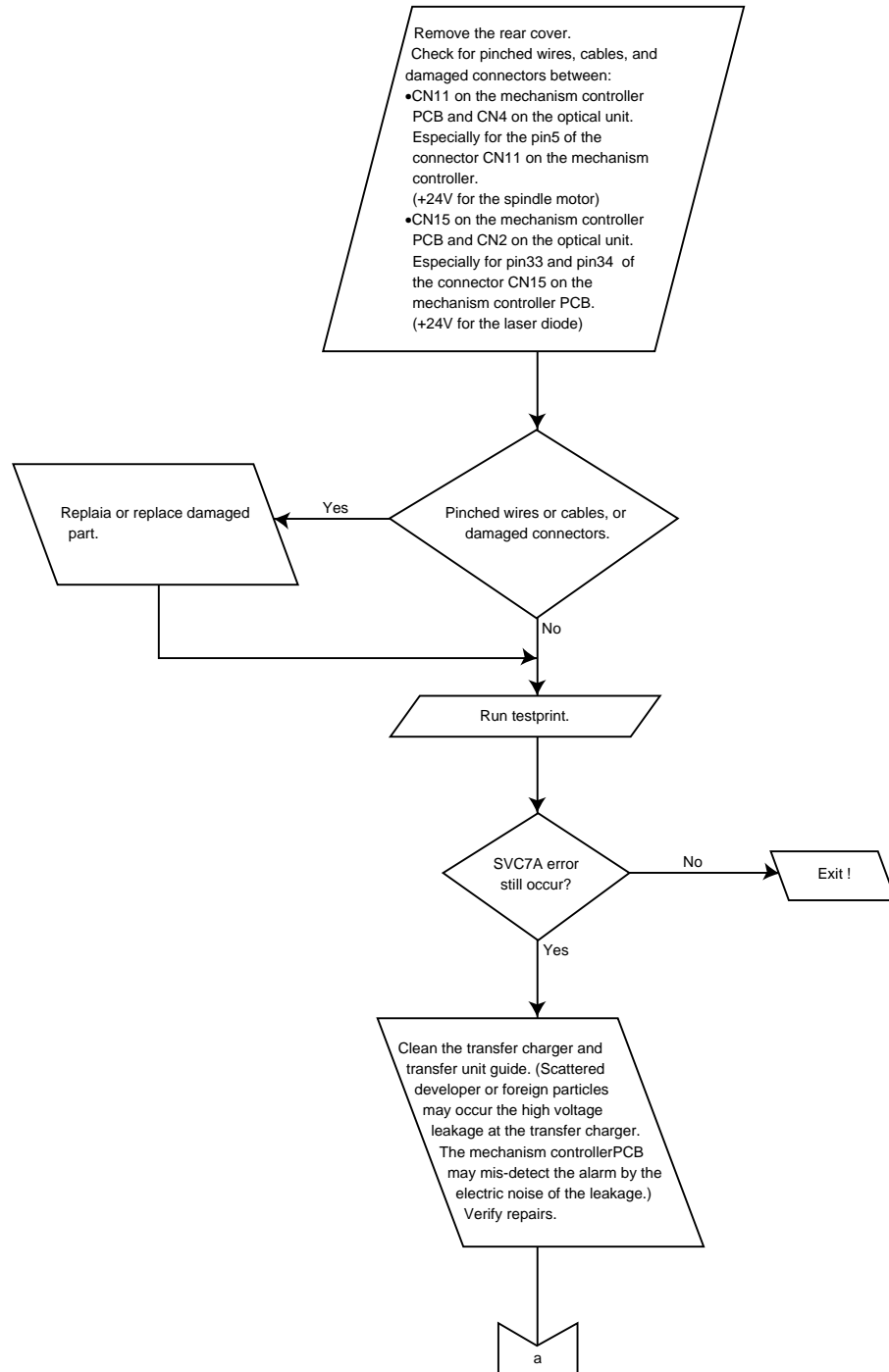

Figure 5-47. SVC7A BD1 (Beam Detection) Alarm Flow Chart (1 of 2)

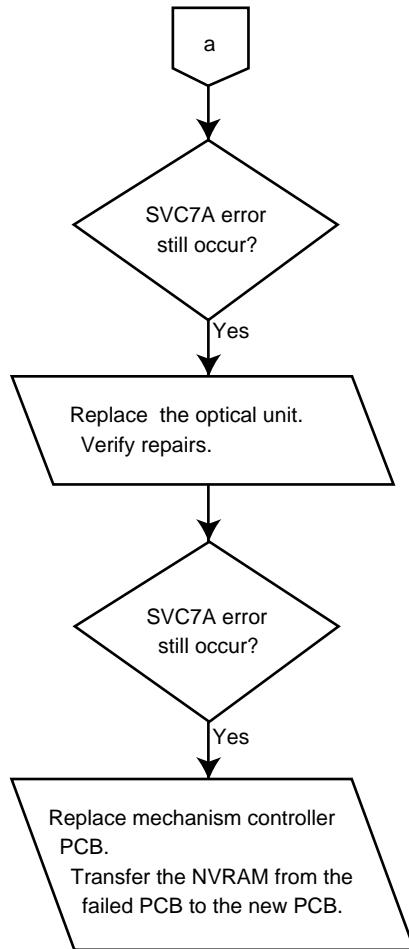

Figure 5-47. SVC7A BD1 (Beam Detection) Alarm Flow Chart (2 of 2)

Reference Diagrams

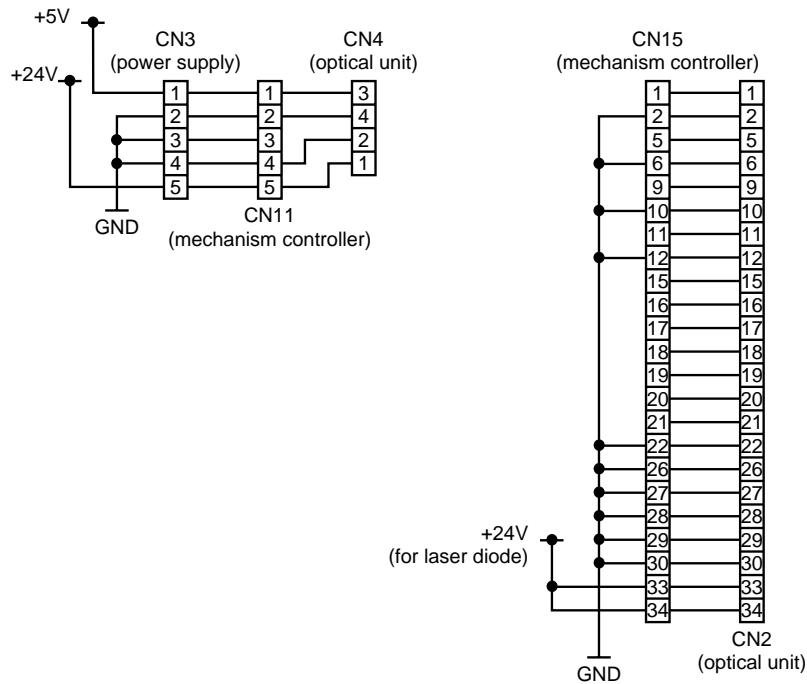
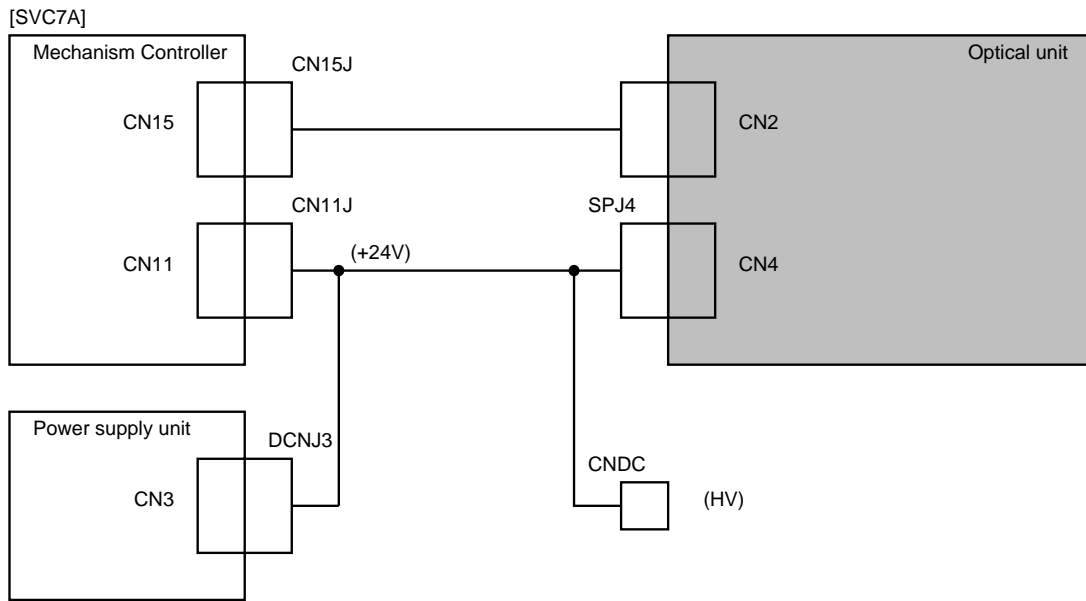

Figure 5-48. BD1 (Beam Detection) Alarm (SVC7A) Interconnections Diagram

5-2.25. SVC7B BD2 (Beam Detection) Alarm

Explanation

It was detected by the mechanism controller that the BD cycle time is not within the range of 1% of the specified value for 50 ms within 7 sec after the LDENB (laser diode enable) signal was turned on.

(BD; beam detection = horizontal synchronous signal from the optical unit)

Troubleshooting Procedure

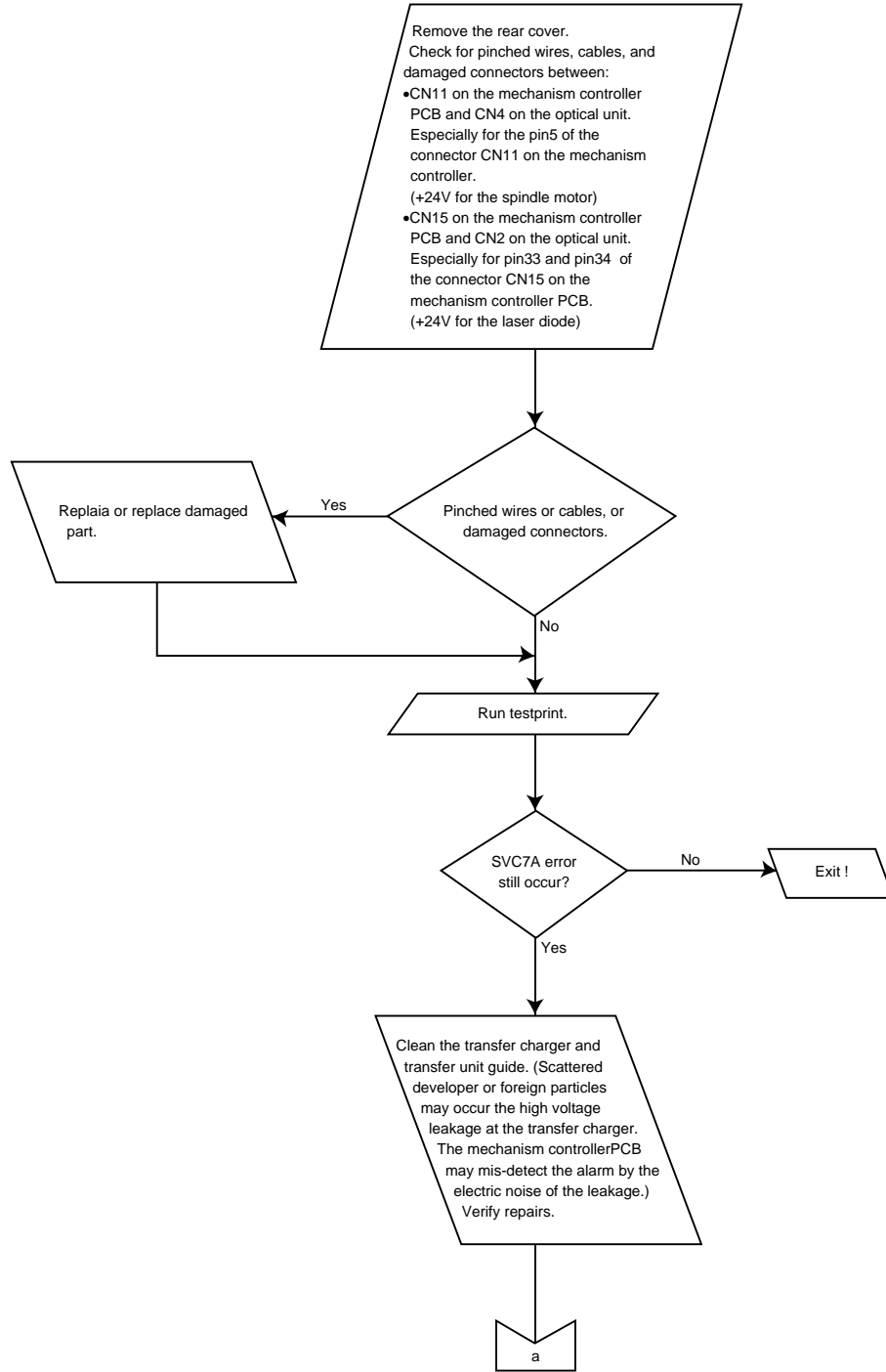

Figure 5-49. SVC7B BD2 (Beam Detection) Alarm Flow Chart (1 of 2)

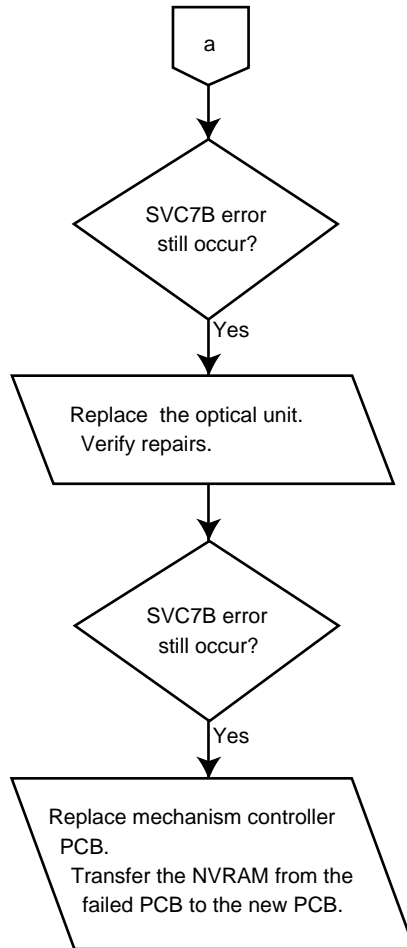

Figure 5-49. SVC7B BD2 (Beam Detection) Alarm Flow Chart (2 of 2)

Reference Diagrams

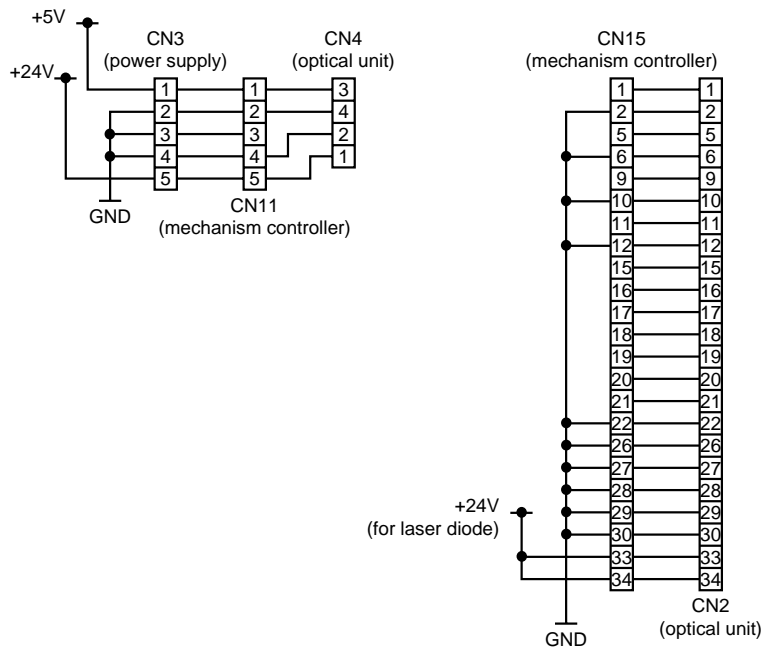
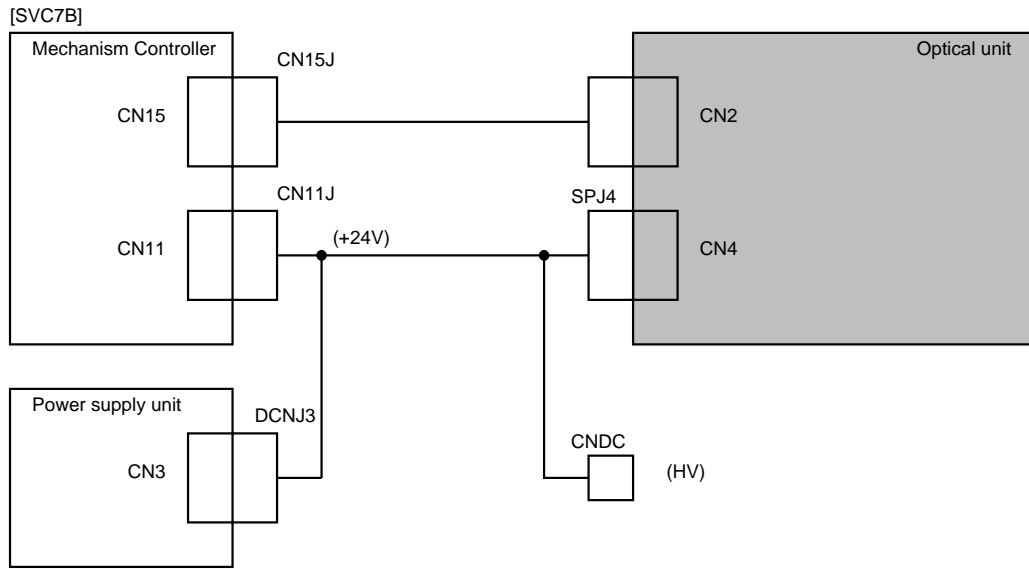

Figure 5-50. BD2 (Beam Detection) Alarm (SVC7B) Interconnections Diagram

5-2.26. SVC7C Beam Detection High-speed Alarm

Explanation

It was detected by the mechanism controller that the BD cycle time is -4% of the specified value or less. The BD cycle time is checked every scan.

(BD; beam detection = horizontal synchronous signal from the optical unit)

Troubleshooting Procedure

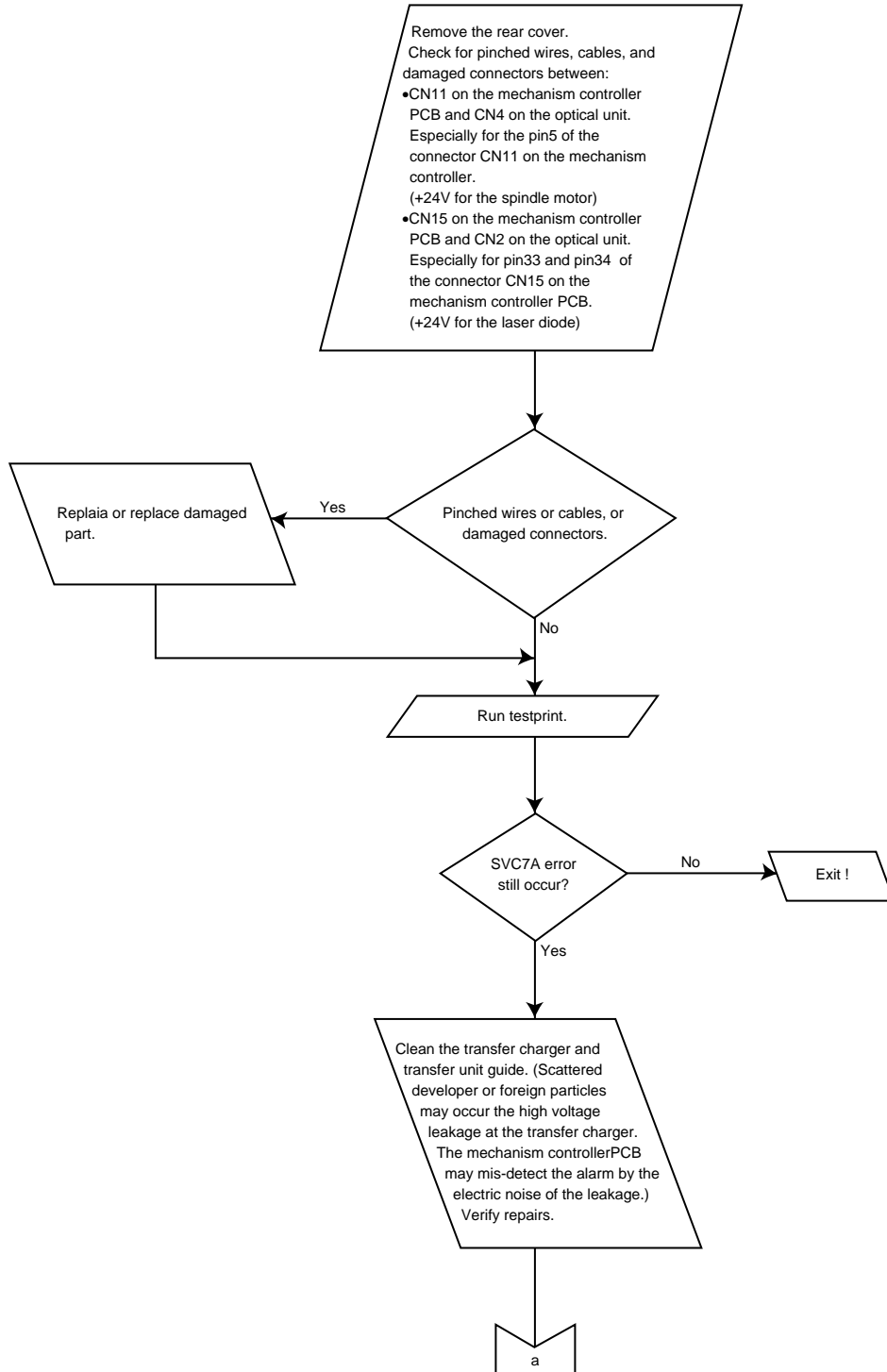

Figure 5-51. SVC7C Beam Detection High-speed Alarm Flow Chart (1 of 2)

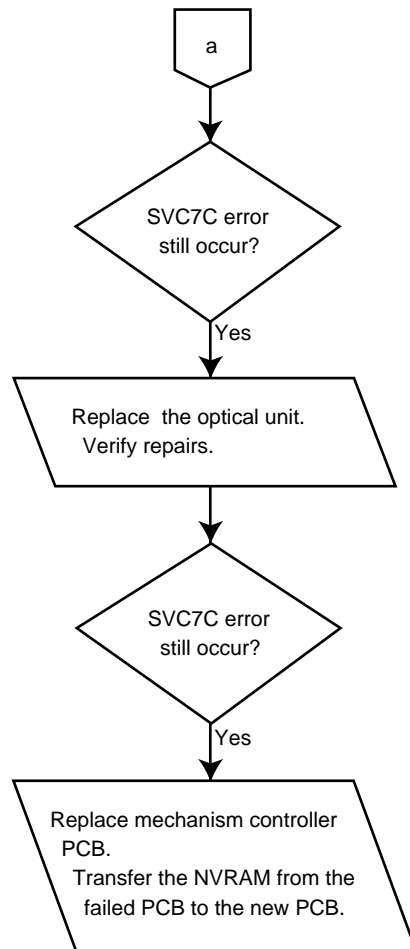

Figure 5-51. SVC7C Beam Detection High-speed Alarm Flow Chart (2 of 2)

Reference Diagrams

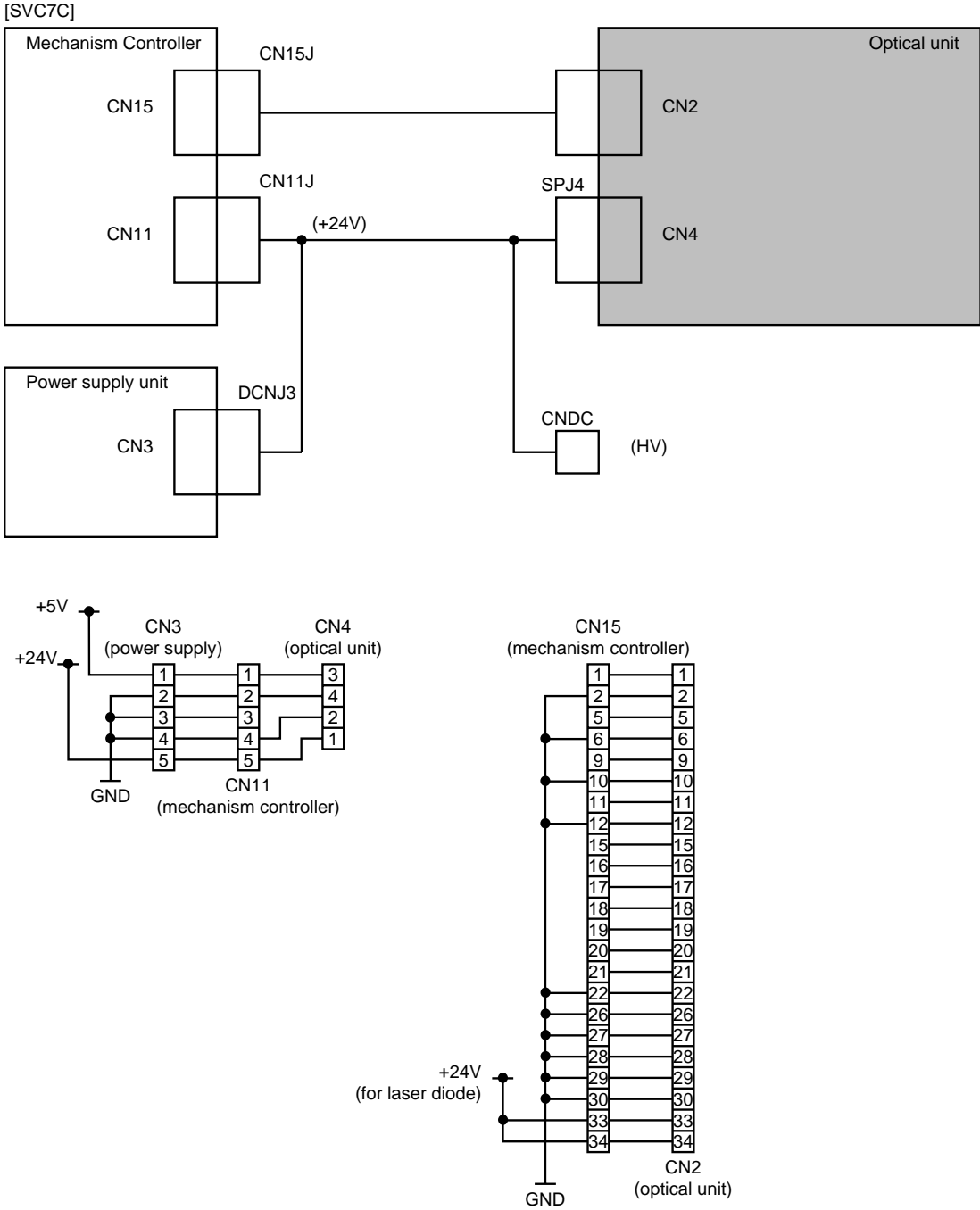

Figure 5-52. Beam Detection High-speed Alarm (SVC7C) Interconnections Diagram

5-2.27. SVC7D Beam Detection Low-speed Alarm

Explanation

It was detected by the mechanism controller that the BD cycle time is +4% of the specified value or less. The BD cycle time is checked every scan.

(BD; beam detection = horizontal synchronous signal from the optical unit)

Troubleshooting Procedure

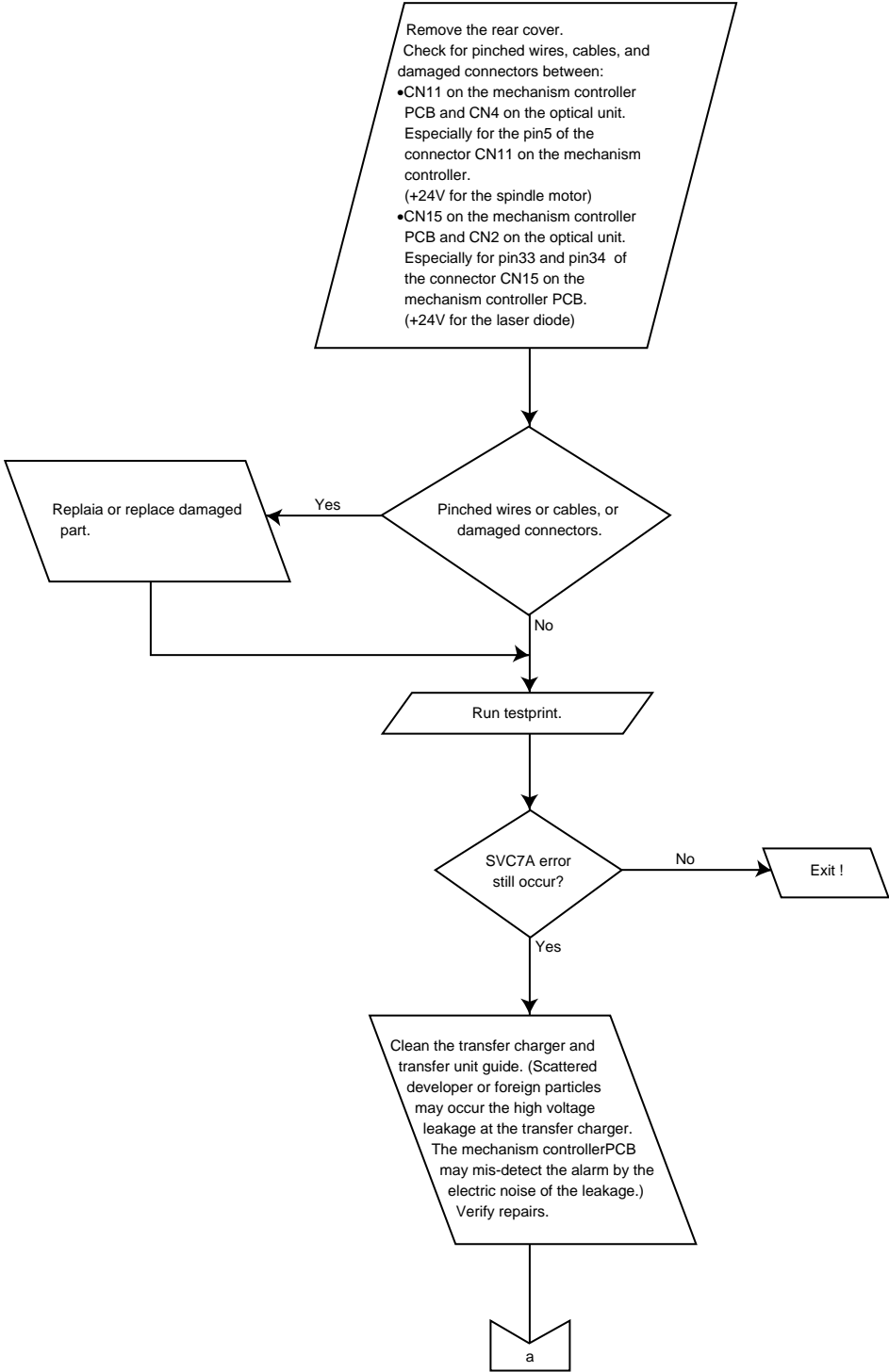

Figure 5-53. SVC7D Beam Detection Low-speed Alarm Flow Chart (1 of 2)

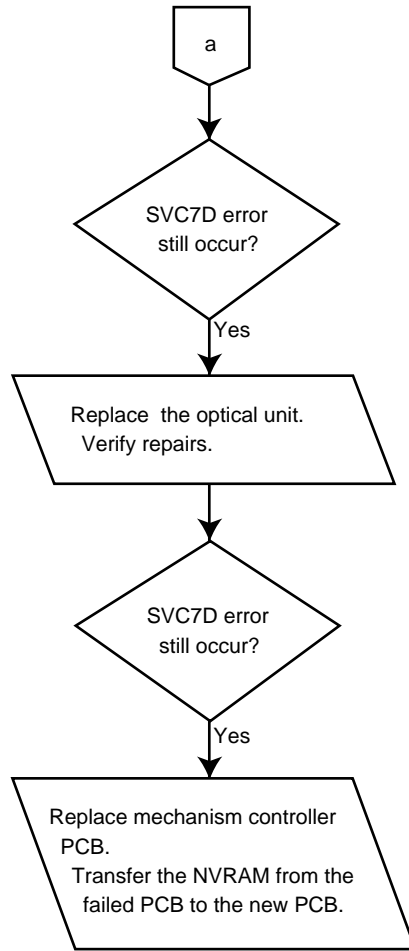

Figure 5-53. SVC7D Beam Detection Low-speed Alarm Flow Chart (2 of 2)

Reference Diagrams

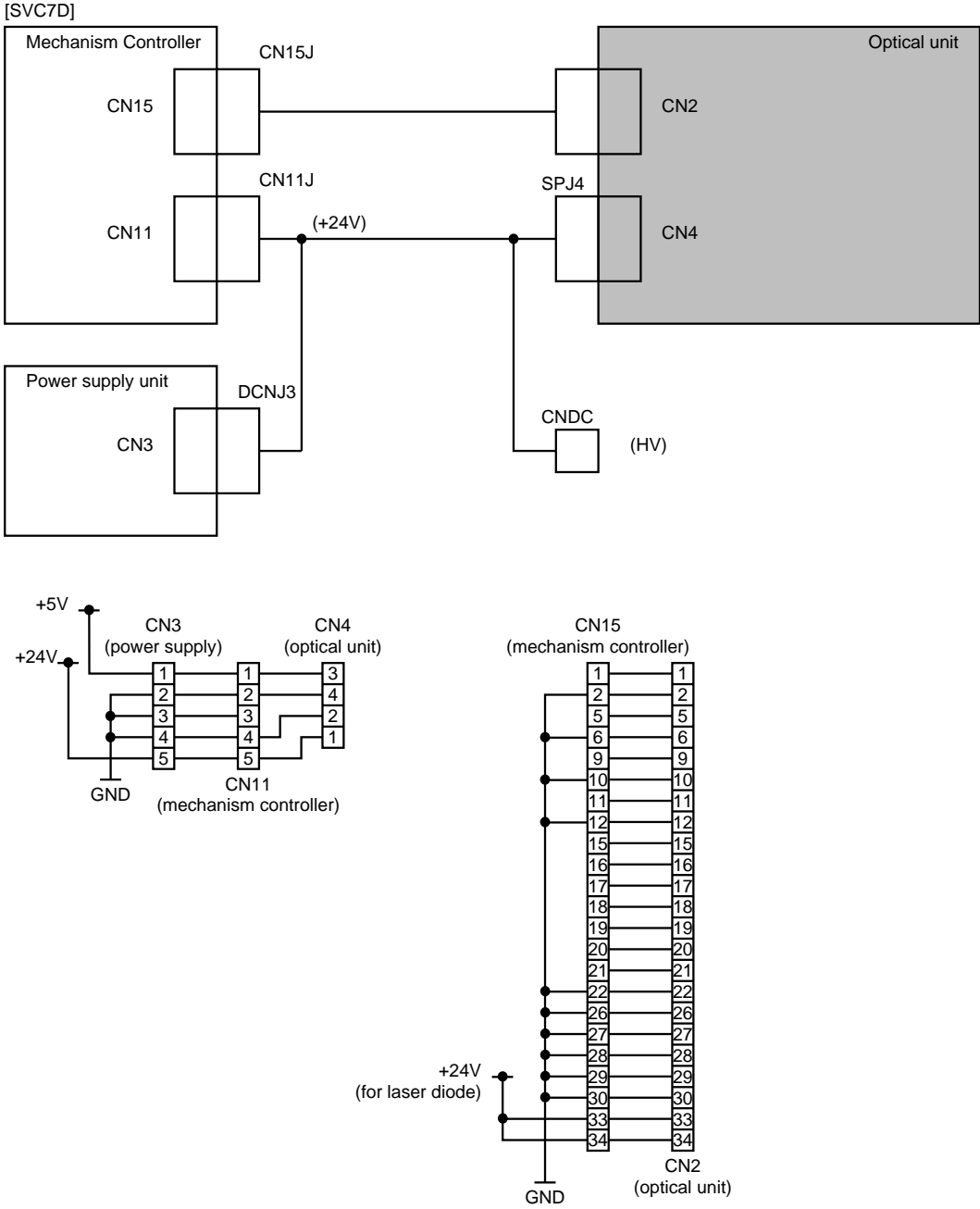

Figure 5-54. Beam Detection Low-speed Alarm (SVC7D) Interconnections Diagram

5-2.28. SVC7E Laser Diode (LD) Alarm

Explanation

It was reported by the optical unit to the mechanism controller that the BD signal from the second LD is not detected.

(BD; beam detection = horizontal synchronous signal, LD; laser diode)

Troubleshooting Procedure

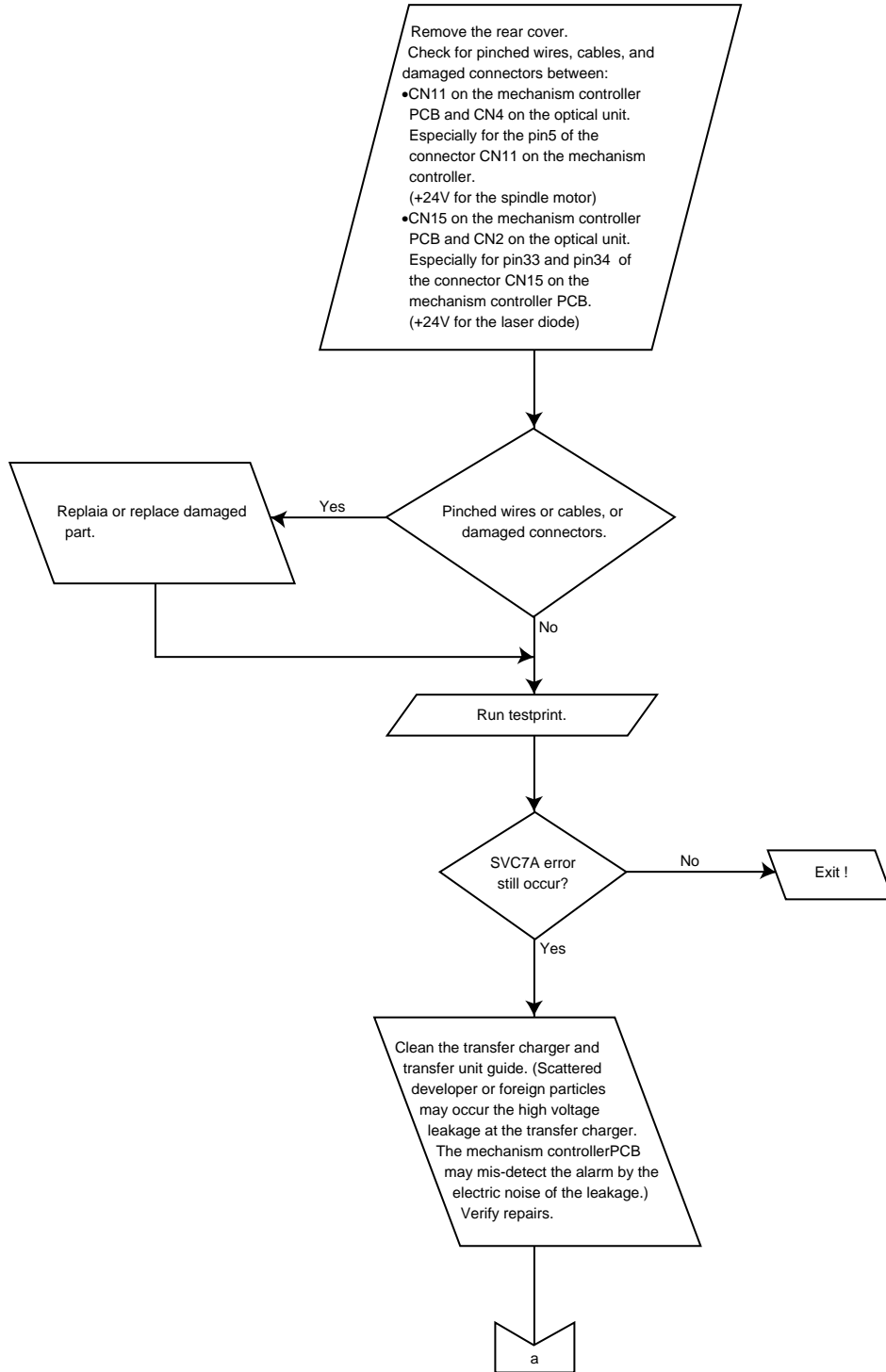

Figure 5-55. SVC7E Laser Diode (LD) Alarm Flow Chart (1 of 2)

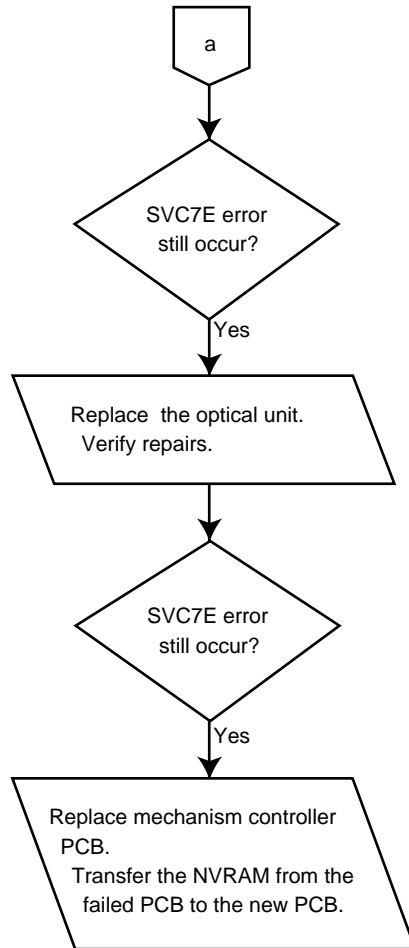

Figure 5-55. SVC7E Laser Diode (LD) Alarm Flow Chart (2 of 2)

Reference Diagrams

[SVC7E]

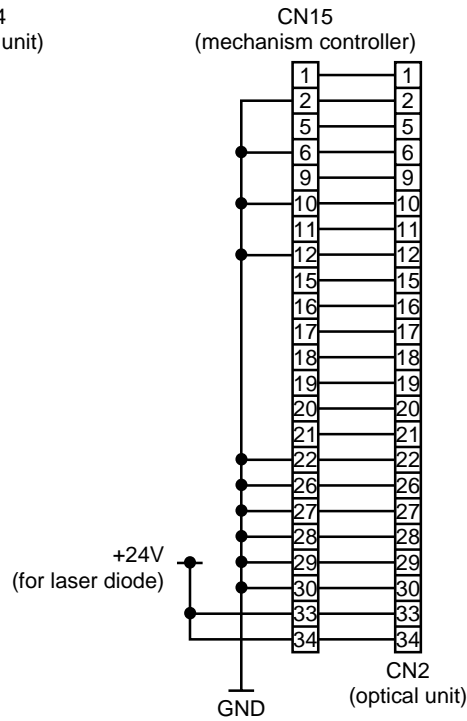
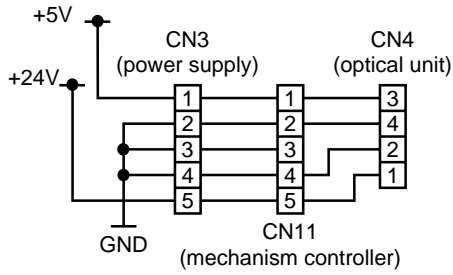
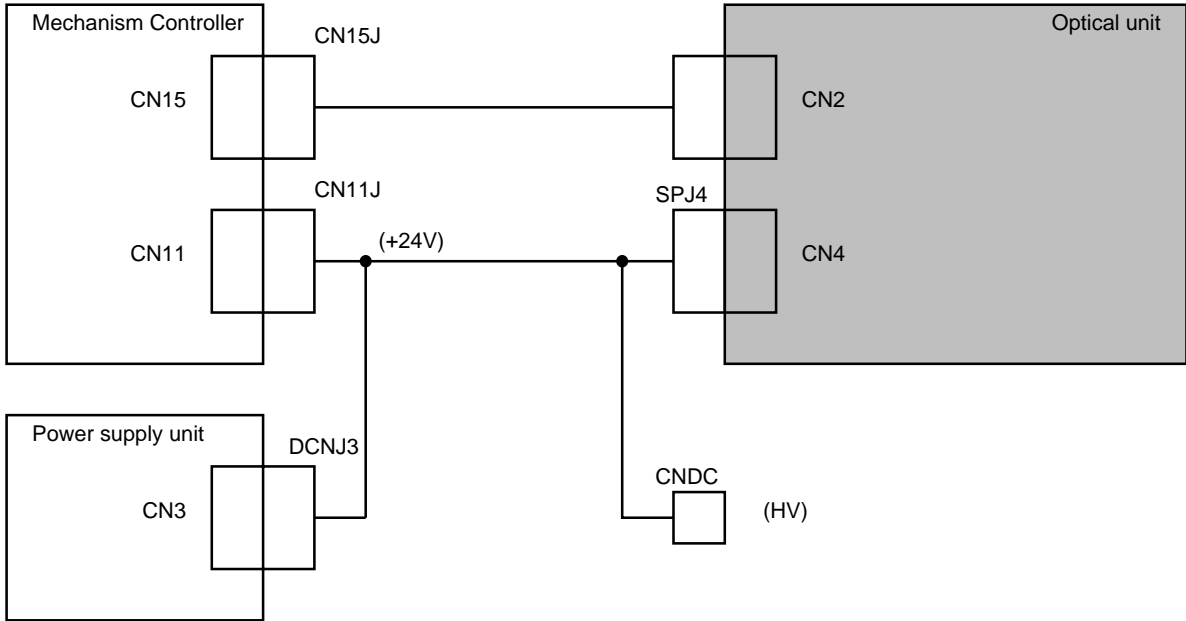

Figure 5-56. Laser Diode (LD) Alarm (SVC7E) Interconnections Diagram

5-2.29. SVCA0 Fan Alarm 1**Explanation**

It was detected by the mechanism controller that the fan 1 did not rotate. (fan 1: cooling fan in the optical unit, not visible from outside of the unit)

Troubleshooting Procedure

<010> Turn the printer on and open the front door, then check whether the air is flowing into the louver at upper left portion of the front face of the main frame. Is the air flowing into the louver? <Y:200, N:020>

<020> Does this error occur just after the printer being turned on? <Y:030, N:100>

<030> Remove the rear cover, then check the pin 5 and pin 6 of the connector CN11 on the mechanism controller PCB when the printer power is on (before the alarm occurs). Is the voltage 24V +/- 10% for both pins? <Y:100, N:032>

<032> Confirm all the covers and doors are closed. Then check the pin 9 of the connector CN9 (*PST2 signal) and the pin 4 of the connector CN8 (*PST1 signal) both on the mechanism controller PCB when the printer power is on (before the alarm occurs). Is the voltage 0V for both pins? <Y:034, N:220>

<034> Check damages or pinches of the wires, cables, and connector (between CN11 on the mechanism controller PCB and CN3 on the power supply PCB, between CN9 on the mechanism controller PCB and CN2 on the power supply PCB, between CN8 on the mechanism controller PCB and CN1 on the power supply PCB).

<036> Does this alarm still occur? <Y:040, N:Exit>

<040> Replace the power supply PCB.

<050> Exit

<100> Check damages or pinches of the wires, cables, and connector (between CN22 on the mechanism controller and FAN1P near at the optical unit).

<110> Does this alarm still occur? <Y:120, N:Exit>

<120> Replace the optical unit. (The fan 1 is in the optical unit, and it can not be replaced individually.)

<Exit>

<200> Check damages or pinches of the wires, cables, and connector (between CN22 on the mechanism controller and FAN1P near at the optical unit). Especially for the pin 3 of the connector FAN1P (alarm signal).

<210> Does this alarm still occur? <Y:220, N:Exit>

<220> Replace the mechanism controller PCB.

<Exit>

Caution

Do not bypass this error although you can do it by connect the pin 3 of the connector FAN1P to GND. It may cause damage on the optical unit.

Troubleshooting Procedure

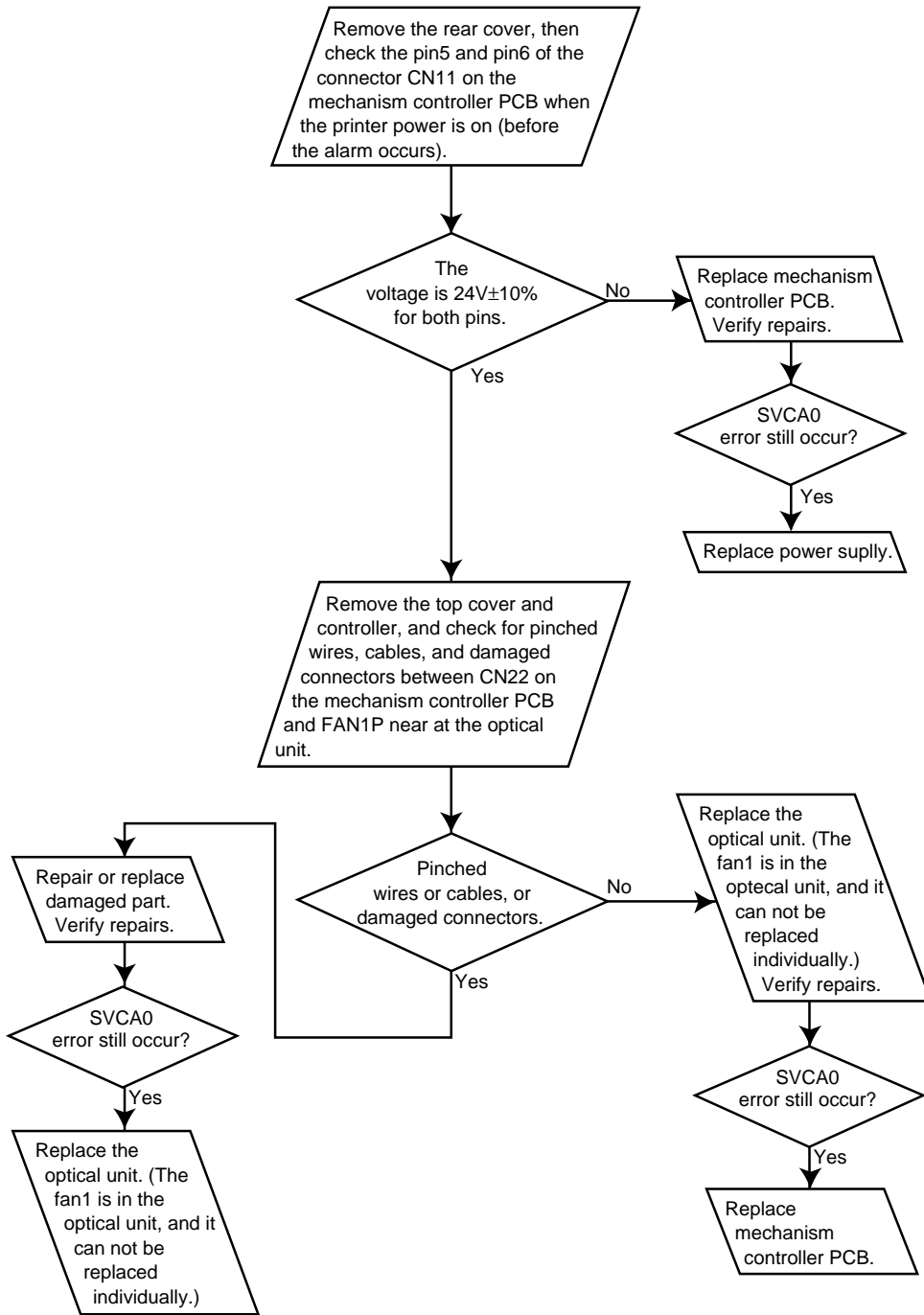

Figure 5-57. SVCA0 Fan Alarm 1 Flow Chart

Reference Diagrams

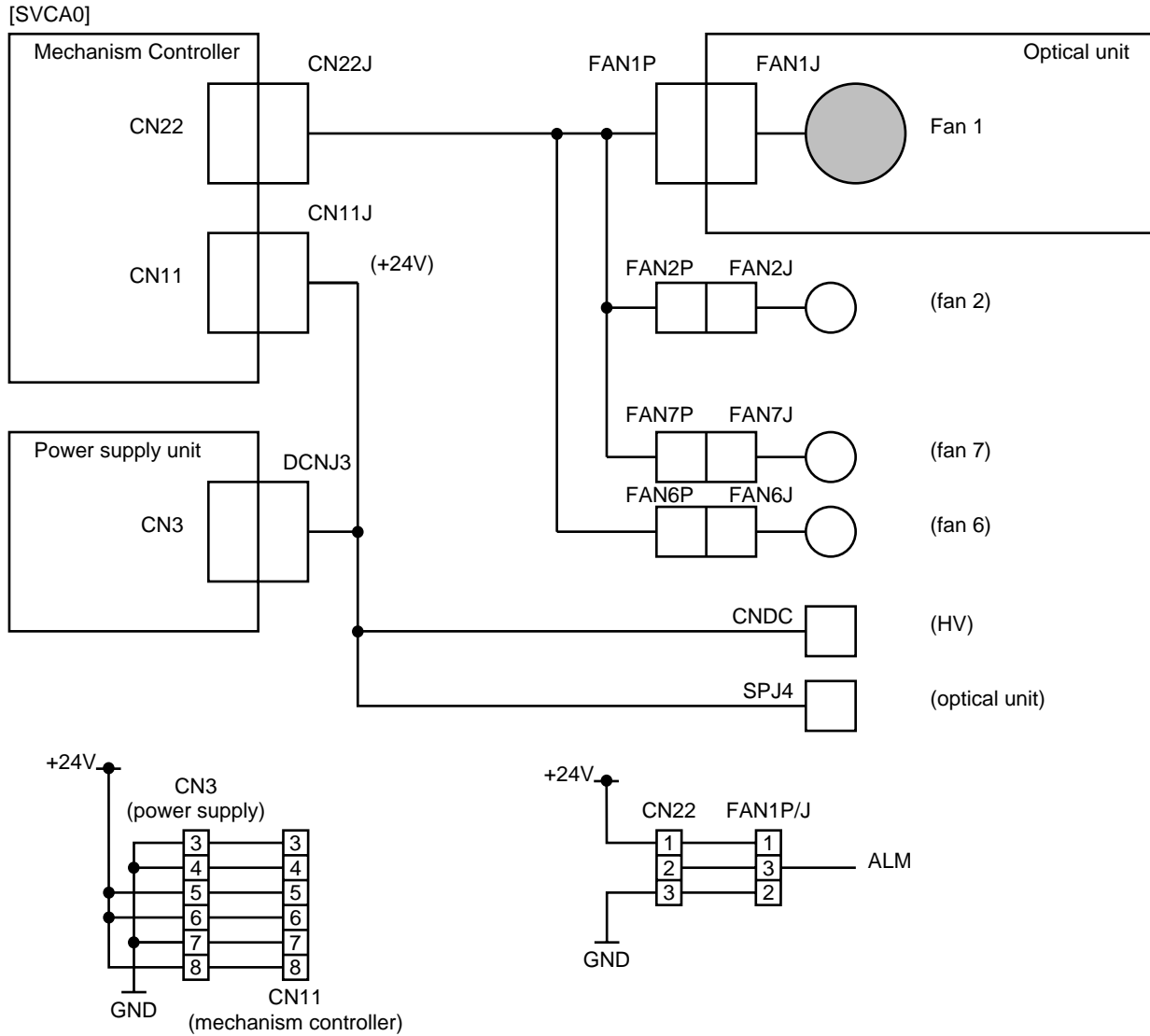

Figure 5-58. Fan Alarm 1 (SVCA0) Interconnections Diagram

5-2.0. SVCA1 Fan Alarm 2**Explanation**

It was detected by the mechanism controller that the fan 2 did not rotate. (fan 2: internal cooling fan at upper left of the rear side of the printer)

Troubleshooting Procedure

<010> Remove the rear cover, then check the fan during the printer power is on. Is the fan rotating? <Y:200, N:020>

<020> Is there something preventing the fan to rotate? <Y:022, N:030>

<022> Free the fan from anything preventing rotation.

<Exit>

<030> Check damages or pinches of the wires, cables, and connector (between CN22 on the mechanism controller PCB and FAN2P near the fan). Confirm the voltage between pin 1 and pin 2 of the connector FAN2P is approximate 24V.

<110> Does this error still occur? <Y:120, N:Exit>

<120> Replace the fan 2.

<Exit>

<200> Check damages or pinches of the wires, cables, and connector (between CN22 on the mechanism controller and FAN2P near at the optical unit). Especially for the pin 3 of the connector FAN2P (alarm signal).

<210> Does this alarm still occur? <Y:220, N:Exit>

<220> Replace the mechanism controller PCB.

<Exit>

Do not bypass this error although you can do it by connect the pin 3 of the connector FAN2P to GND. It may cause another print quality problems or damage on the developing unit.

Troubleshooting Procedure

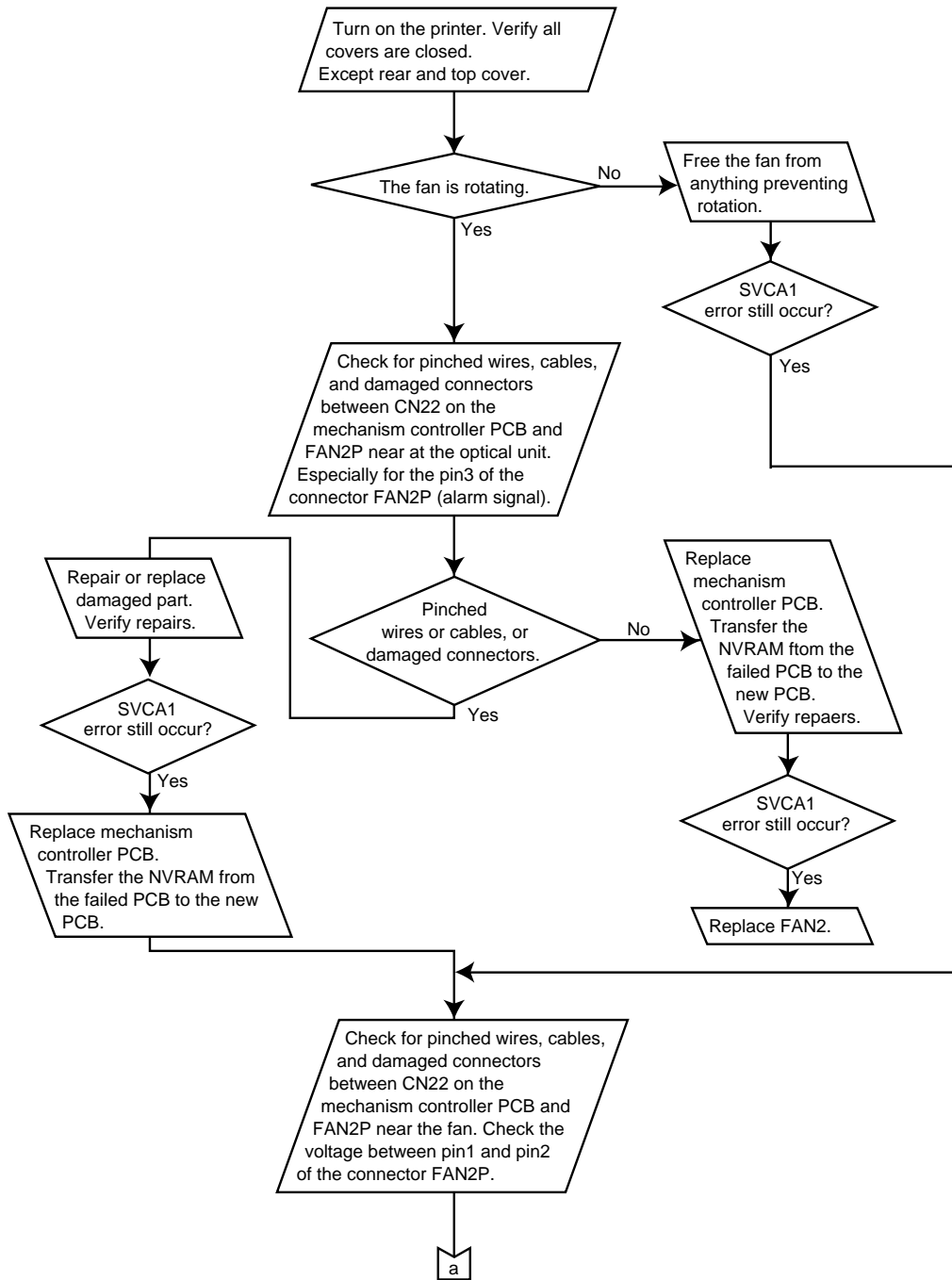

Figure 5-9. SVCA1 Fan Alarm 2 Flow Chart (1 of 2)

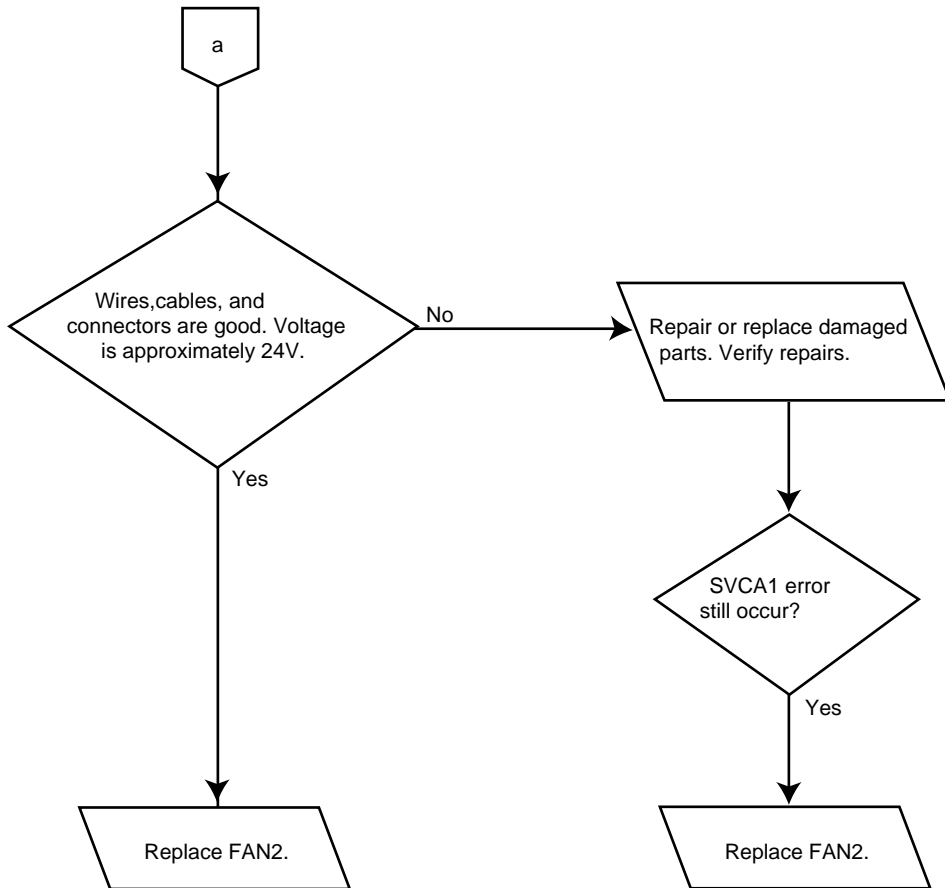

Figure 5-9. SVCA1 Fan Alarm 2 Flow Chart (2 of 2)

Reference Diagrams

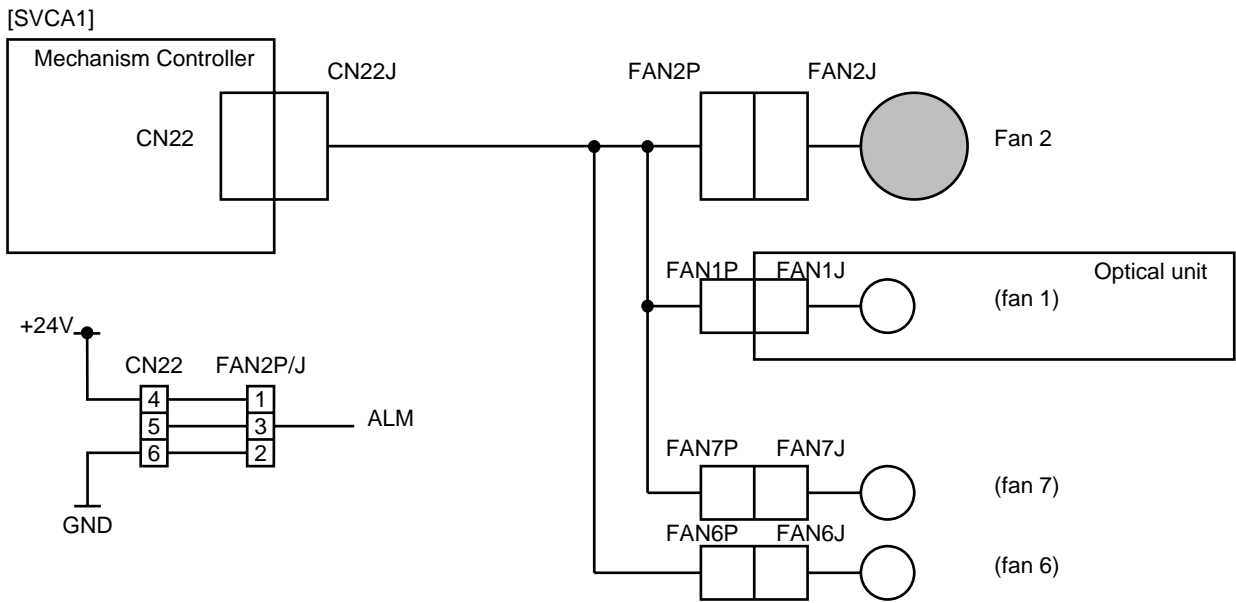

Figure 5-0. Fan Alarm 2 (SVCA1) Interconnections Diagram

5-2.1. SVCA5 Fan Alarm 6

Explanation

It was detected by the mechanism controller that the fan 6 did not rotate.

(Fan 6: cooling fan for the main controller above the main controller PCB)

Troubleshooting Procedure

<010> Remove the top cover, then check the fan during the printer power is on. Is the fan rotating? <Y:200, N:020>

<020> Is there something preventing the fan to rotate? <Y:022, N:030>

<022> Free the fan from anything preventing rotation.

<Exit>

<030> Check damages or pinches of the wires, cables, and connector (between CN22 on the mechanism controller PCB and FAN6P near the fan, between the CN7 on the power supply PCB and FAN6P). Confirm the voltage between pin 1 and pin 2 of the connector FAN6P is approximate 12V.

<110> Does this error still occur? <Y:120, N:Exit>

<120> Replace the fan 6.

<Exit>

<200> Check damages or pinches of the wires, cables, and connector (between CN22 on the mechanism controller and FAN6P near at the optical unit). Especially for the pin 3 of the connector FAN6P (alarm signal).

<210> Does this alarm still occur? <Y:220, N:Exit>

<220> Replace the mechanism controller PCB.

<Exit>

Caution

Do not bypass this error although you can do it by connect the pin 3 of the connector FAN6P to GND. It may cause damage on the main controller.

Troubleshooting Procedure

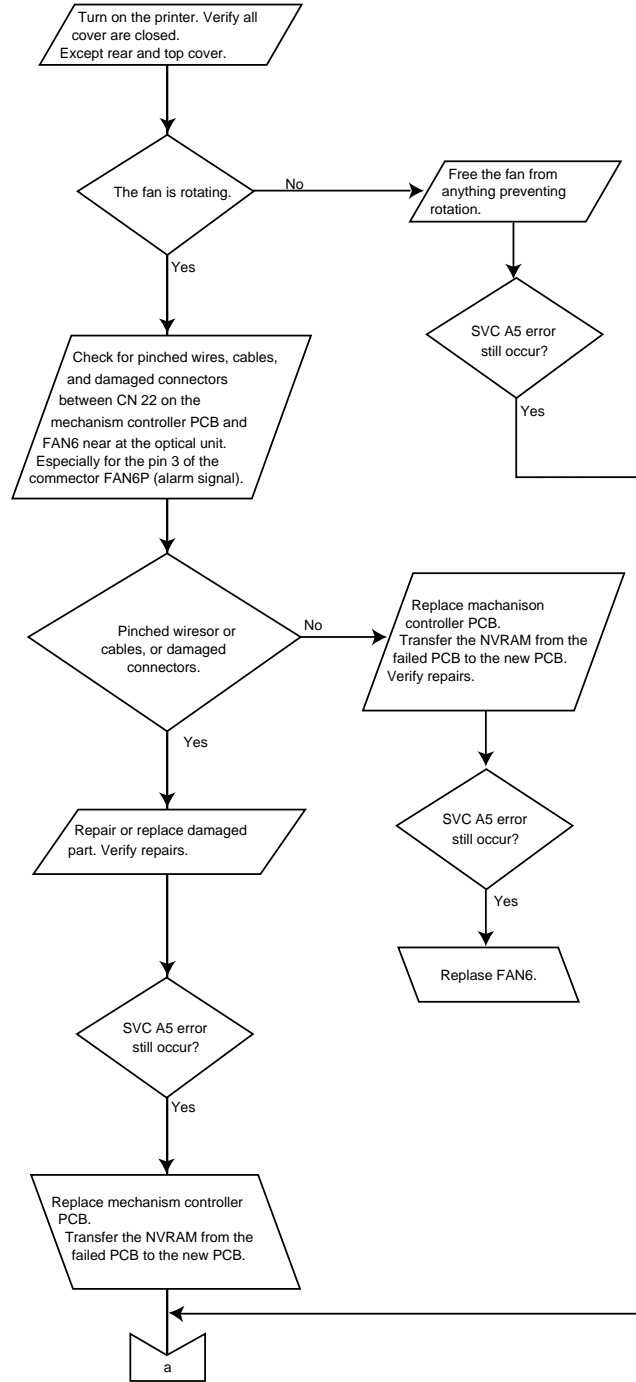

Figure 5-1. SVCA5 Fan Alarm 6 Flow Chart (1 of 2)

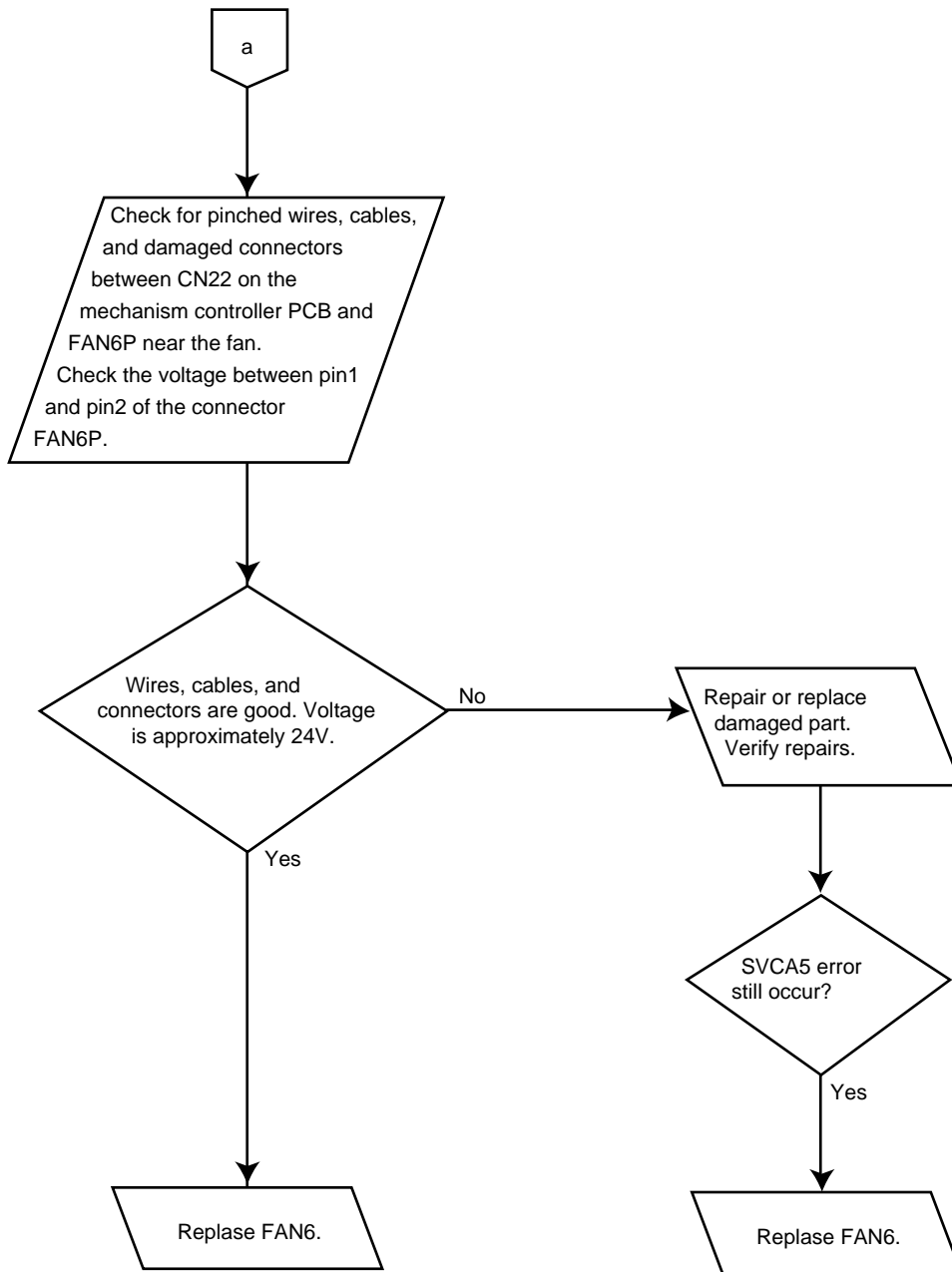

Figure 5-1. SVCA5 Fan Alarm 6 Flow Chart (2 of 2)

Reference Diagrams

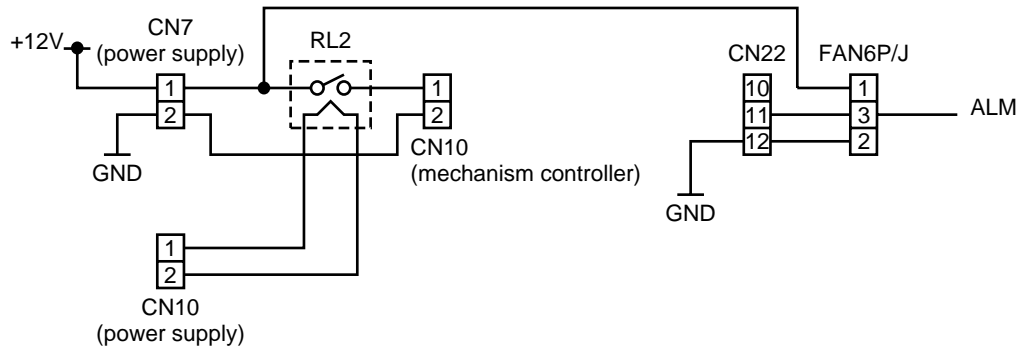
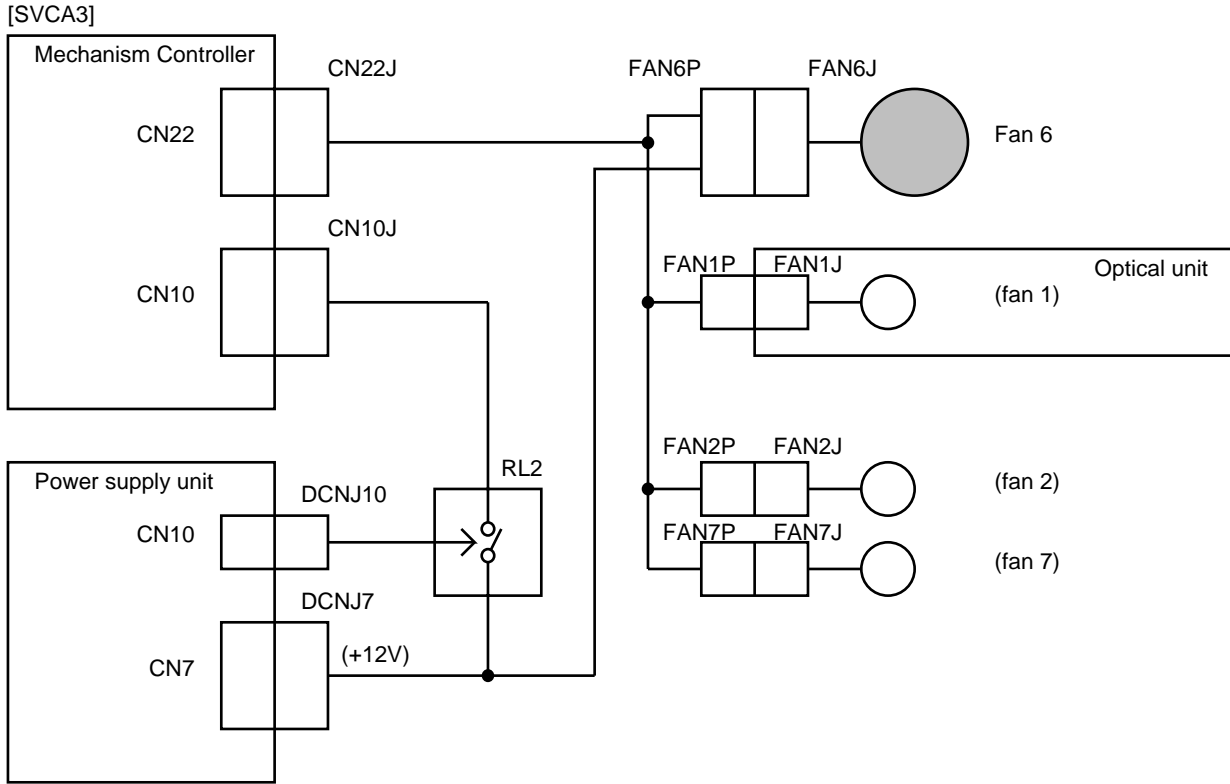

Figure 5-62. Fan Alarm 6 (SVCA3) Interconnections Diagram

5-2.2. SVCA6 Fan Alarm 7**Explanation**

It was detected by the mechanism controller that the fan 7 did not rotate. (Fan 7: internal cooling fan at lower left of the rear side of the printer)

Troubleshooting Procedure

<010> Remove the rear cover, then check the fan during the printer power is on. Is the fan rotating? <Y:200, N:020>

<020> Is there something preventing the fan to rotate? <Y:022, N:030>

<022> Free the fan from anything preventing rotation.

<Exit>

<030> Check damages or pinches of the wires, cables, and connector (between CN22 on the mechanism controller PCB and FAN7P near the fan). Confirm the voltage between pin 1 and pin 2 of the connector FAN7P is approximate 24V.

<110> Does this error still occur? <Y:120, N:Exit>

<120> Replace the fan 7.

<Exit>

<200> Check damages or pinches of the wires, cables, and connector (between CN22 on the mechanism controller and FAN7P near at the optical unit). Especially for the pin 3 of the connector FAN7P (alarm signal).

<210> Does this alarm still occur? <Y:220, N:Exit>

<220> Replace the mechanism controller PCB.

<Exit>

Caution

Do not bypass this error although you can do it by connect the pin 3 of the connector FAN7P to GND. It may cause another print quality problems or damage on the developing unit.

Troubleshooting Procedure

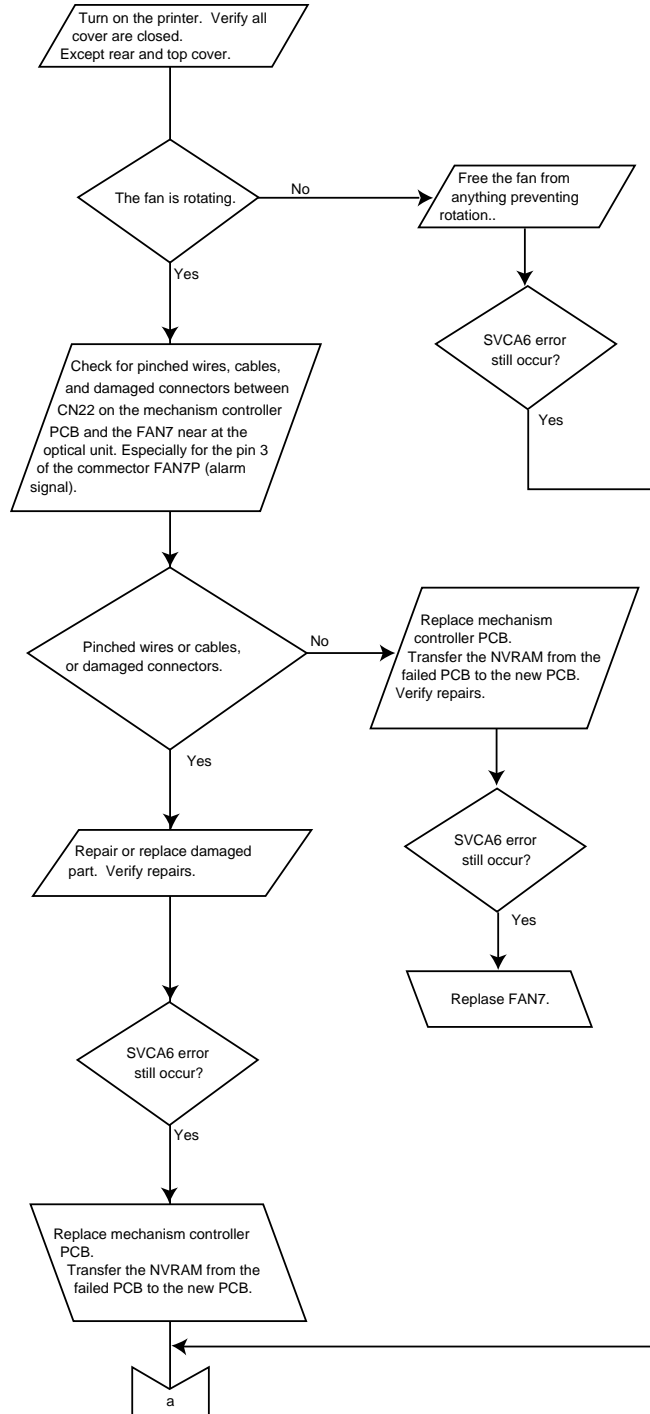

Figure 5-3. SVCA6 Fan Alarm 7 Flow Chart (1 of 2)

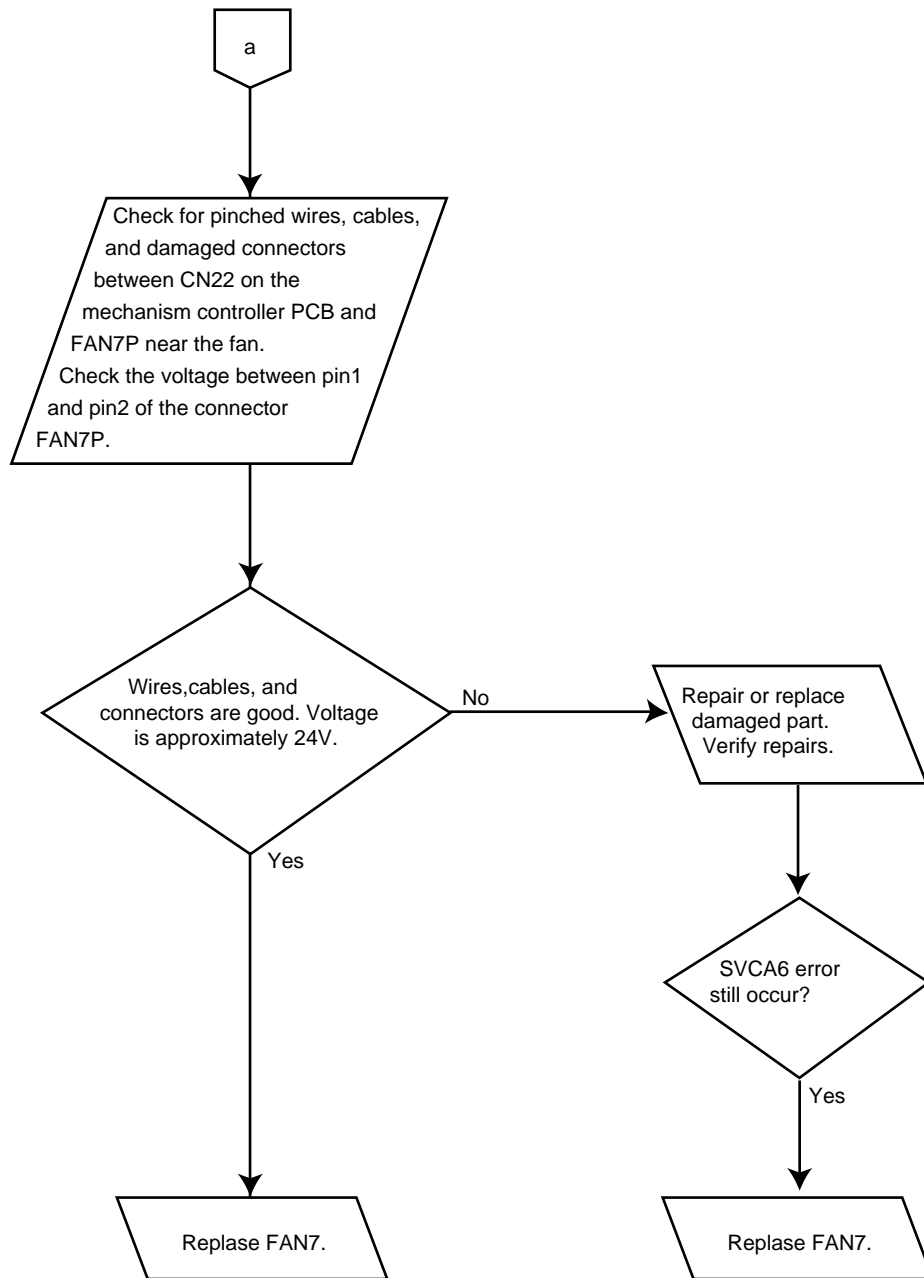

Figure 5-3. SVCA6 Fan Alarm 7 Flow Chart (2 of 2)

Reference Diagrams

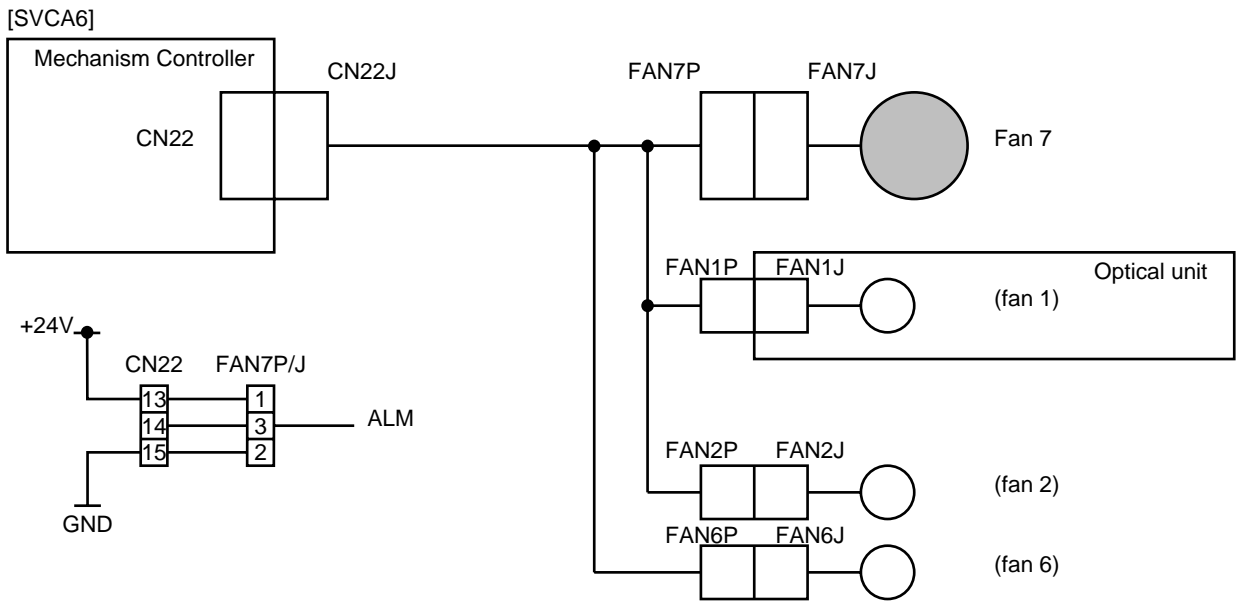

Figure 5-4. Fan Alarm 7 (SVCA6) Interconnections Diagram

5-2.2. SVCB0 Watchdog Timer Alarm—Master

Explanation

The master CPU of the mechanism controller overrun caused by a firmware bug was detected by the mechanism controller itself. This alarm occurs if the watchdog timer count is not reset from the master CPU within 94.8 ms.

Troubleshooting Procedure

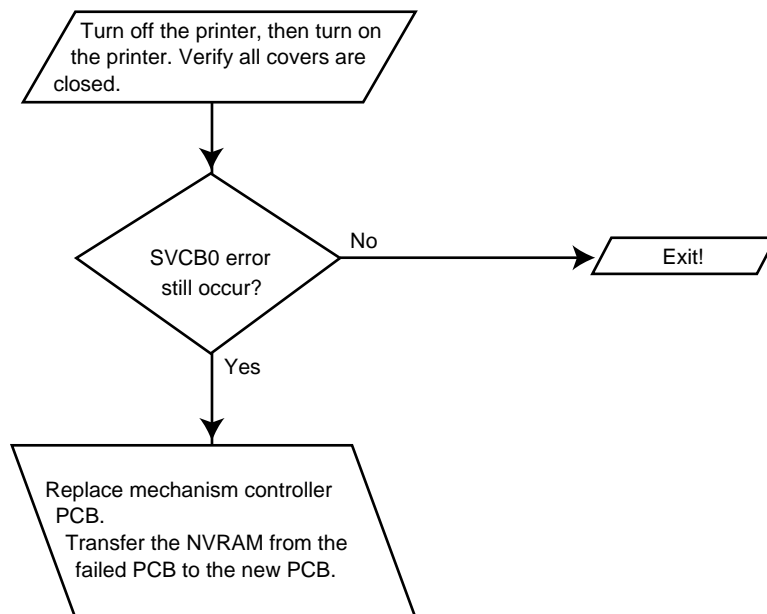

Figure 5-5. SVCB0 Watchdog Timer Alarm—Master Flow Chart

Reference Diagrams

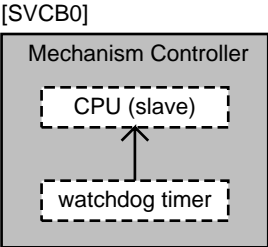

Figure 5-6. Watchdog Timer Alarm—Master (SVCB0) Interconnections Diagram

5-2.2. SVCB1 Watchdog Timer Alarm—Slave

Explanation

The slave CPU of the mechanism controller overrun caused by a firmware bug was detected by the mechanism controller itself. This alarm occurs if the watchdog timer count is not reset from the master CPU within 94.8 ms.

Troubleshooting Procedure

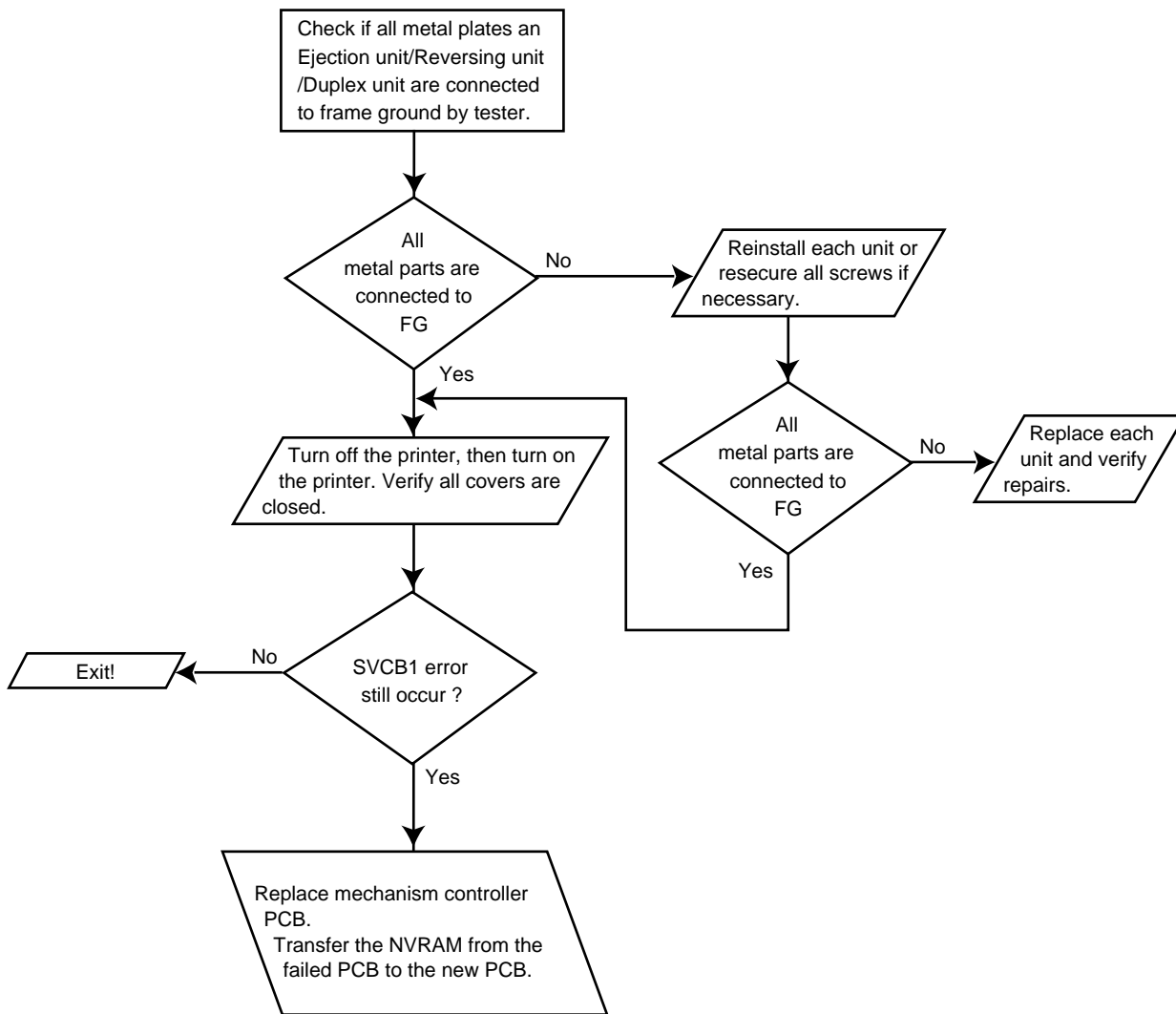

Figure 5-7. SVCB1 Watchdog Timer Alarm—Slave Flow Chart

Reference Diagrams

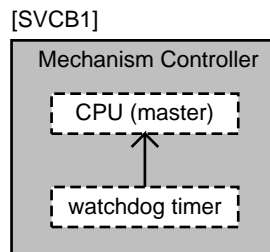

Figure 5-8. Watchdog Timer Alarm—Slave (SVCB1) Interconnections Diagram

5-2.2. SVCB3 Mechanism Controller Communication Alarm

Explanation

It was detected by the mechanism controller itself that the communication between the master and the slave CPU inside the mechanism controller is disabled. (The serial interface bit check, or the mutual hardware check, or the time-out of the master/slave communication in the mechanism controller PCB.)

Troubleshooting Procedure

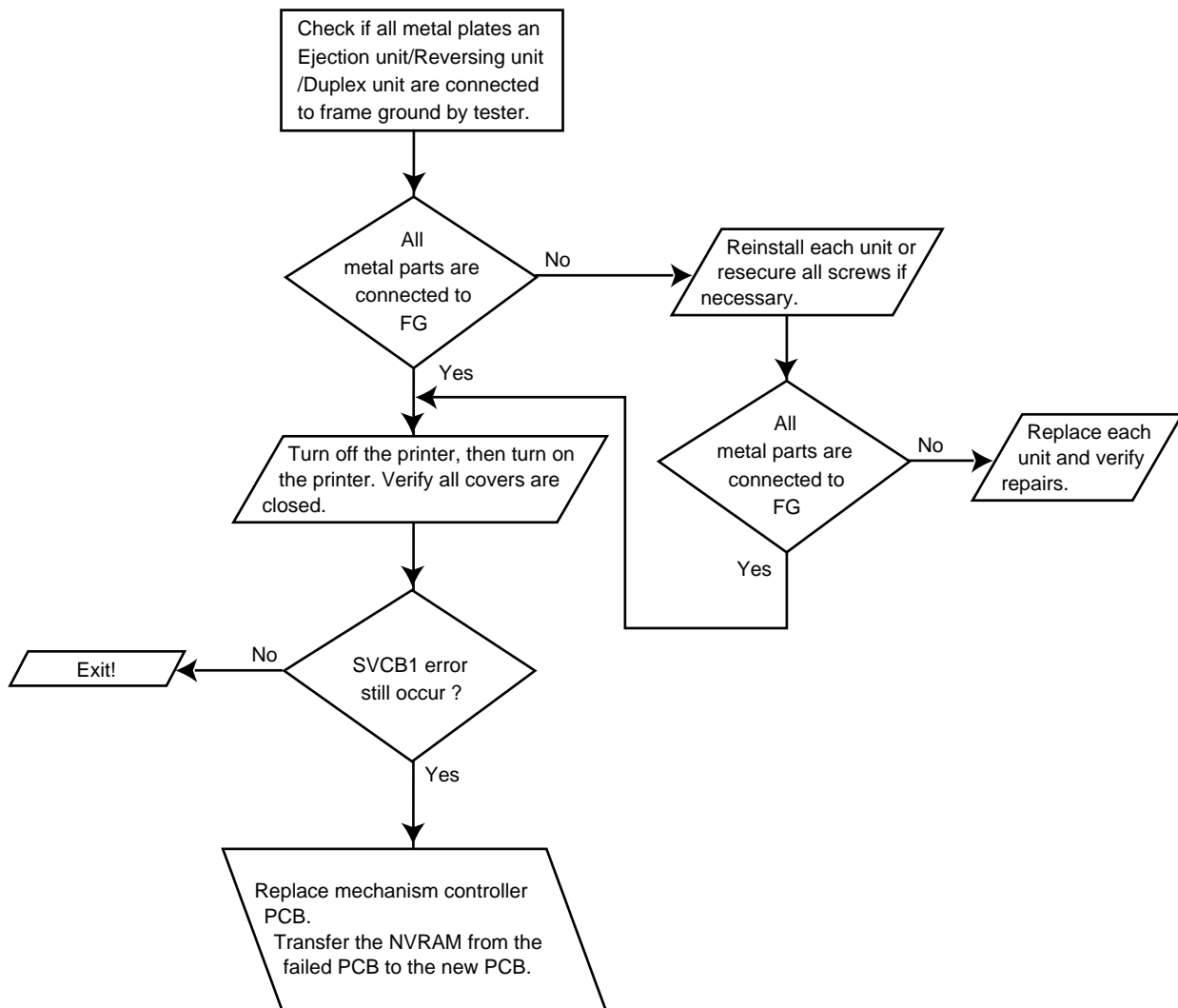

Figure 5-9. SVCB3 Mechanism Controller Communication Alarm Flow Chart

Reference Diagrams

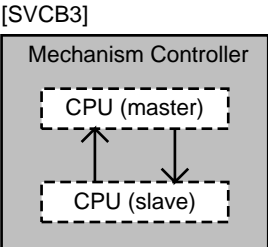

Figure 5-10. Mechanism Controller Communication Alarm (SVCB3) Interconnections Diagram

5-2.2. SVCB4 EEPROM Alarm

Explanation

One of the phenomenons below was detected by the mechanism controller:

- Data can not be written in NVRAM (EEPROM) on the mechanism controller, or
- After data is sent from the master CPU to NVRAM, acknowledgment is not returned, or
- Some alarm is detected by the NVRAM initialization check at power-on.

Troubleshooting Procedure

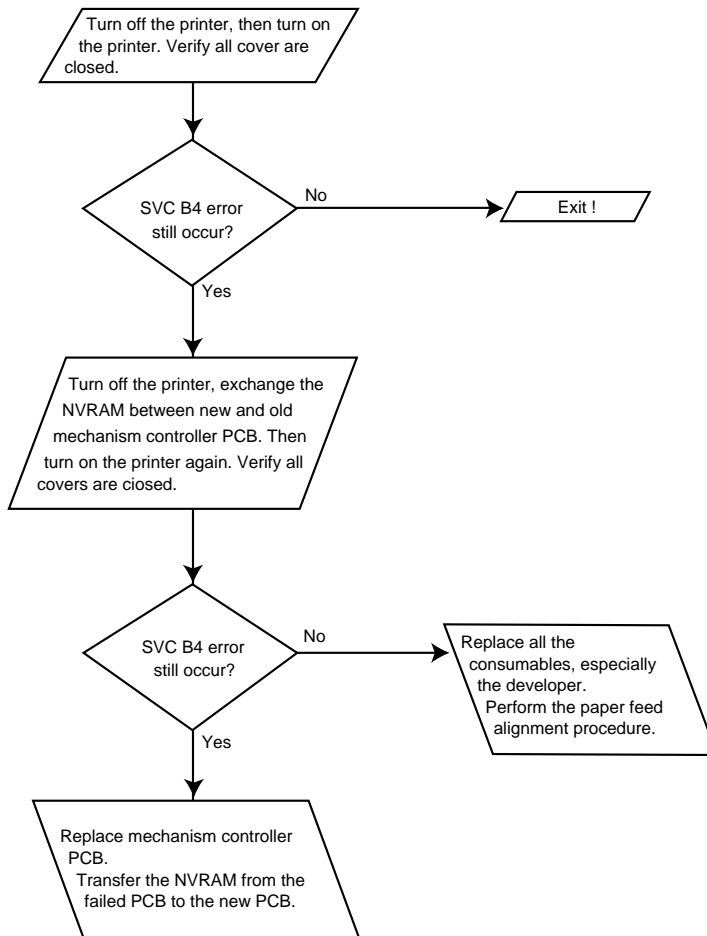

Figure 5-11. SVCB4 EEPROM Alarm Flow Chart

Reference Diagrams

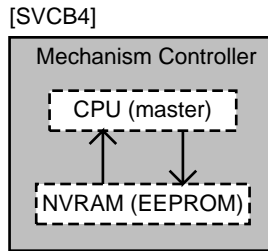

Figure 5-12. EEPROM Alarm (SVCB4) Interconnections Diagram

5-2.2. SVCB5 Video Synchronous (VS) Alarm

Explanation

It was detected by the mechanism controller that the VS (video synchronous) signal from the main controller is not received even after 10 sec have passed since the mechanism controller issued the VR (video request) signal.

Troubleshooting Procedure

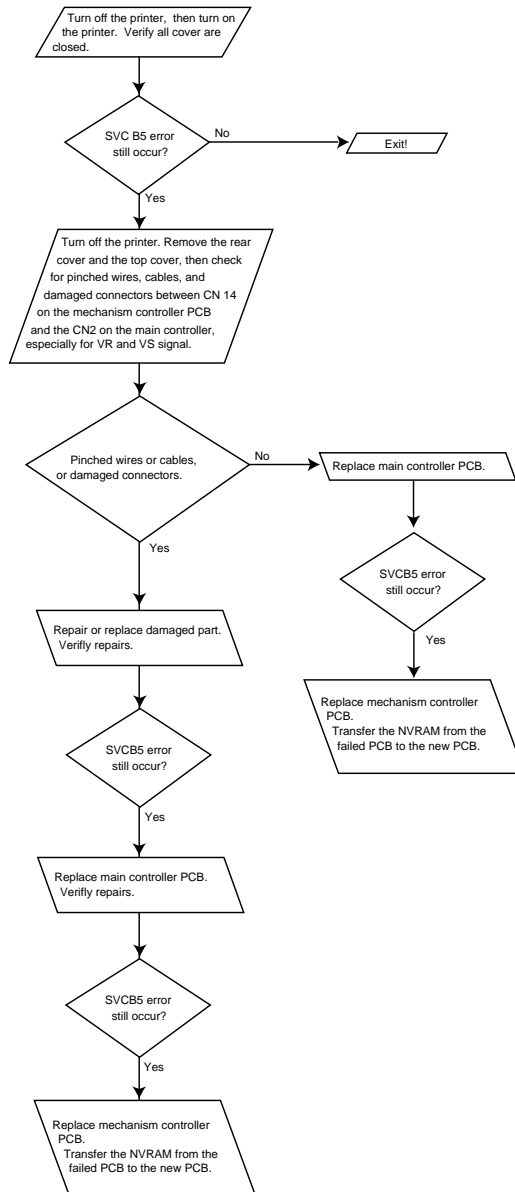

Figure 5-13. SVCB5 Video Synchronous (VS) Alarm Flow Chart

Reference Diagrams

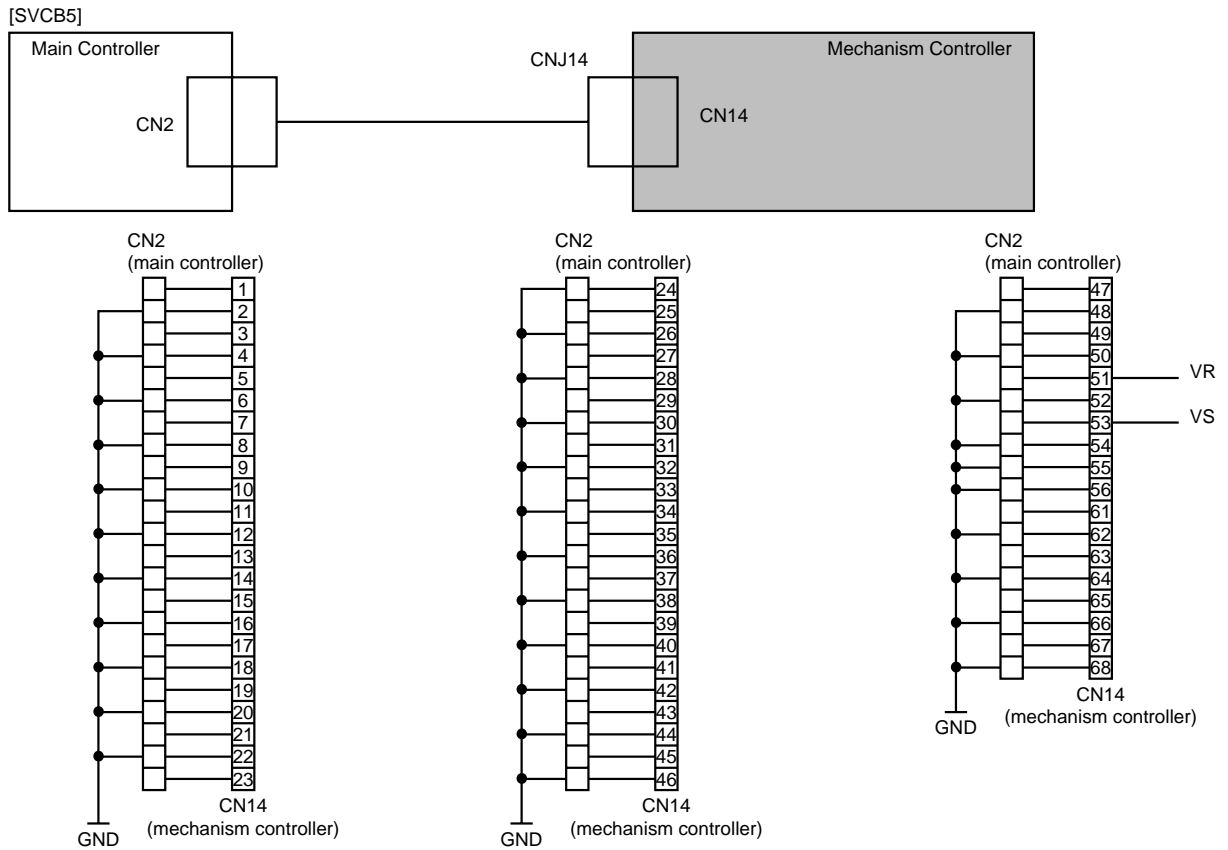

Figure 5-14. Video Synchronous (VS) Alarm (SVCB5) Interconnections Diagram

5-2.2. SVCB6 Pre-pick Alarm

Explanation

It was detected by the mechanism controller that none of the following commands from the main controller is received even after 20 sec have passed since the mechanism controller received the PREPK (prepick) command:

- PSTRT (print start) command
- TSTRT (test print start) command

Troubleshooting Procedure

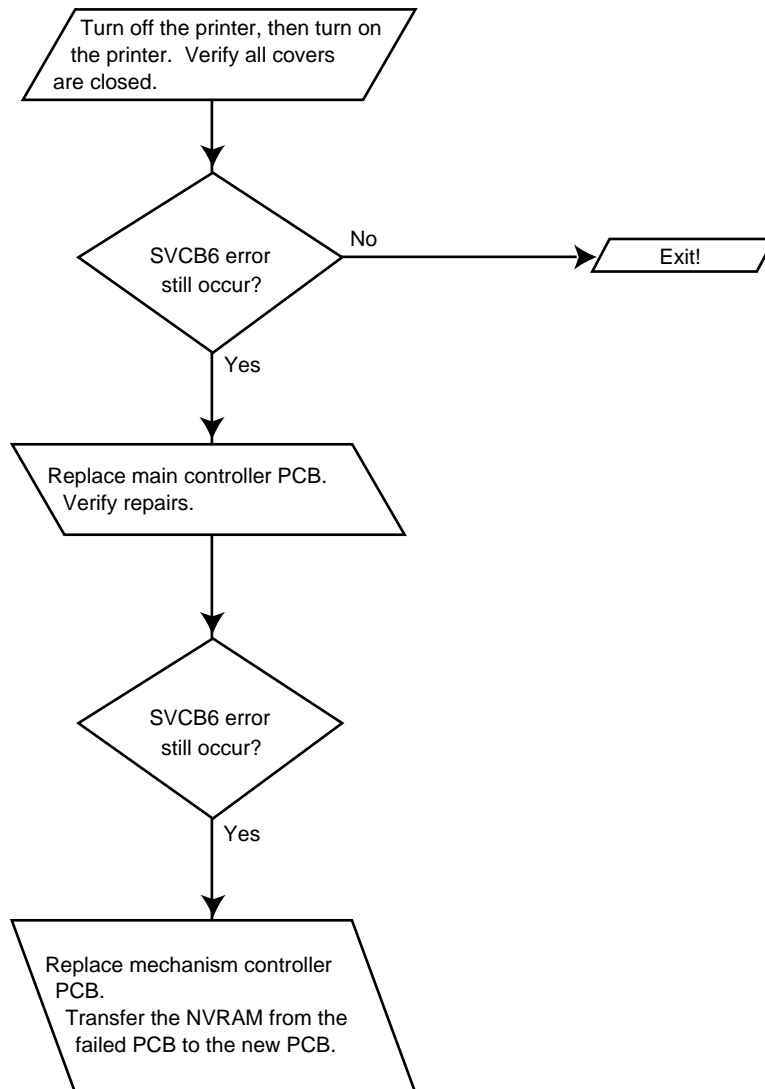

Figure 5-15. SVCB6 Pre-pick Alarm Flow Chart

Reference Diagrams

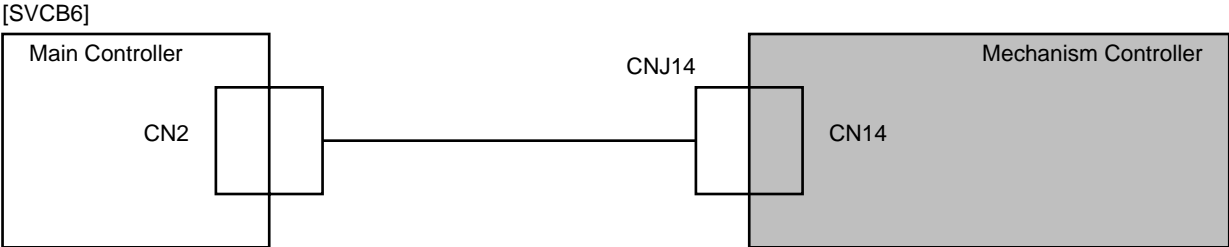

Figure 5-16. Pre-pick Alarm (SVCB6) Interconnections Diagram

5-2.2. SVCB7 Video Request (VR) Alarm

Explanation

It was detected by the mechanism controller itself that the mechanism controller does not issue the VR (video request) signal even after 40 sec have passed since the mechanism controller received the PSTRT (print start) command or TSTRT (test print start) command.

Troubleshooting Procedure

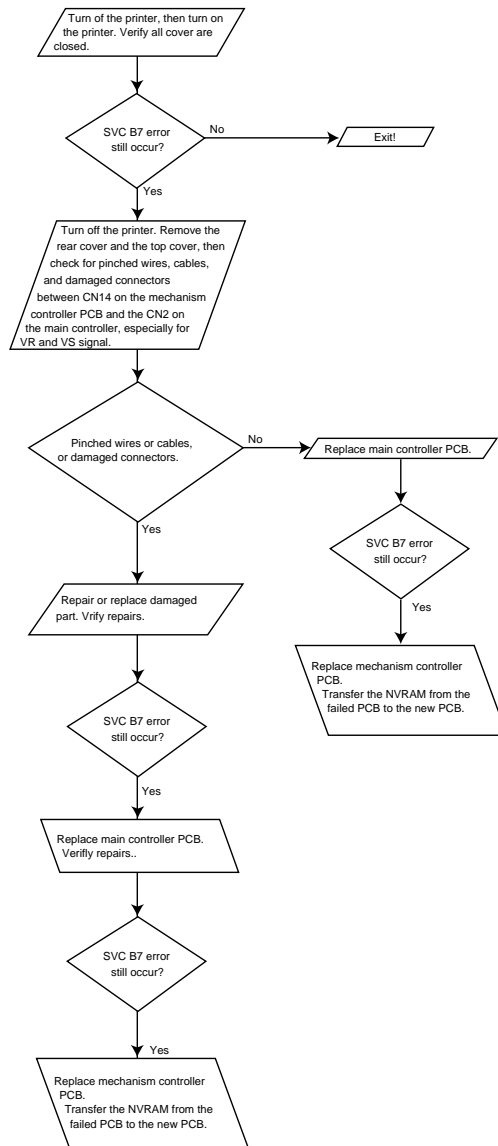

Figure 5-17. SVCB7 Video Request (VR) Alarm Flow Chart

Reference Diagrams

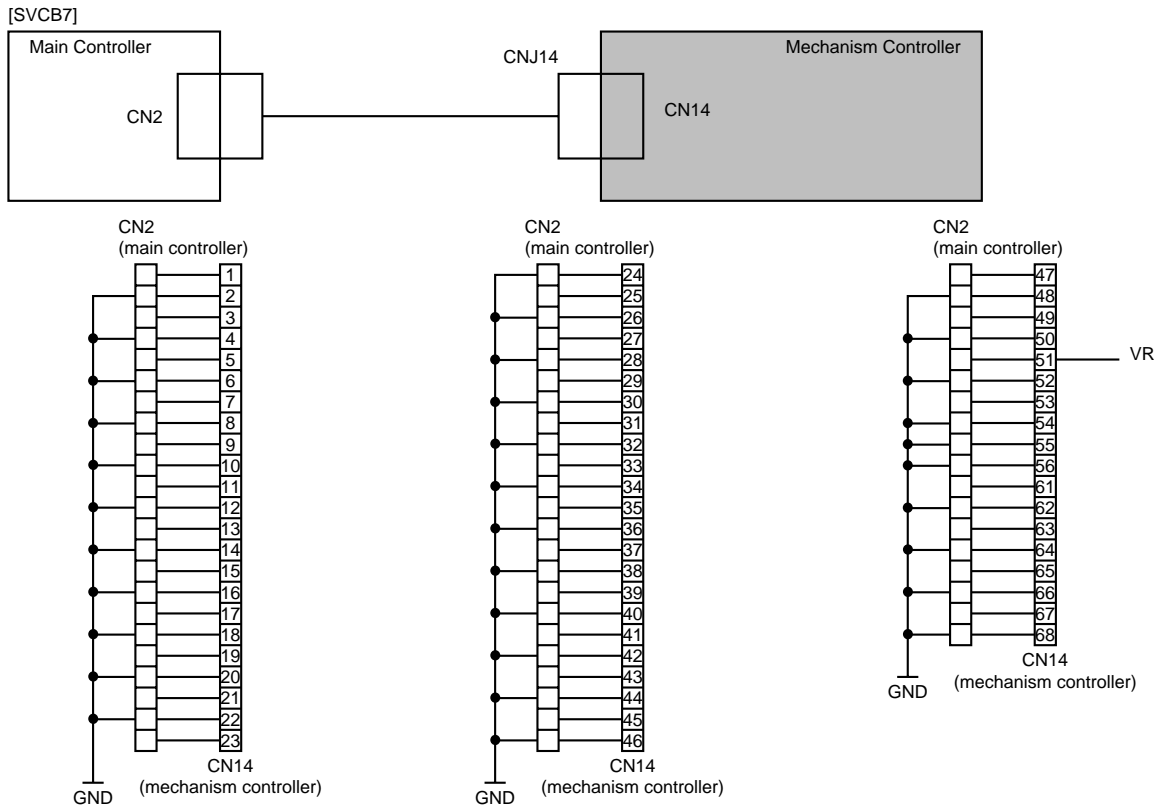

Figure 5-18. Video Request (VR) Alarm (SVCB7) Interconnections Diagram

5-3. Paper Jam Error Message Reported Problems

General

At any paper jam occurrence, check the following items before troubleshooting.

1. Check whether the paper being used meets the standard (especially for dimensions, thickness, smoothness, foreign particles, or something sticking the paper to each other).
2. Check whether the paper is handled correctly (especially for creases or wrinkles).
3. Check whether the environment, both for the printer and the paper itself, meets standards (especially for humidity).
4. Check whether the rollers and the paper guides near the jam are clean (especially for scattered toner or developer, accumulated paper powder, and paper pieces).

5-3.2. JAM01/02/03 Pick Error

Explanation

Paper did not reach sensor PS1-1 or PS1-2 or PS1-3 from the respective tray before specified time passed after the pick roller started.

Troubleshooting Procedure

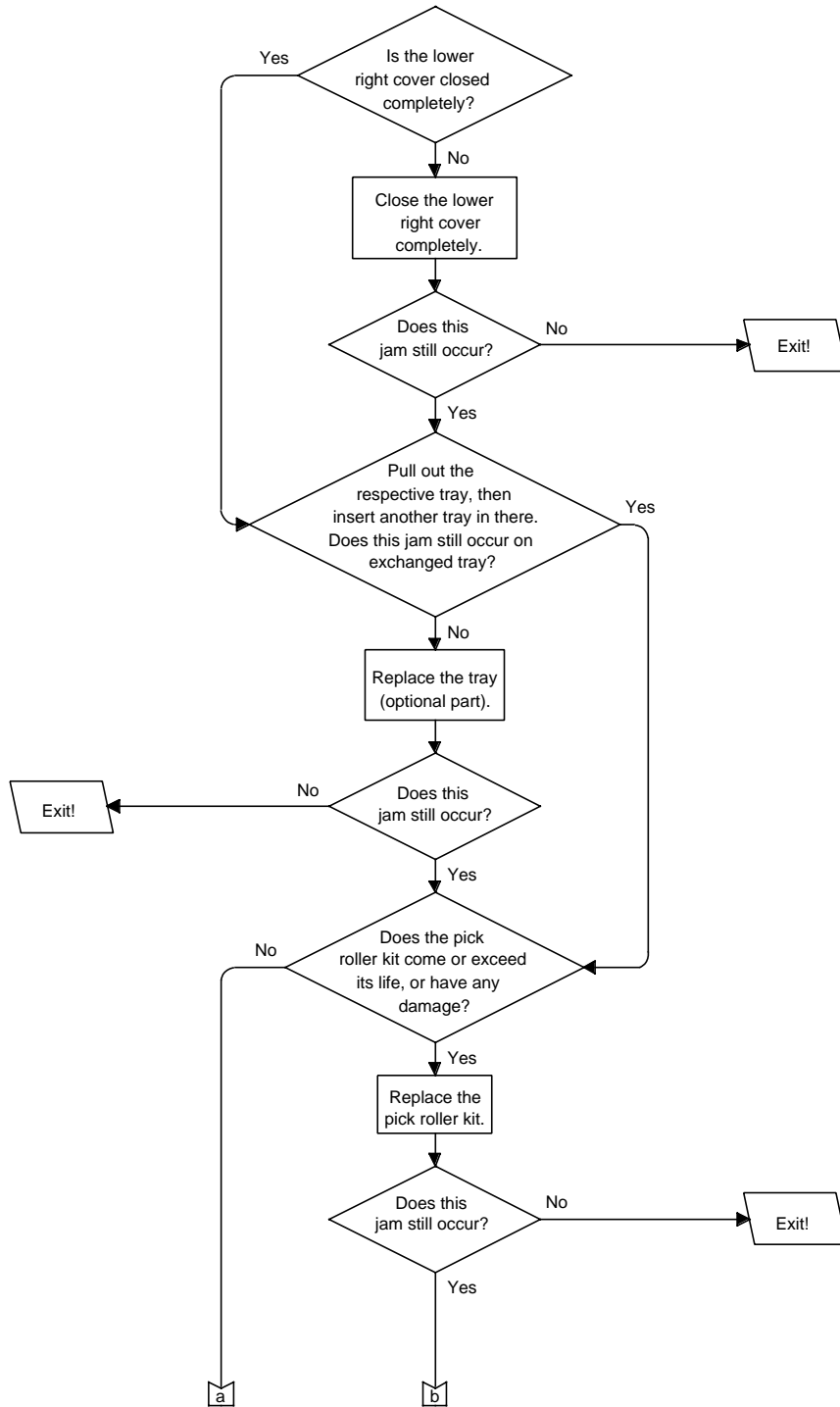

Figure 5-19. JAM01/02/03 Pick Error Flow Chart (1 of 4)

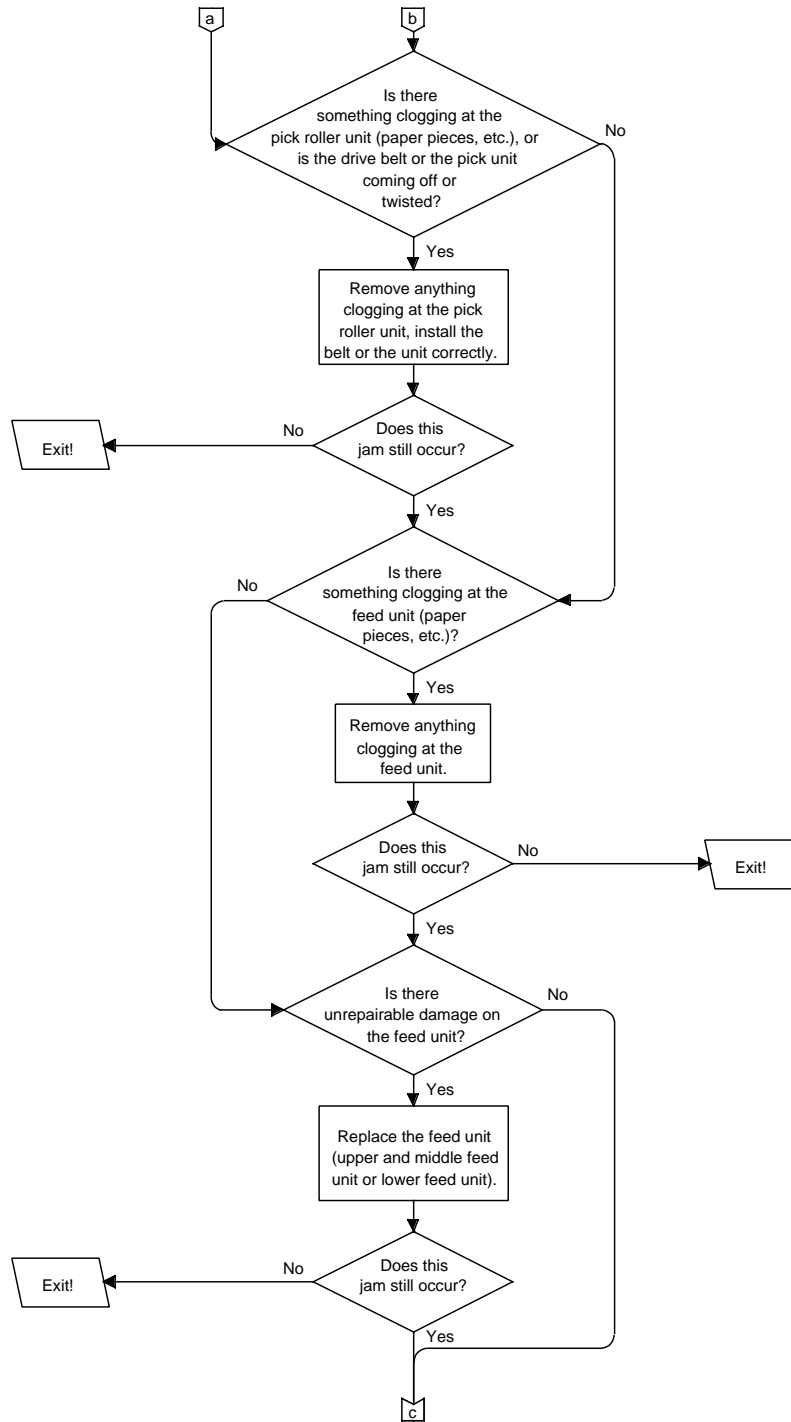

Figure 5-19. JAM01/02/03 Pick Error Flow Chart (2 of 4)

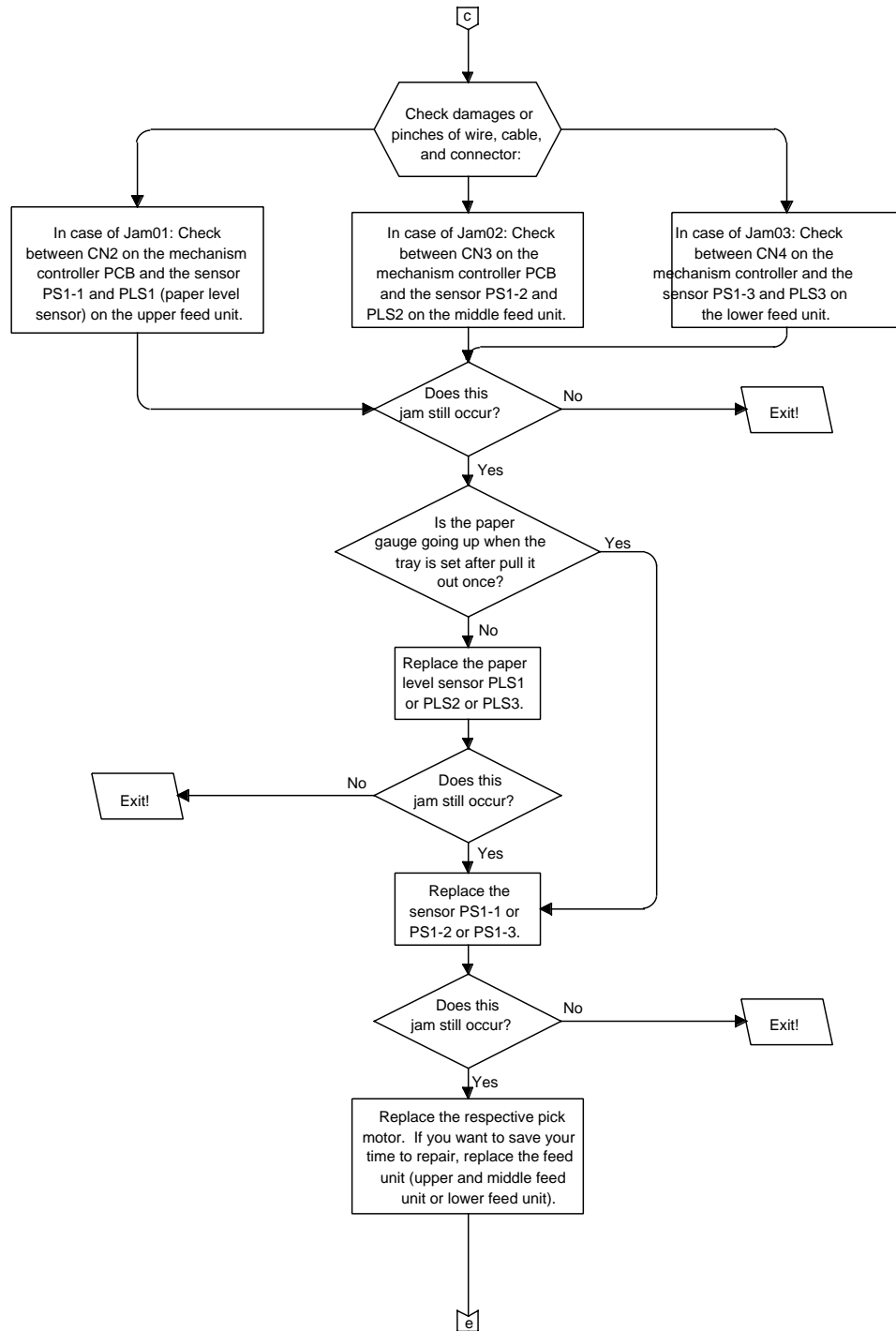

Figure 5-19. JAM01/02/03 Pick Error Flow Chart (3 of 4)

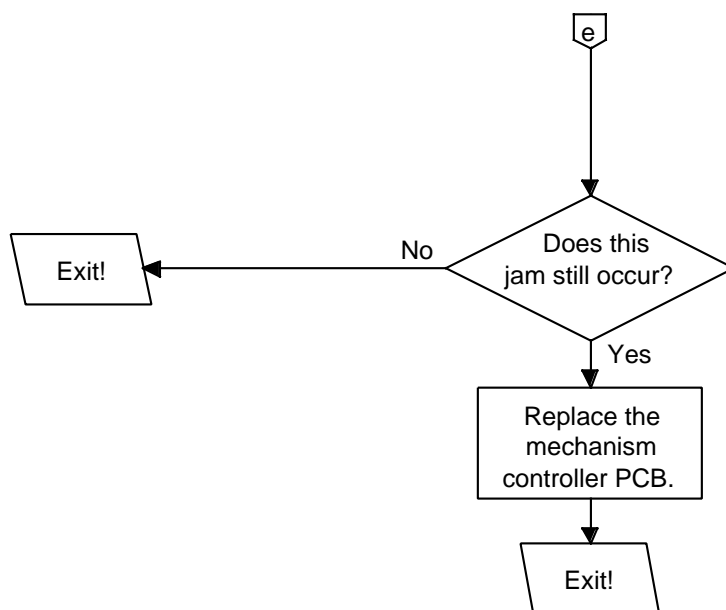

Figure 5-19. JAM01/02/03 Pick Error Flow Chart (4 of 4)

Reference Diagrams

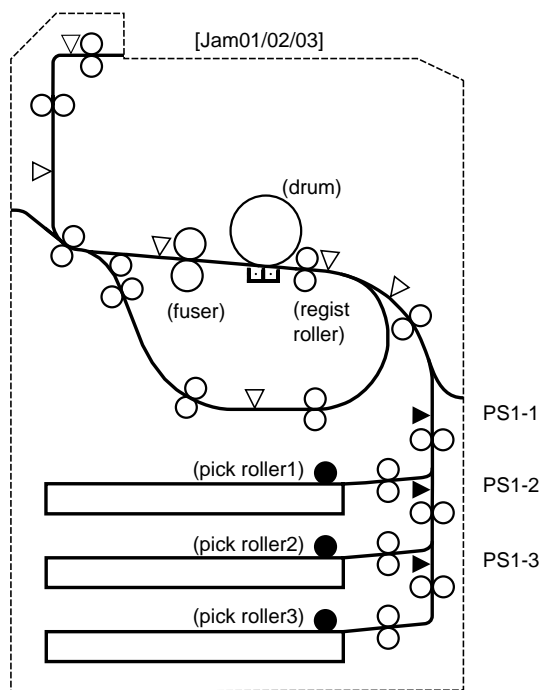

Figure 5-20. Pick Error (JAM01/02/03) Sensor Locations

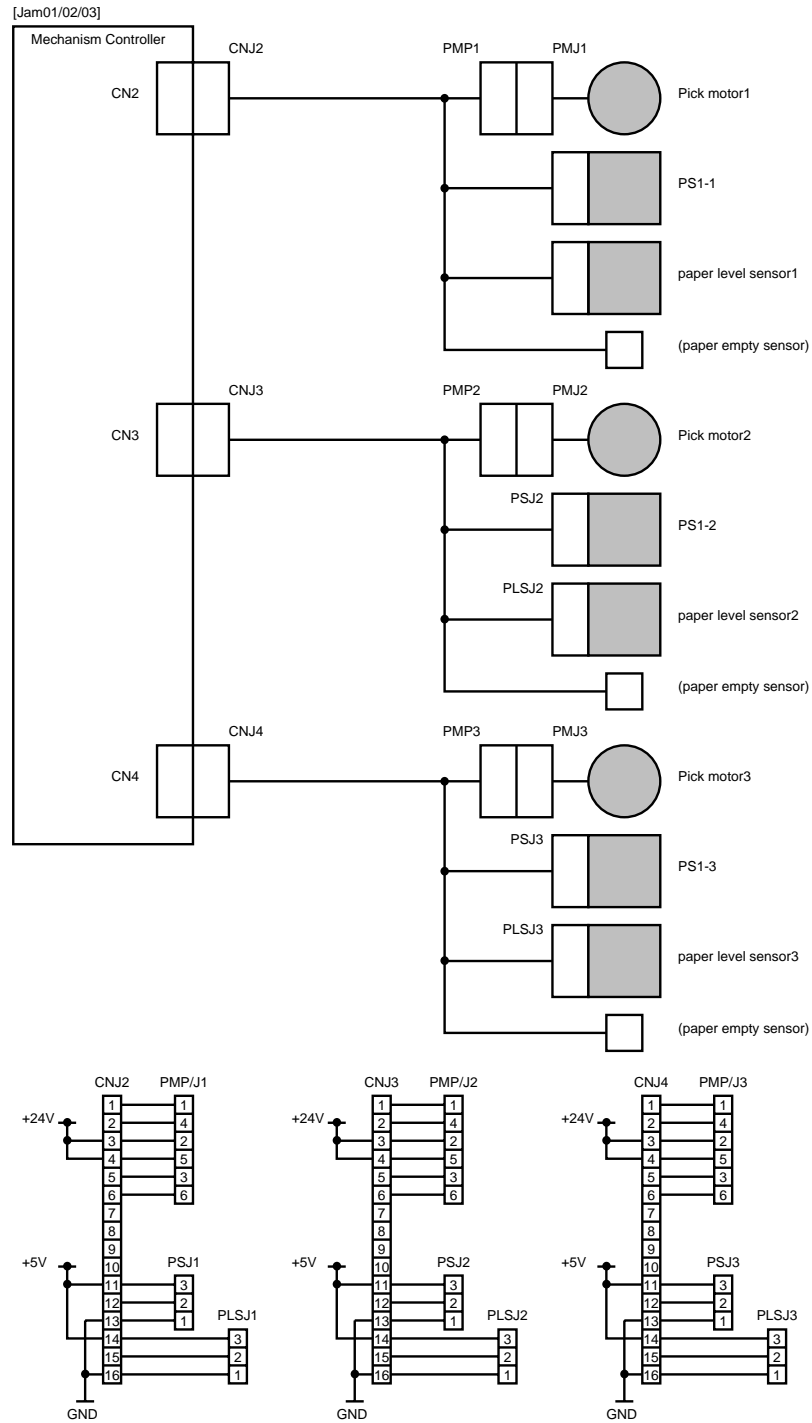

Figure 5-21. Pick Error (JAM01/02/03) Interconnections Diagram

5-3.2. JAM11/12/13 Feed Jam 1**Explanation**

When the printer is reset, there is paper at PS1-1 or 1-2 or 1-3 sensor, or

Paper did not reach PS2 sensor before specified time passed after the paper reached PS1-1 or 1-2 or 1-3 sensor, or

When a paper is picked without any retry, PS1-1 or 1-2 or 1-3 sensor is already on (paper is in).

Troubleshooting Procedure

<010> Does this jam occurs before the paper is fed? (then the problem may on PS1 sensor, else on PS2 or feeding mechanism) <Y:020, N:100>

<020> Is there something clogging at the PS1-1 or PS1-2 or PS1-3 sensor (paper pieces, etc.)? <Y:022, N:030>

<022> Remove anything clogging at the sensor.

<024> Does this jam still occur? <Y:030, N:Exit>

<030> Replace the sensor PS1-1 or PS1-2 or PS1-3.

<032> Does this jam still occur? <Y:040, N:Exit>

<040> Check damages or pinches of wire, cable, and connector.

In case of Jam11: Check between CN2 on the mechanism controller PCB and the sensor PS1-1 on the upper feed unit.

In case of Jam12: Check between CN3 on the mechanism controller PCB and the sensor PS1-2 on the middle feed unit.

In case of Jam13: Check between CN4 on the mechanism controller PCB and the sensor PS1-3 on the lower feed unit.

<042> Does this jam still occur? <Y:200, N:Exit>

<100> Remove the lower right cover and the column cover, then check the transport rollers (rollers of the lower right cover) and the drive belt.

<110> Is there something clogging at the transport rollers, or the drive belt coming off or twisted? <Y:112, N:120>

<112> Remove anything clogging at the rollers, install the belt correctly.

<114> Does this jam still occur? <Y:120, N:Exit>

<120> Is there unrepairable damage on the transport rollers? <Y:122, N:130>

<122> Replace the transport roller.

<124> Does this jam still occur? <Y:130, N:Exit>

<130> Remove the rear cover, then check damages or pinches of wires, cables, and connectors between CN23 on the mechanism controller PCB and the sensor PS2.

<132> Does this jam still occur? <Y:140, N:Exit>

<140> Is there something clogging at the feed unit (paper pieces, etc.) or the drive belt coming off or twisted? <Y:142, N:150>

<142> Remove anything clogging at the feed unit, install the belt correctly.

<144> Does this jam still occur? <Y:150, N:Exit>

<150> Is there unrepairable damage on the belt of the feed unit? <Y:152, N:160>

<152> Replace the belt.

<154> Does this jam still occur? <Y:160, N:Exit>

<160> Check damages or pinches of wire, cable, and connector between CN6 on the mechanism controller PCB and the feed motor.

<162> Does this jam still occur? <Y:164, N:Exit>

<164> Try test printing. Does the feed motor rotate? <Y:170, N:166>

<166> Replace the feed motor.

<168> Does this jam still occur? <Y:170, N:Exit>

<170> Is there unrepairable damage (locked with bending or transforming) on any rollers of the feed unit? <Y:172, N:180>

<172> Replace the roller. If you want to save your time to repair, replace the feed unit (upper and middle feed unit or lower feed unit).

<174> Does this jam still occur? <Y:180, N:Exit>

<180> Is there unrepairable damage on the feed unit? <Y:182, N:190>

<182> Replace the feed unit (upper and middle feed unit or lower feed unit).

<184> Does this jam still occur? <Y:190, N:Exit>

<190> Replace the PS2.

<192> Does this jam still occur? <Y:200, N:Exit>

<200> Replace the mechanism controller PCB.

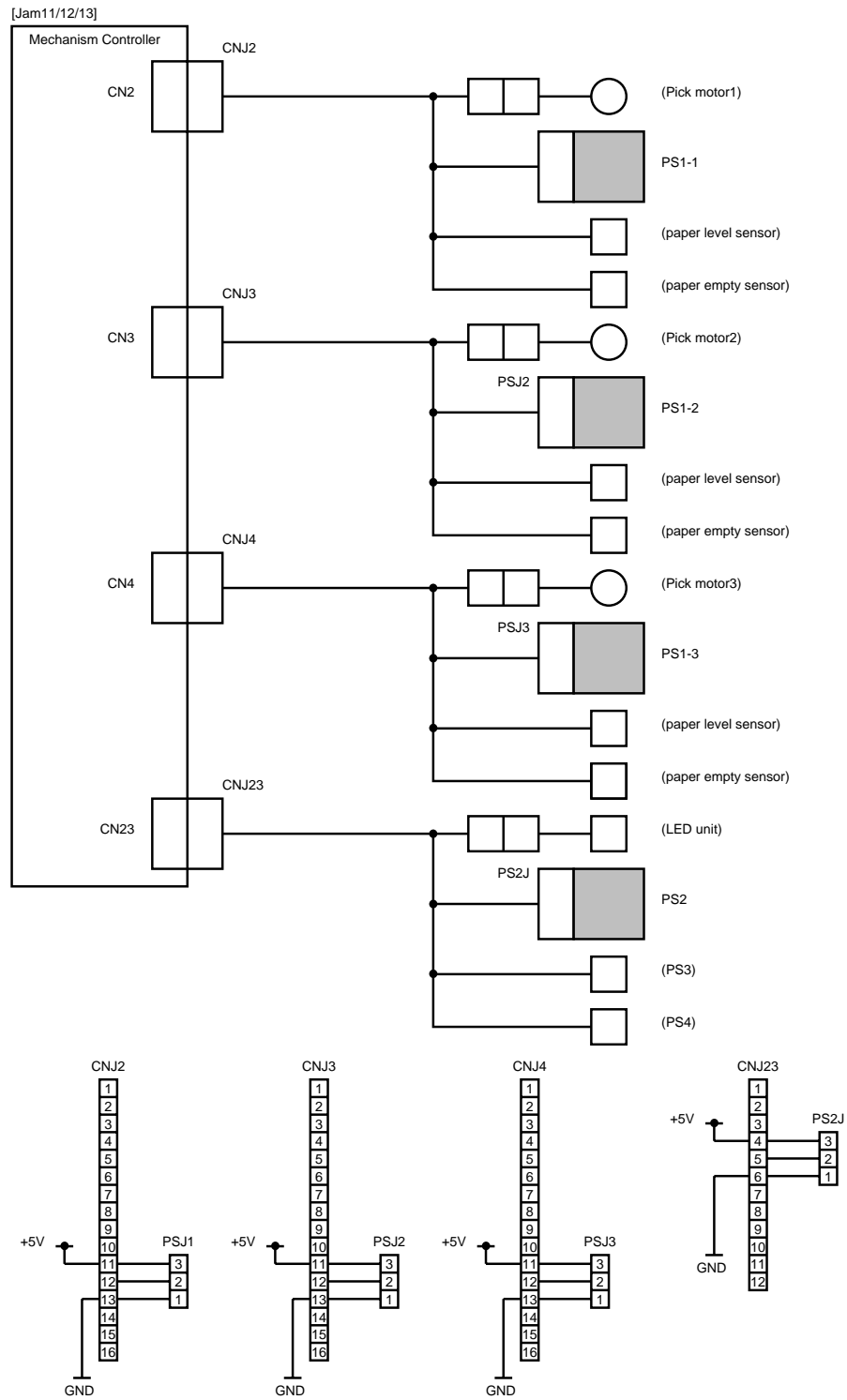

Figure 5-23. Feed Jam (JAM11/12/13) Interconnections Diagram (1 of 2)

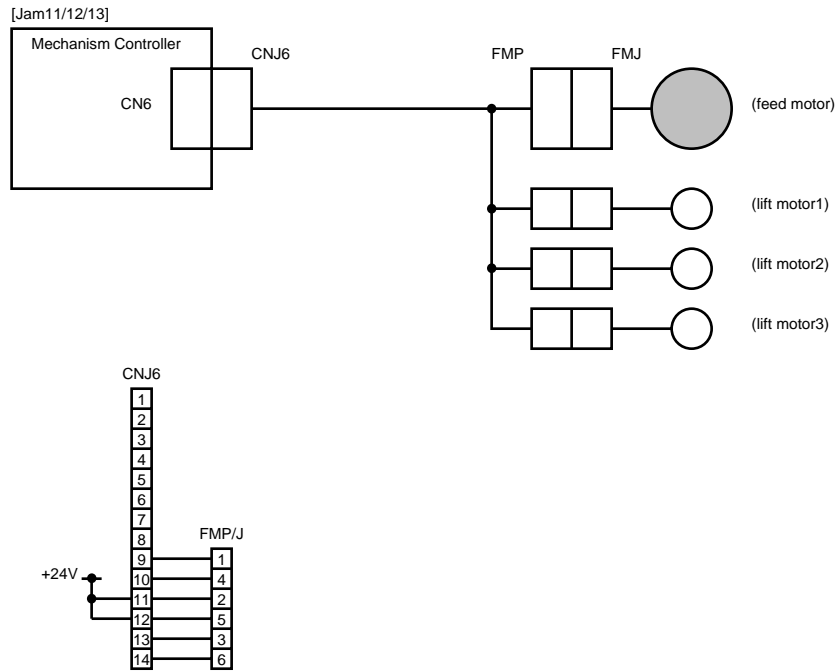

Figure 5-23. Feed Jam (JAM11/12/13) Interconnections Diagram (2 of 2)

5-3.2. JAM18 Feed Jam 2

Explanation

When the printer is reset, there is paper at PS2 sensor, or Paper did not reach PS3 sensor before specified time passed after the paper reached PS2.

Troubleshooting Procedure

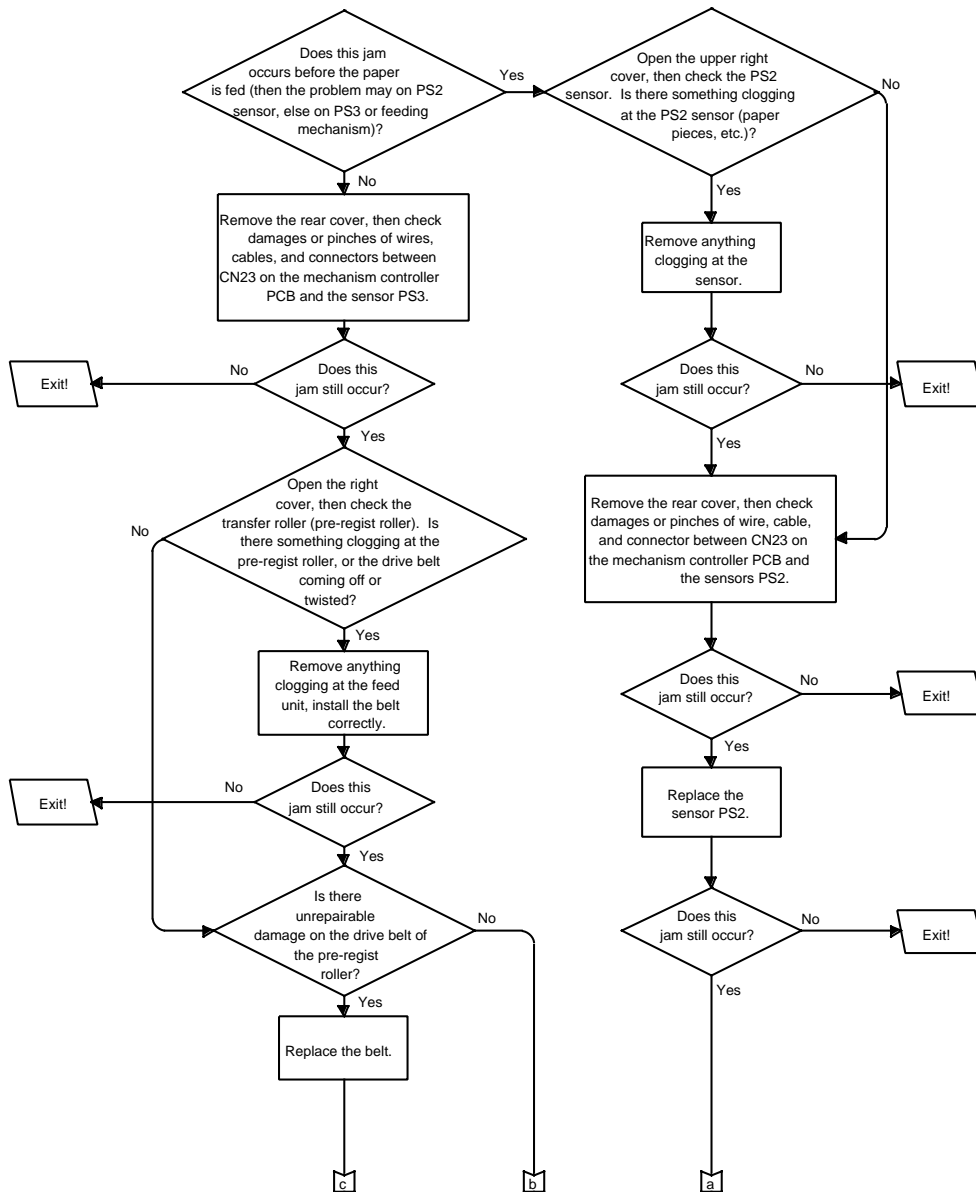

Figure 5-24. JAM18 Feed Jam Flow Chart (1 of 2)

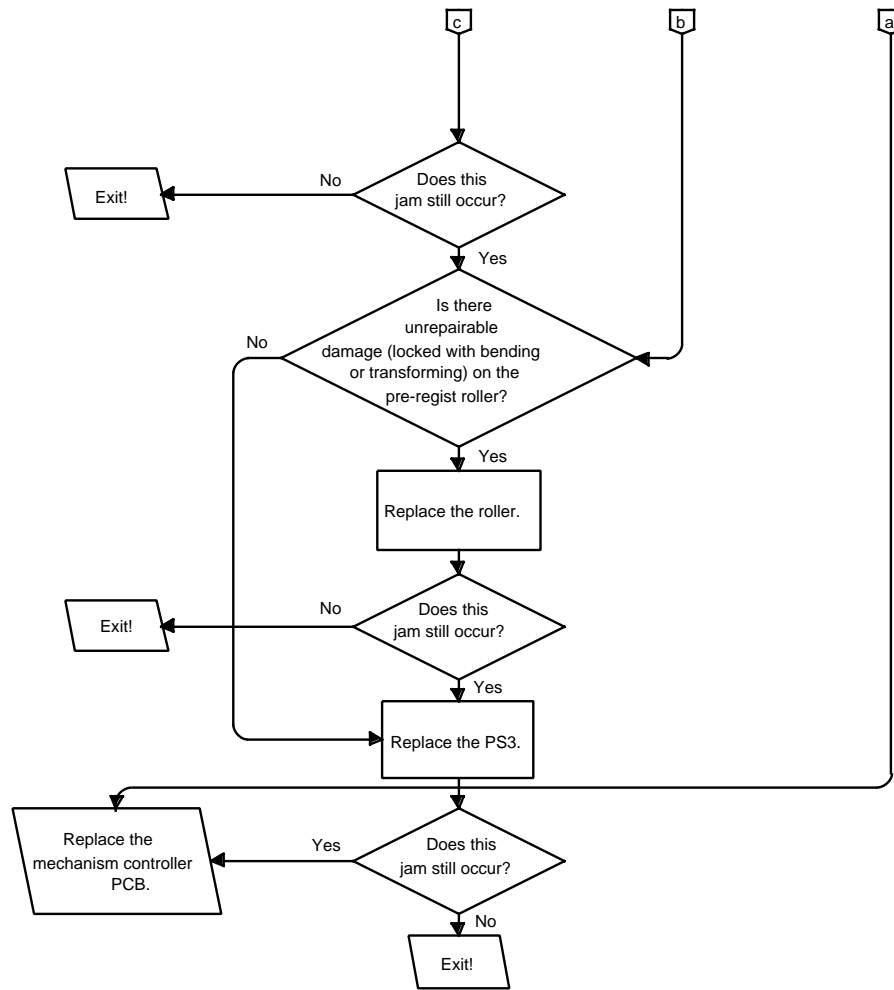

Figure 5-24. JAM18 Feed Jam Flow Chart (2 of 2)

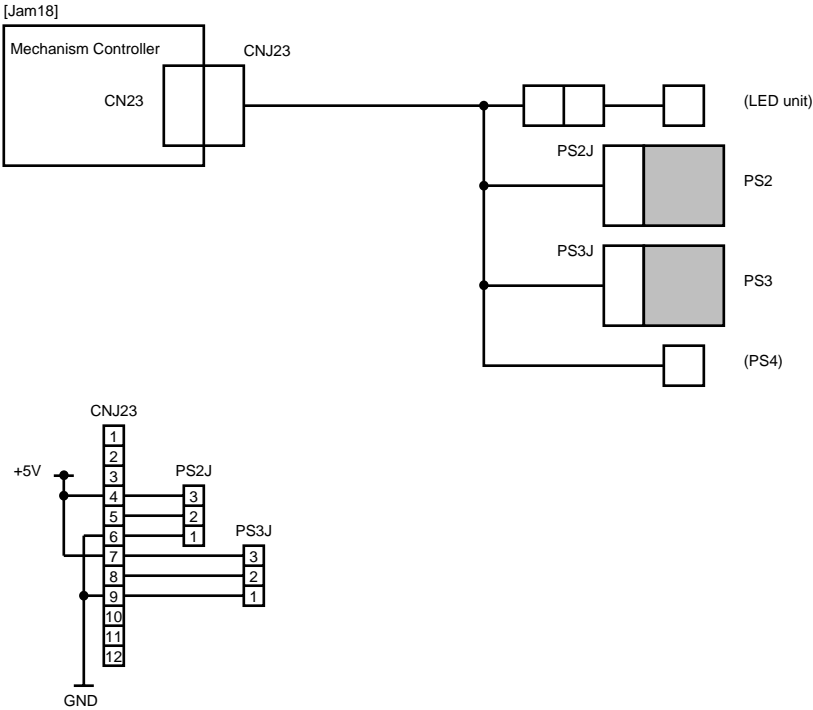

Figure 5-26. Feed Jam (JAM18) Interconnections Diagram

5-3.2. JAM25 Fuser Unit Jam 1**Explanation**

When the printer is reset, there is paper at PS3 sensor, or

Paper did not reach PS4 sensor before specified time passed after the reverse roller clutch (RRCL) is turned on, or

Paper did not leave PS2 sensor before specified time passed after the reverse roller clutch (RRCL) is turned on.

Troubleshooting Procedure

<010> Is the paper size setting and the actual paper size installed in the tray matched? <Y:020, N:012>

<012> Set the paper size correctly.

<014> Does this jam still occur? <Y:020, N:Exit>

<020> Does this jam occur before the paper is fed? (then the problem may on PS3 sensor, else on PS4 or RRCL or feeding mechanism) <Y:030, N:100>

<030> Is there something clogging at the PS3 sensor (paper pieces, etc.)? <Y:032, N:040>

<032> Remove anything clogging at the sensor.

<034> Does this jam still occur? <Y:040, N:Exit>

<040> Remove the rear cover, then check damages or pinches of wire, cable, and connector between CN23 on the mechanism controller PCB and the sensor PS3.

<042> Does this jam still occur? <Y:050, N:Exit>

<050> Replace the sensor PS3.

<052> Does this jam still occur? <Y:300, N:Exit>

<100> Is the leading edge of the paper stopped just at the regist roller? <Y:250, N:110>

<110> Is the jammed paper stopped around the transfer unit or missing or winding around the photoconductor drum? <Y:120, N:150>

<120> If there is a paper wining around the drum, remove it. Be care not to damage the drum. Then check the transfer charger and the transfer unit guide. Is there any unreparable damage on the transfer charger or the guide? <Y:122, N:124>

<122> Replace the transfer charger (packed within the developer kit: CA81218-E006, fig.7-2) or the transfer unit guide.

<123> Go to 126.

<124> Clean the transfer charger and the transfer unit guide. Be care not to damage the drum or charger.

<126> Does this jam still occur? <Y:130, N:Exit>

<130> Remove the rear cover, then check damages or pinches of +HV and ACH cable from the high voltage power supply PCB to the transfer unit.

<132> Does this jam still occur? <Y:140, N:Exit>

<140> Replace the high voltage power supply unit (CA02951-3621, see 4-52, fig.4-10).

<142> Does this jam still occur? <Y:300, N:Exit>

<150> Is the jammed paper stopped around the fuser unit or missing or winding around the fuser unit? <Y:160, N:180>

<160> Clean the guides or rollers of the fuser and the de-curler unit.

<162> Does this jam still occur? <Y:170, N:Exit>

<170> Replace the fuser.

<172> Does this jam still occur? <Y:300, N:Exit>

<180> Try test printing while press down the actuator of PS4 with adhesive tape.

<190> Is the Jam26 occurred? <Y:250, N:200>

<200> Is there something clogging at the PS4 sensor (paper pieces, etc.)? <Y:202, N:210>

<202> Remove anything clogging at the sensor.

<204> Does this jam still occur? <Y:210, N:Exit>

<210> Remove the rear cover, then check damages or pinches of wire, cable, and connector between CN23 on the mechanism controller PCB and the sensors PS4.

<212> Does this jam still occur? <Y:220, N:Exit>

<220> Replace the sensor PS4.

<222> Does this jam still occur? <Y:300, N:Exit>

<250> Is there any unrepairable damage (locked with bending or transforming) on the regist roller? <Y:252, N:260>

<252> Replace the regist roller.

<254> Does this jam still occur? <Y:260, N:Exit>

<260> Try test printing. Does the regist roller rotate? <Y:300, N:262>

<262> Check damages or pinches of wire, cable, and connector between CN21 on the mechanism controller PCB and the regist roller clutch RRCL.

<264> Does this jam still occur? <Y:266, N:Exit>

<266> Replace the regist roller clutch RRCL.

<268> Does this jam still occur? <Y:300, N:Exit>

<300> Replace the mechanism controller PCB.

Reference Diagrams

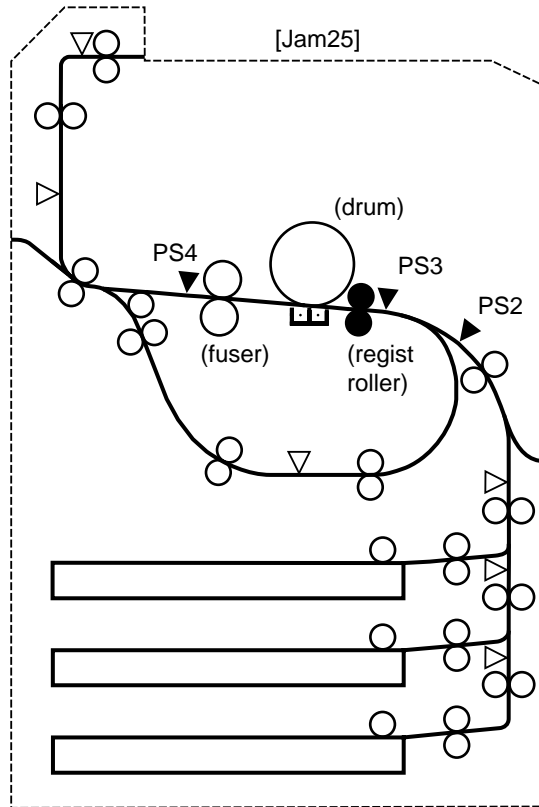

Figure 5-7. Fuser Unit Jam (JAM25) Sensor Locations

Troubleshooting Procedure

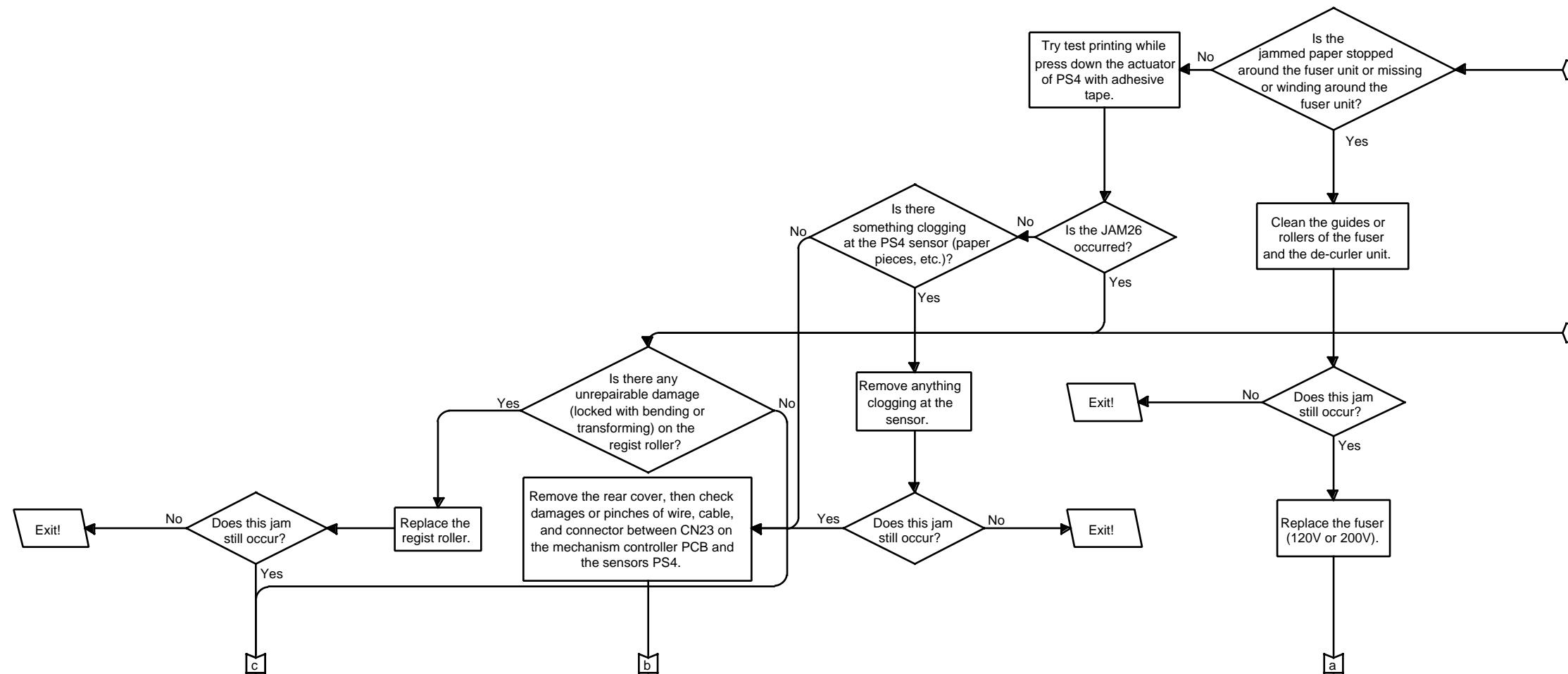

Figure 5-88. JAM25 Fuser Unit Jam Flow Chart (1 of 4)

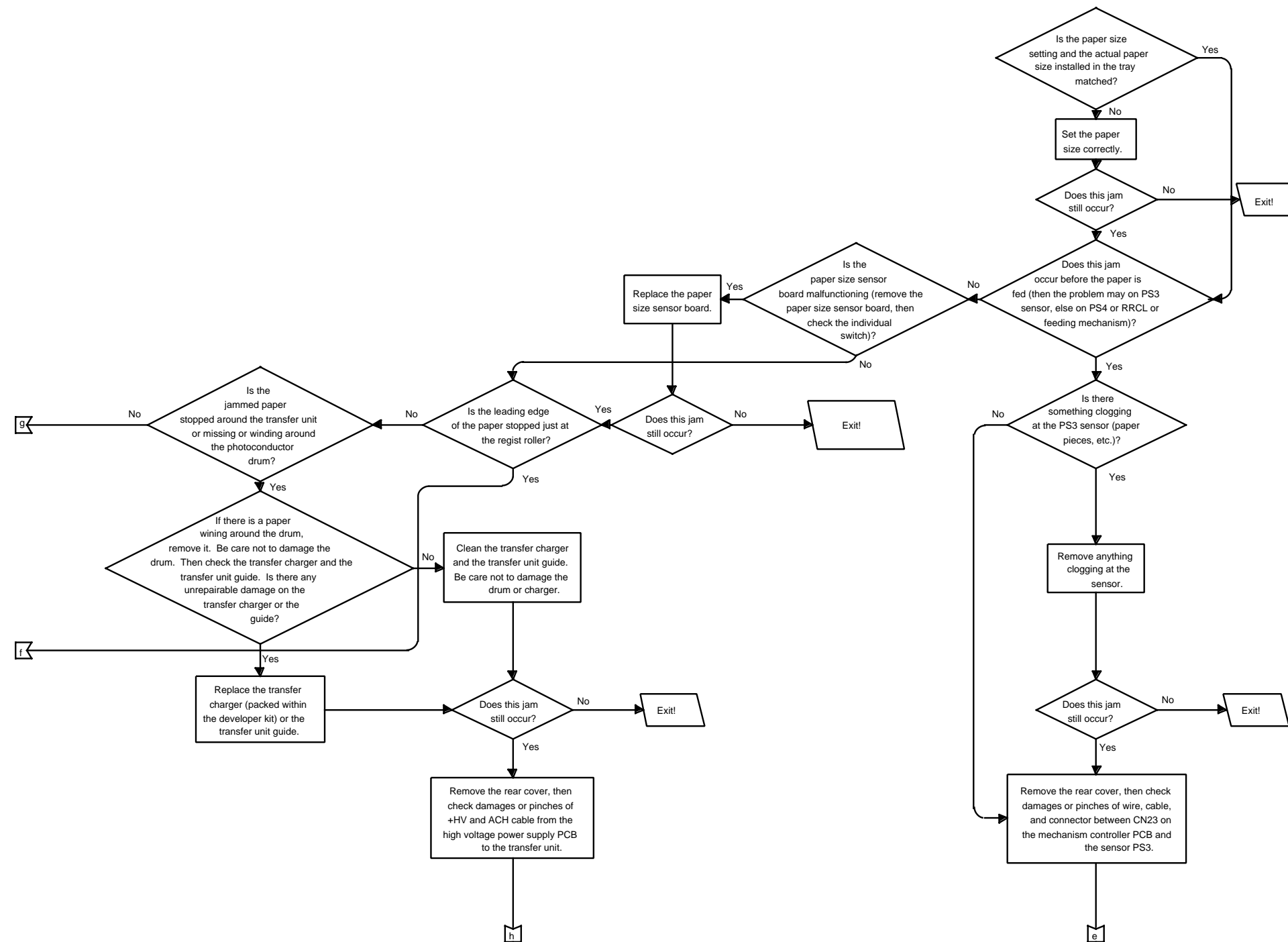

Figure 5-88. JAM25 Fuser Unit Jam Flow Chart (2 of 4)

Troubleshooting Procedure

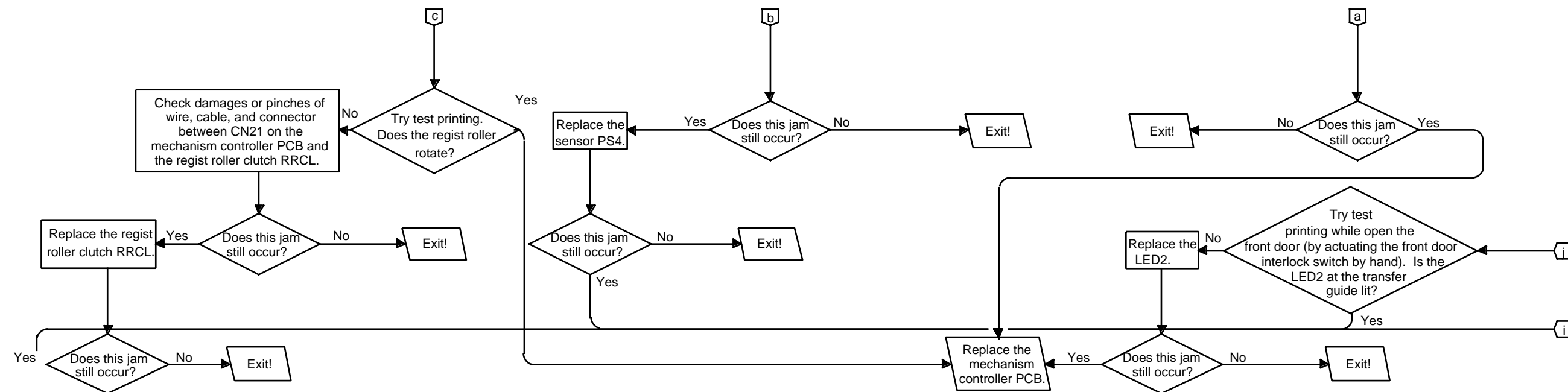

Figure 5-88. JAM25 Fuser Unit Jam Flow Chart (3 of 4)

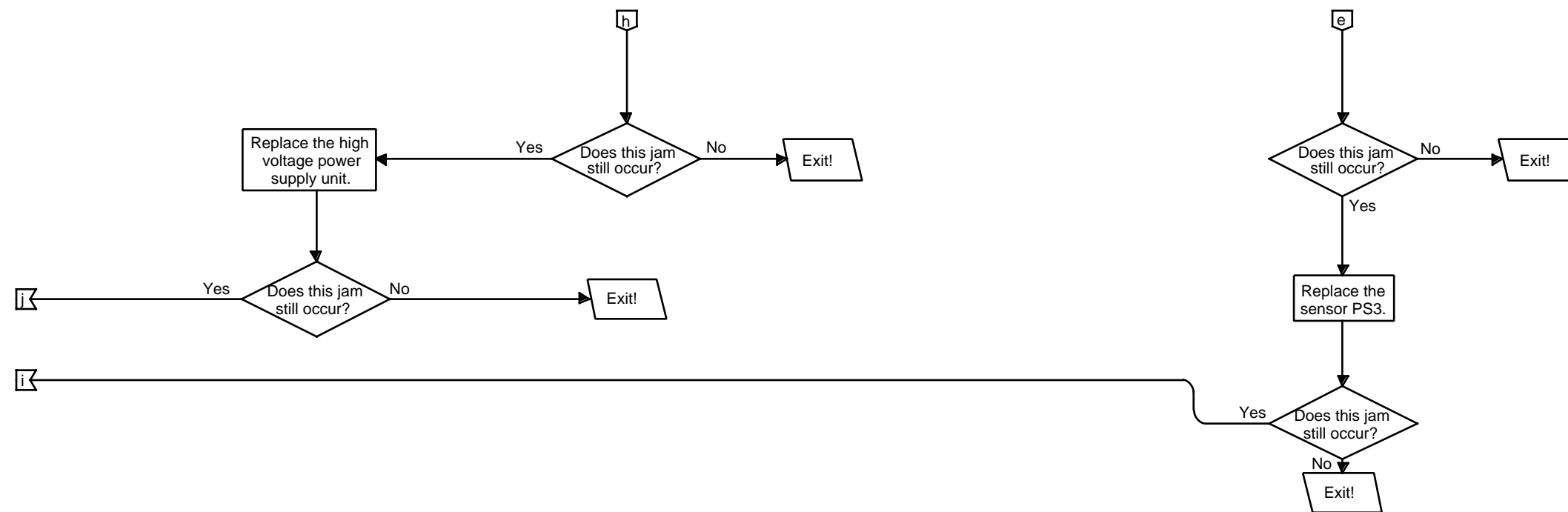

Figure 5-88. JAM25 Fuser Unit Jam Flow Chart (4 of 4)

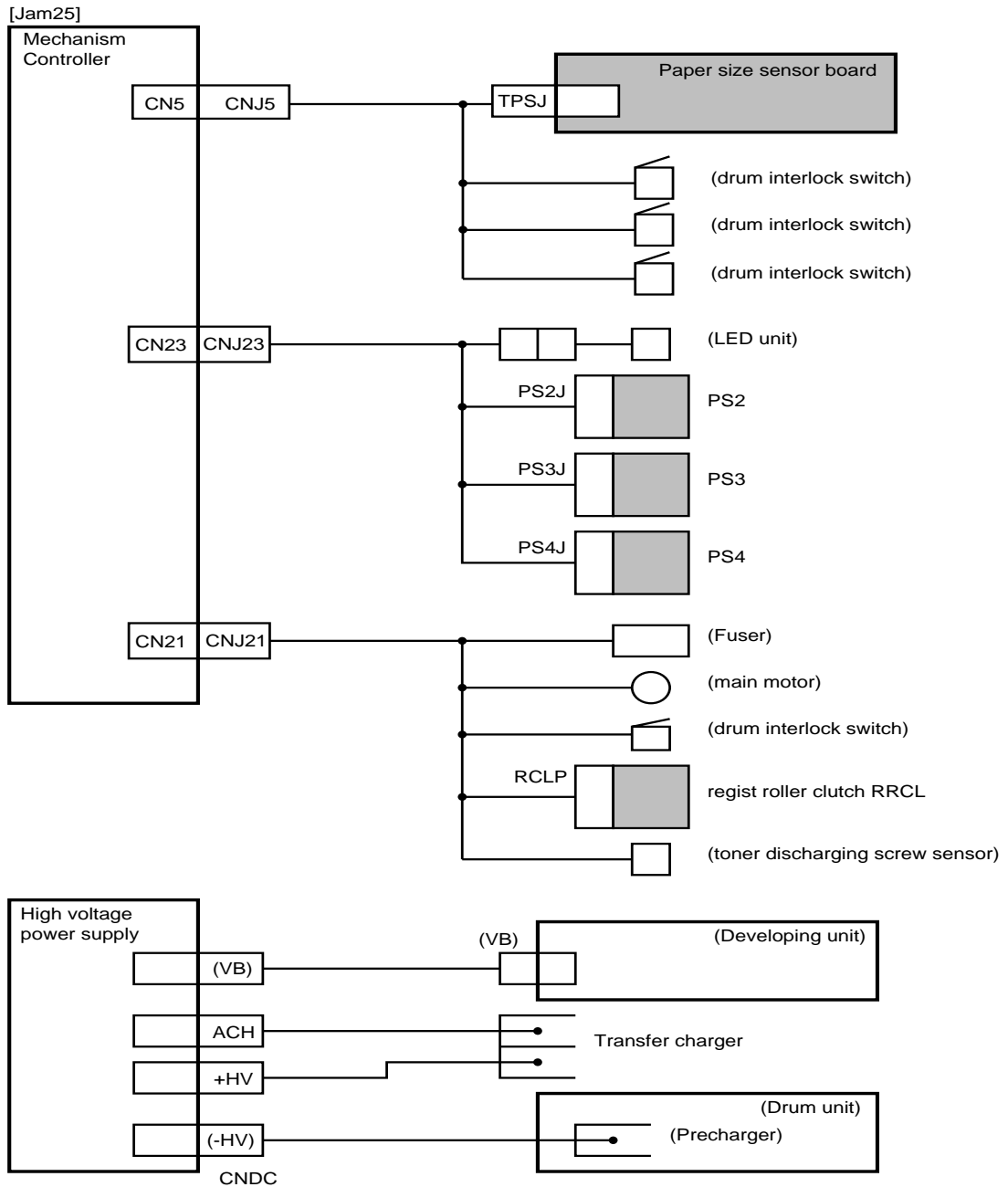

Figure 5-9. Fuser Unit Jam (JAM25) Interconnections Diagram

5-3.5. JAM26/27 Fuser Unit Jam 2**Explanation****Jam26:**

When the printer is reset, there is paper at PS4 sensor at simplex printing, or

The time when paper passed PS4 differs from the standard time specified by paper size at simplex printing.

Jam27:

When the printer is reset, there is paper at PS4 sensor at duplex printing, or

The time when paper passed PS4 differs from the standard time specified by paper size at duplex printing.

Troubleshooting Procedure

<010> Does this jam occur before the paper is fed? (then the problem may on PS4 sensor, else on feeding mechanism) <Y:020, N:100>

<020> Is there something clogging at the PS4 sensor (paper pieces, etc.)? <Y:022, N:030>

<022> Remove anything clogging at the sensor.

<024> Does this jam still occur? <Y:030, N:Exit>

<030> Remove the rear cover, then check damages or pinches of wire, cable, and connector between CN23 on the mechanism controller PCB and the sensors PS4.

<032> Does this jam still occur? <Y:040, N:Exit>

<040> Replace the sensor PS4.

<042> Does this jam still occur? <Y:300, N:Exit>

<100> Is the leading edge of the paper stopped just at the regist roller? <Y:110, N:200>

<110> Is there any unrepairable damage (locked with bending or transforming) on the regist roller? <Y:112, N:120>

<112> Replace the regist roller.

<114> Does this jam still occur? <Y:260, N:Exit>

<120> Try test printing. Does the regist roller rotate? <Y:300, N:122>

<122> Replace the regist roller clutch RRCL.

<124> Does this jam still occur? <Y:300, N:Exit>

<200> Is the jammed paper stopped around the transfer unit or missing or winding around the photoconductor drum? <Y:210, N:250>

<210> If there is a paper winding around the drum, remove it. Be care not to damage the drum. Then check the transfer charger and the transfer unit guide. Is there any unrepairable damage on the transfer charger or the guide? <Y:212, N:214>

<212> Replace the transfer charger (packed within the developer kit: CA81218-E006, fig.7-2) or the transfer unit guide.

<213> Go to 216.

<214> Clean the transfer charger and the transfer unit guide. Be care not to damage the drum or charger.

<216> Does this jam still occur? <Y:220, N:Exit>

<220> Remove the rear cover, then check damages or pinches of +HV and ACH cable from the high voltage power supply PCB to the transfer unit.

<222> Does this jam still occur? <Y:230, N:Exit>

<230> Replace the high voltage power supply unit.

<232> Does this jam still occur? <Y:300, N:Exit>

<250> Clean the guides or rollers of the fuser and the de-curler unit.

<252> Does this jam still occur? <Y:260, N:Exit>

<260> Replace the fuser.

<262> Does this jam still occur? <Y:300, N:Exit>

<300> Replace the mechanism controller PCB.

Reference Diagrams

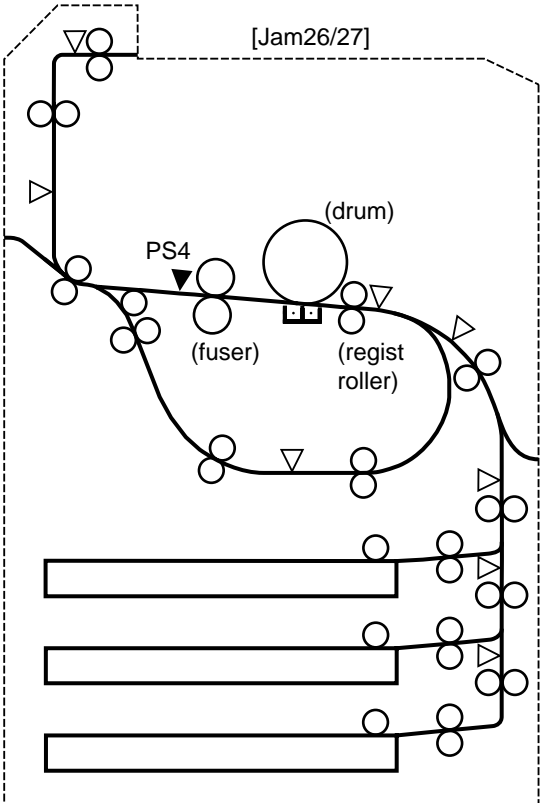

Figure 5-0. Fuser Unit Jam (JAM26/27) Sensor Locations

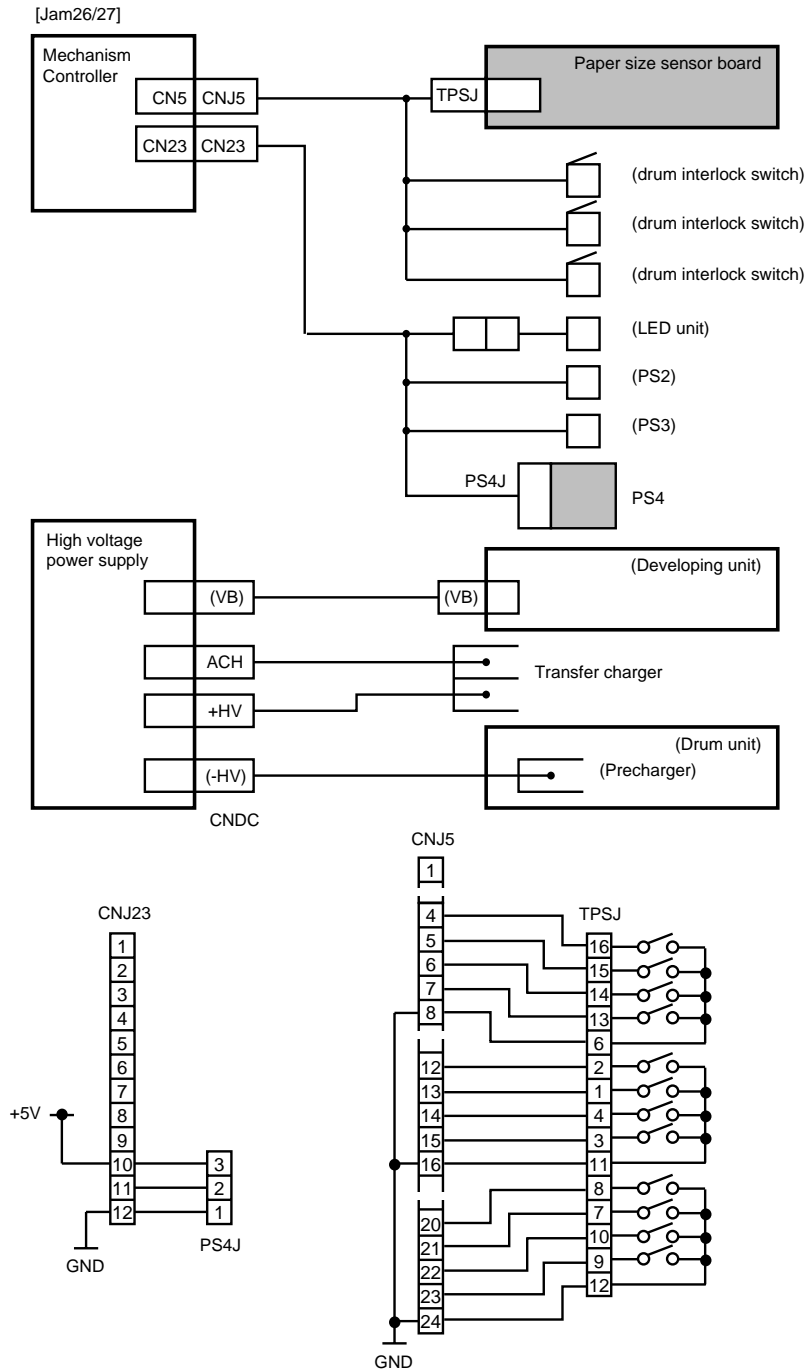

Figure 5-1. Fuser Unit Jam (JAM26/27) Interconnections Diagram

5-3.6. JAM29 Ejection Unit Jam 1

Explanation

Paper did not reach PS6 sensor before specified time passed after the paper reached PS4.

Troubleshooting Procedure

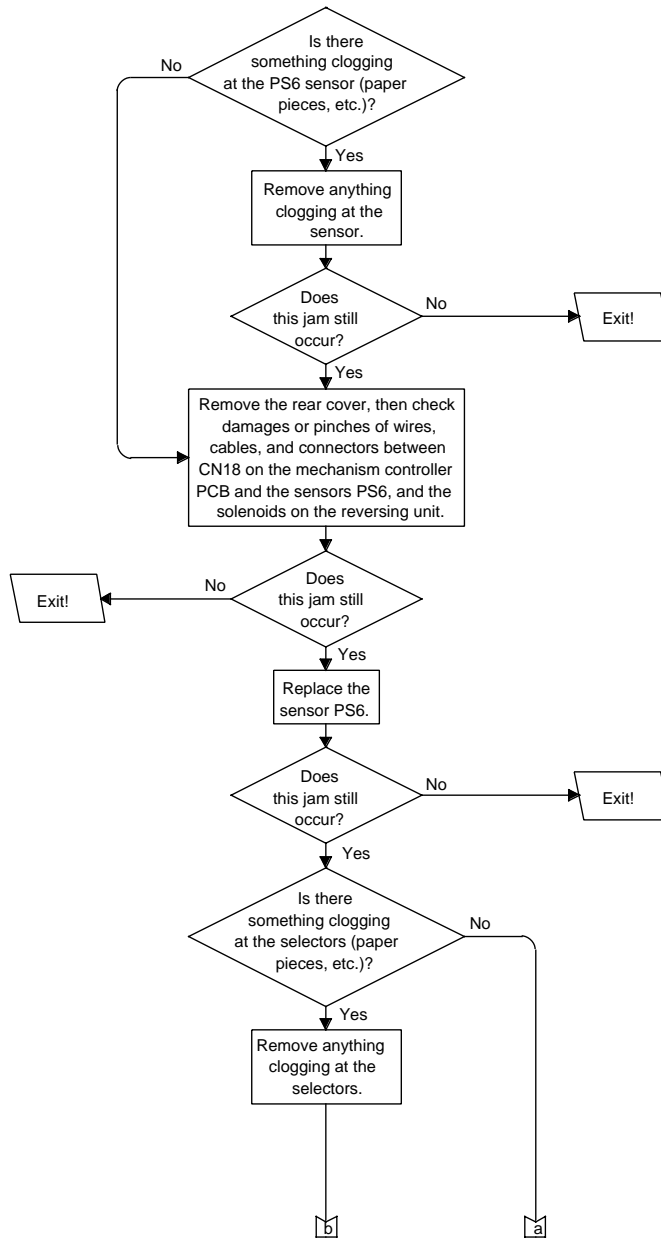

Figure 5-2. JAM29 Ejection Unit Jam (1 of 4)

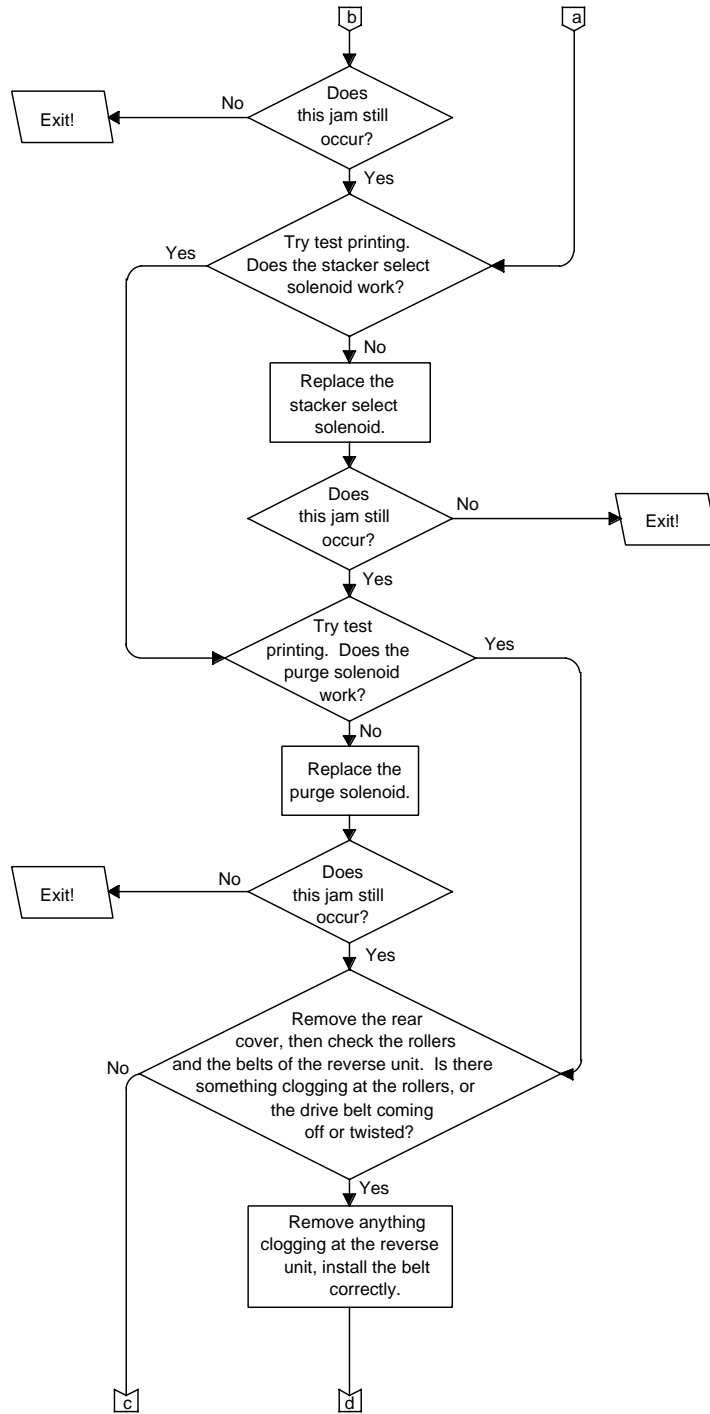

Figure 5-2. JAM29 Ejection Unit Jam (2 of 4)

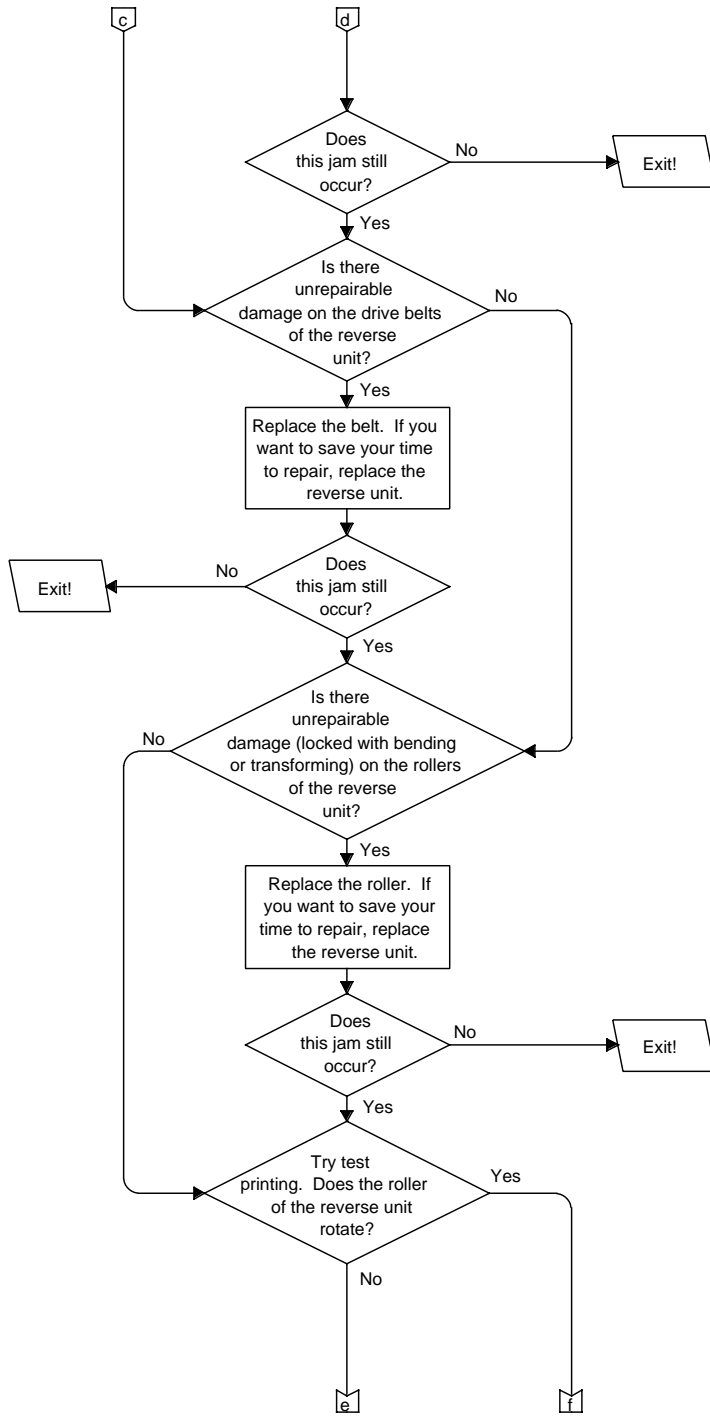

Figure 5-2. JAM29 Ejection Unit Jam (3 of 4)

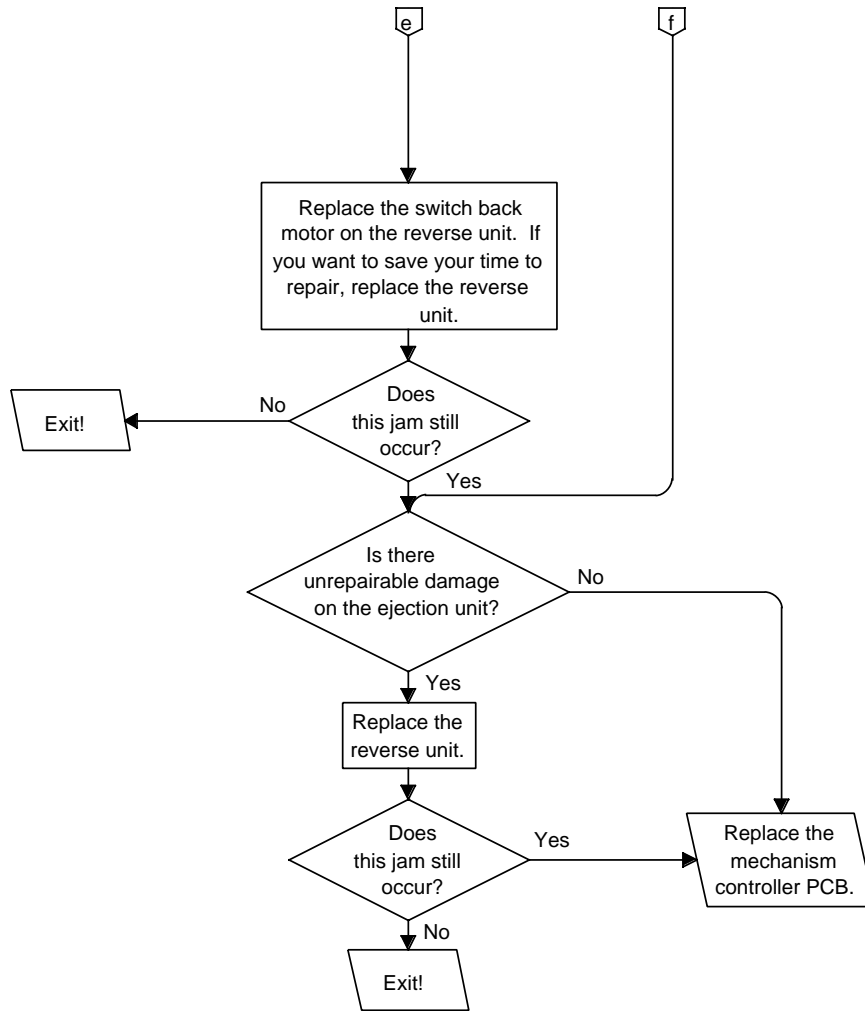

Figure 5-2. JAM29 Ejection Unit Jam (4 of 4)

Reference Diagrams

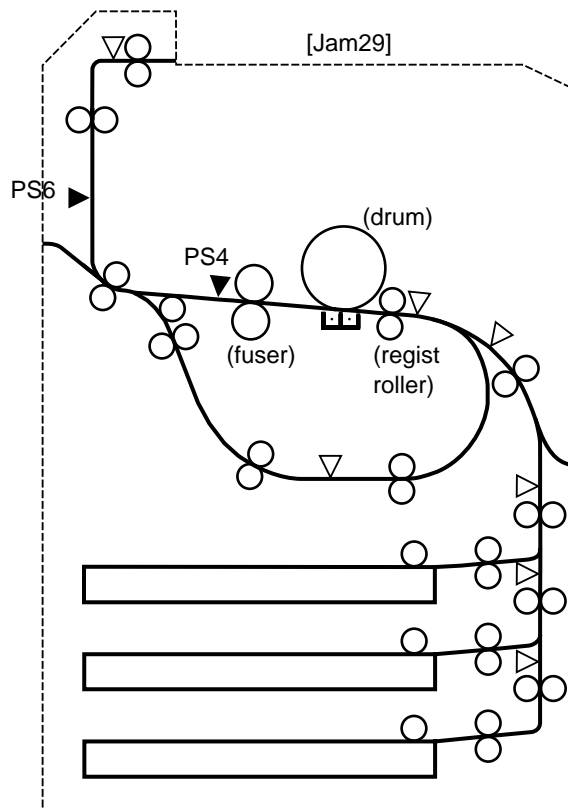

Figure 5-3. Ejection Unit Jam (JAM29) Sensor Locations

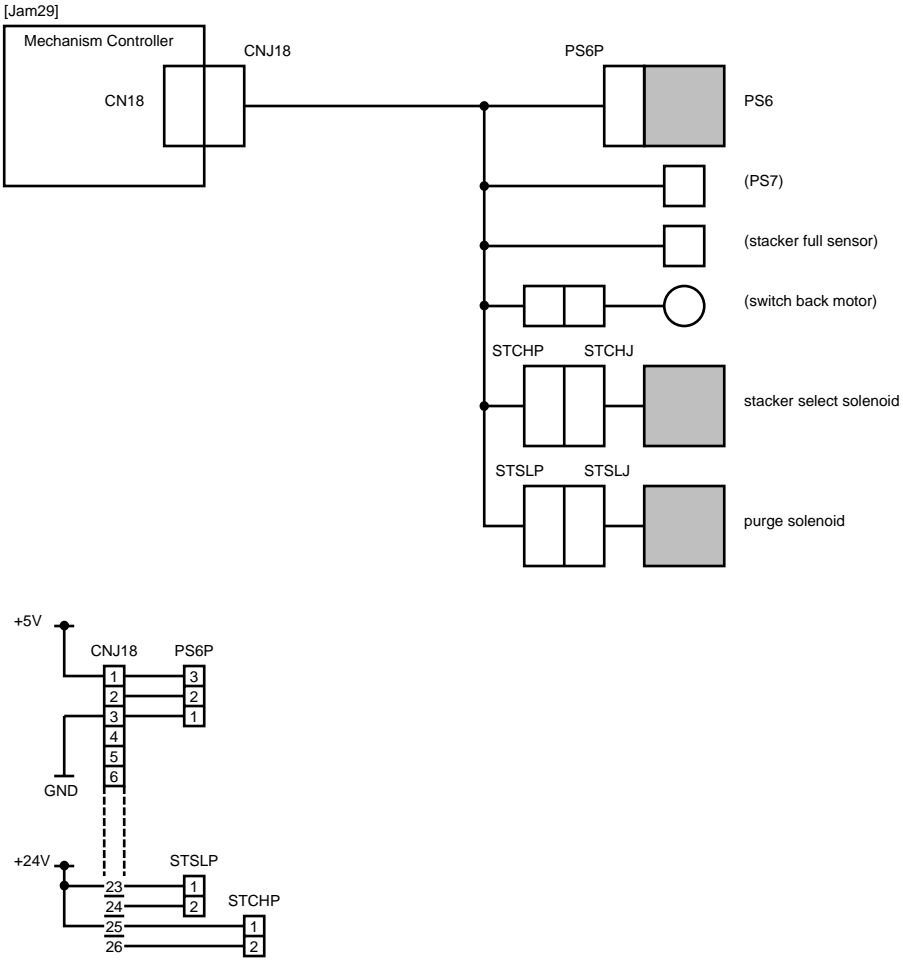

Figure 5-4. Ejection Unit Jam (JAM29) Interconnections Diagram

5-3.7. JAM2B/2C Ejection Unit Jam 2

Explanation

Jam2B:

When the printer is reset, there is paper at PS7 sensor at simplex printing, or

Paper did not reach PS7 sensor before specified time passed after the paper reached PS6 at simplex printing.

Jam2C:

When the printer is reset, there is paper at PS7 sensor at duplex printing, or

Paper did not reach PS7 sensor before specified time passed after the paper reached PS6 at duplex printing.

Troubleshooting Procedure

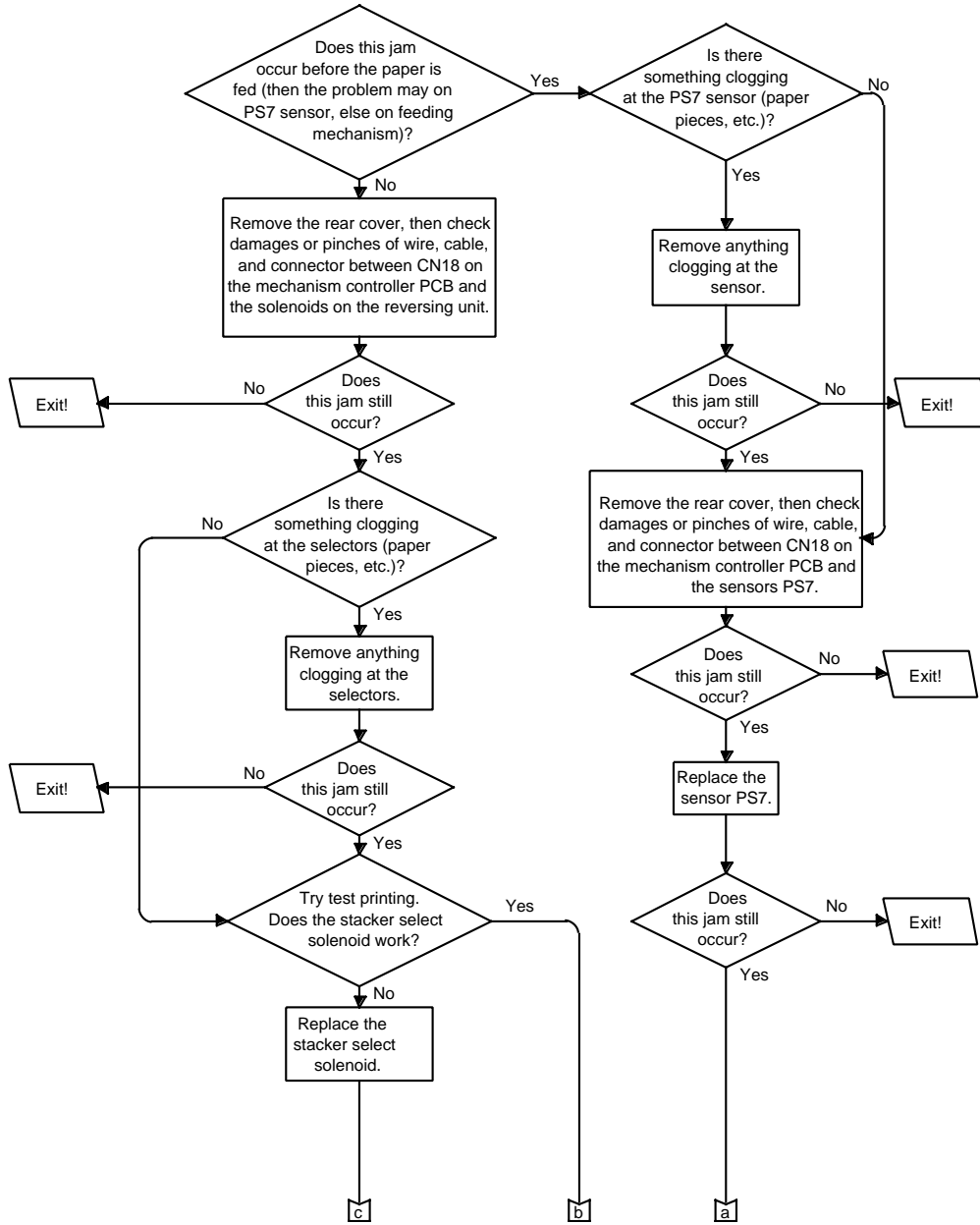

Figure 5-5. JAM2B/2C Ejection Unit Jam Flow Chart (1 of 3)

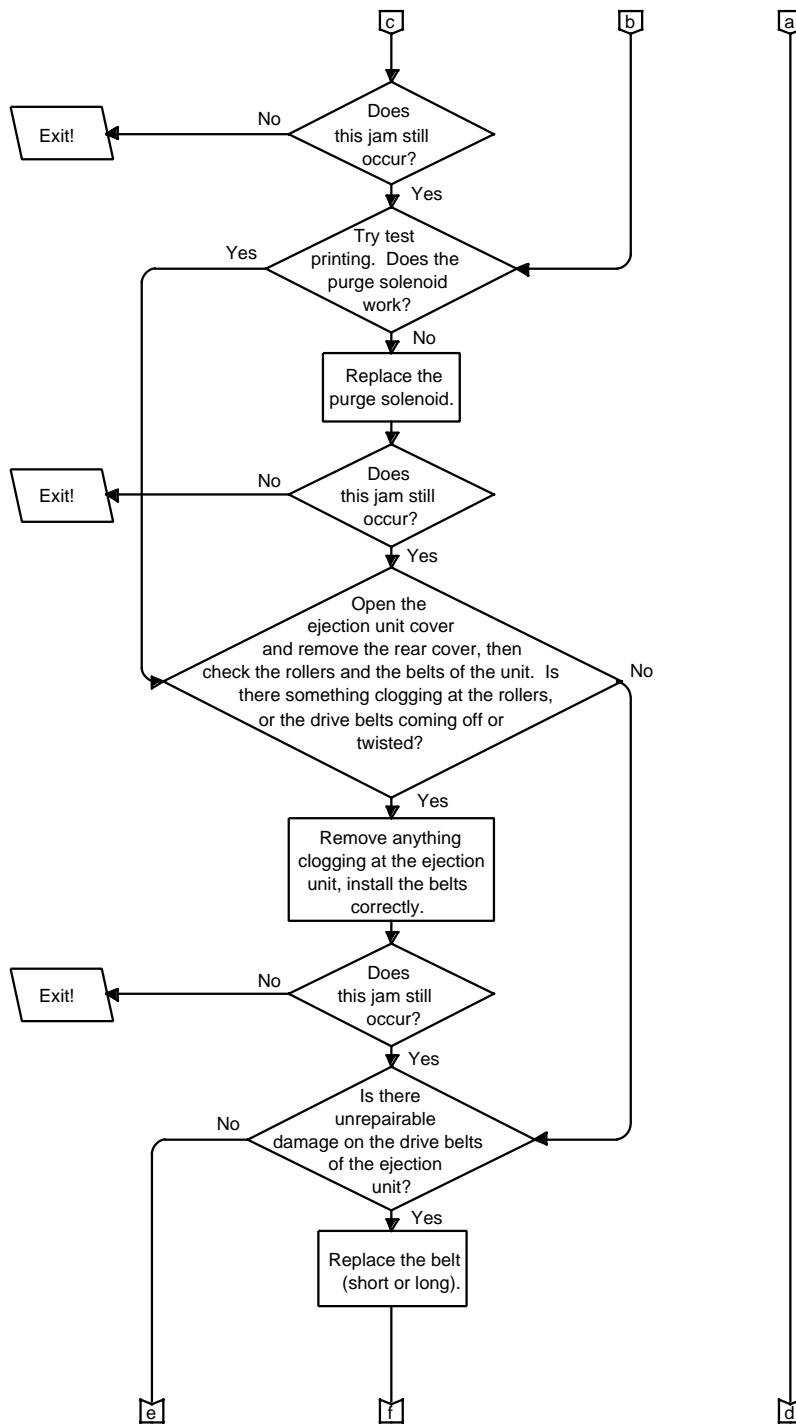

Figure 5-5. JAM2B/2C Ejection Unit Jam Flow Chart (2 of 3)

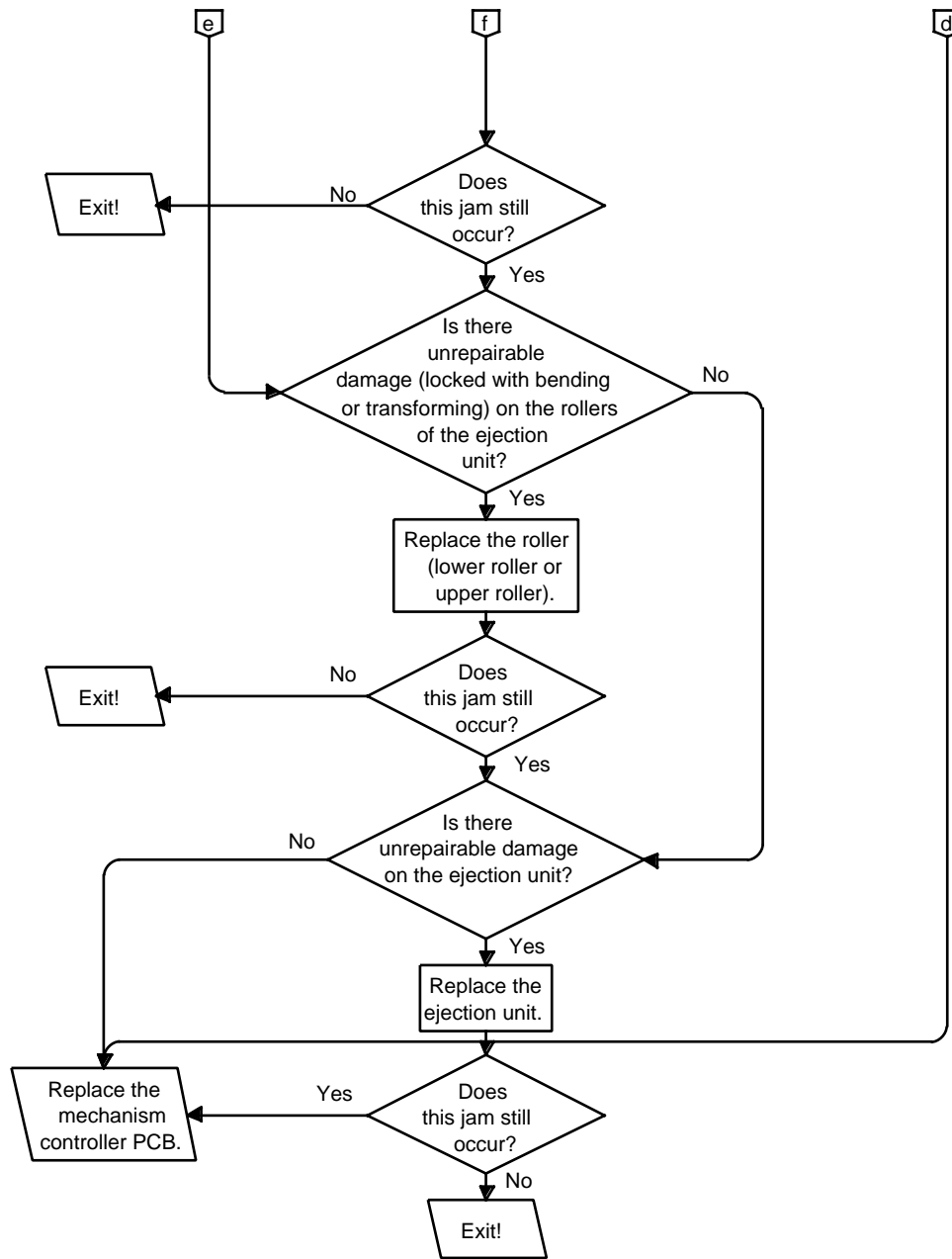

Figure 5-5. JAM2B/2C Ejection Unit Jam Flow Chart (3 of 3)

Reference Diagrams

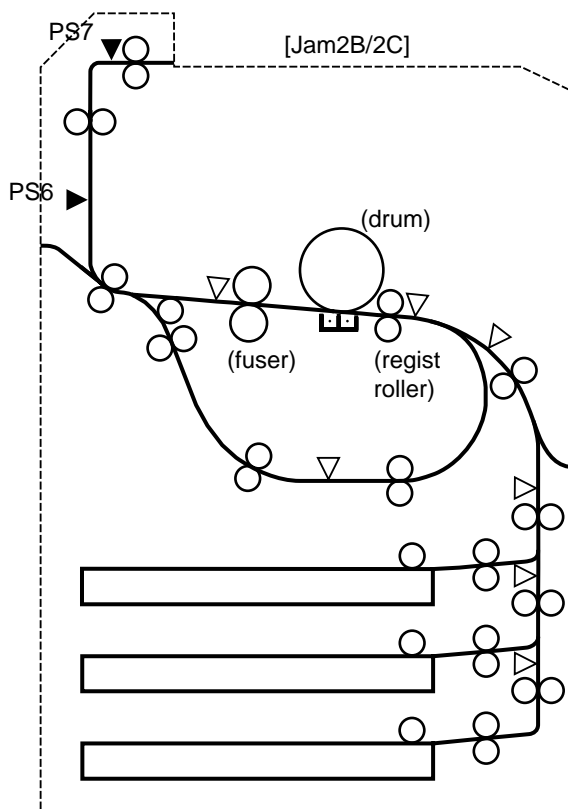

Figure 5-6. Ejection Unit Jam (JAM2B/2C) Sensor Locations

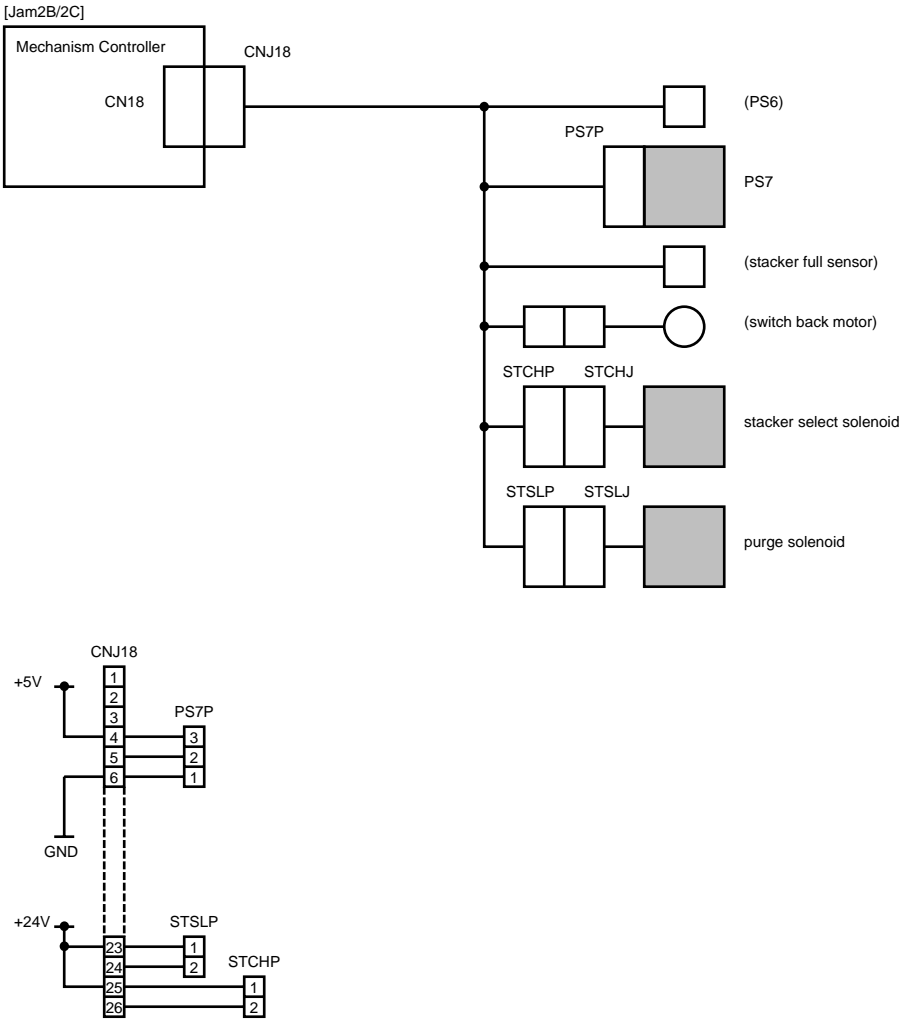

Figure 5-7. Ejection Unit Jam (JAM2B/2C) Interconnections Diagram (1 of 2)

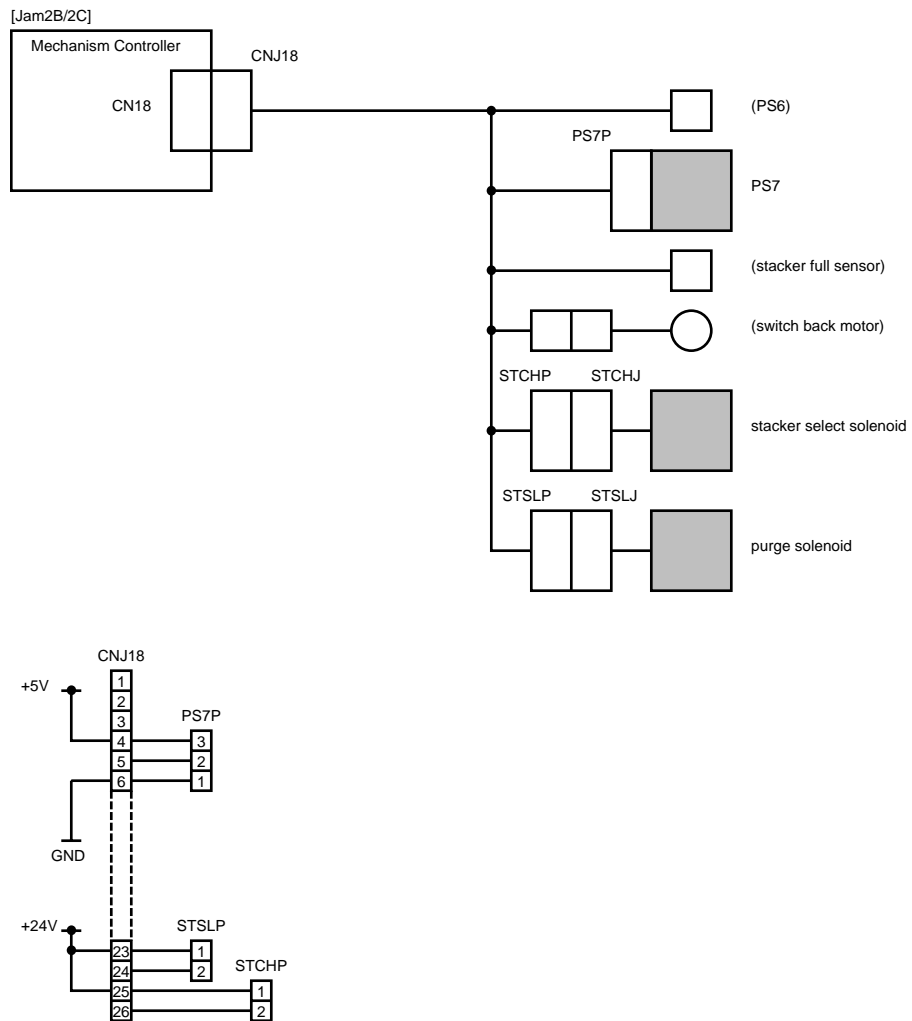

Figure 5-7. Ejection Unit Jam (JAM2B/2C) Interconnections Diagram (2 of 2)

5-3.8. JAM31 Duplex Printing Path Jam 1

Explanation

Paper did not reach PS5 sensor before specified time passed after the switch back motor (SBM) on the duplex unit was set.

Troubleshooting Procedure

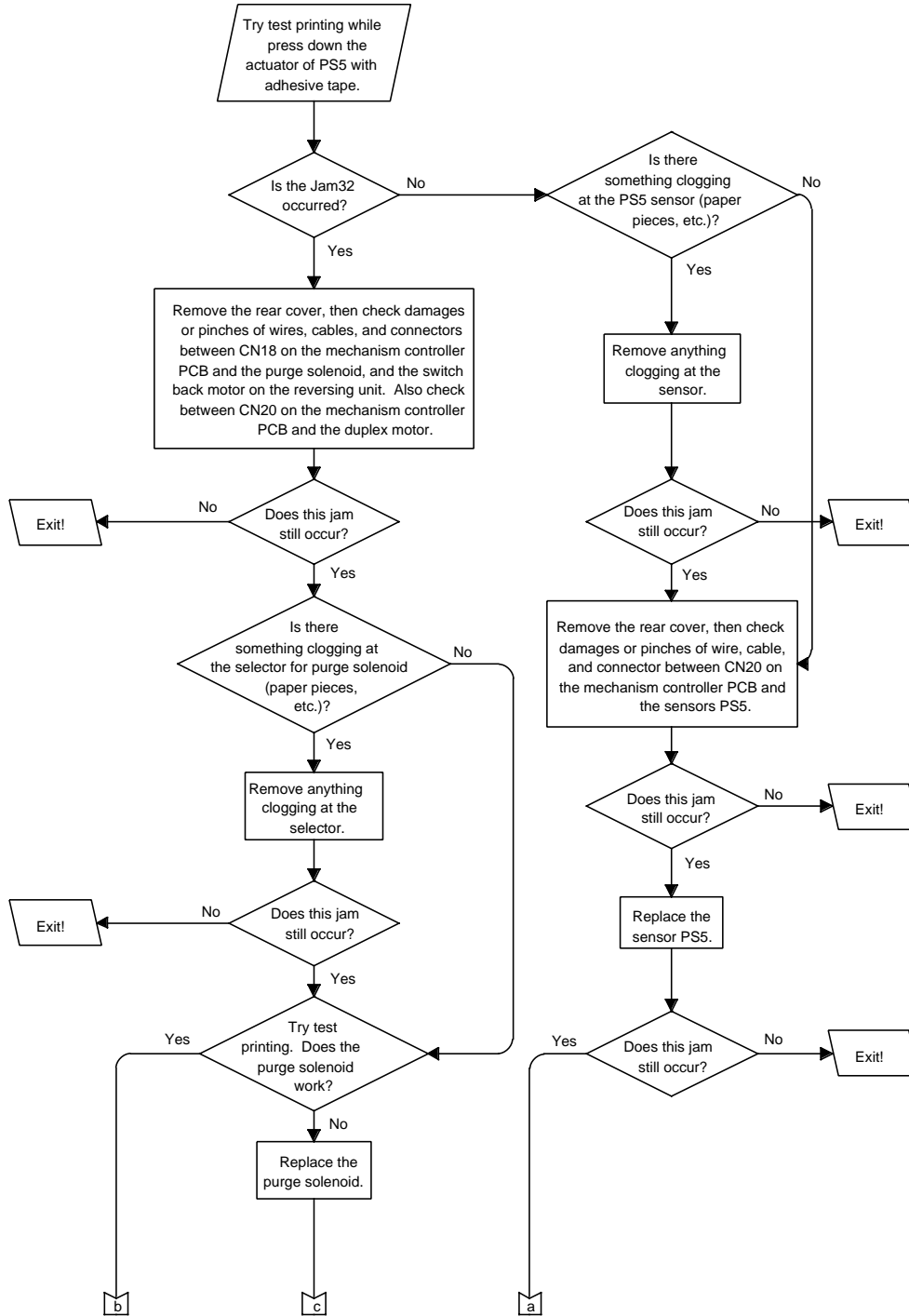

Figure 5-8. JAM31 Duplex Printing Path Jam Flow Chart (1 of 5)

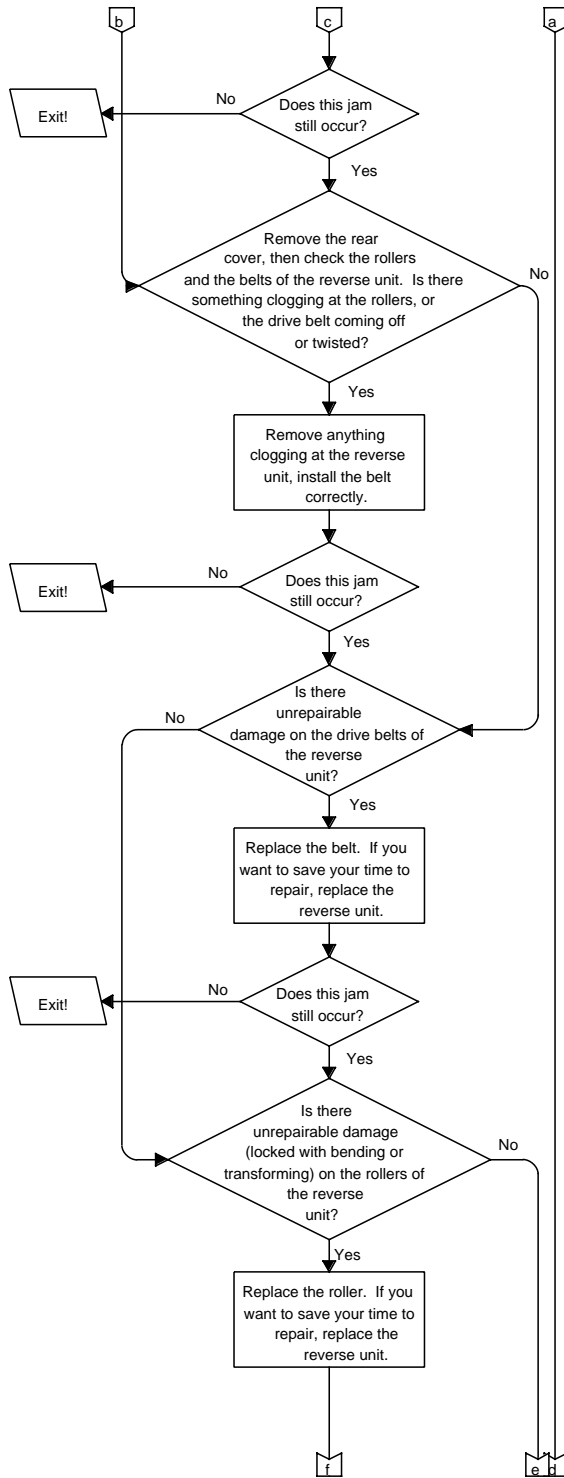

Figure 5-8. JAM31 Duplex Printing Path Jam Flow Chart (2 of 5)

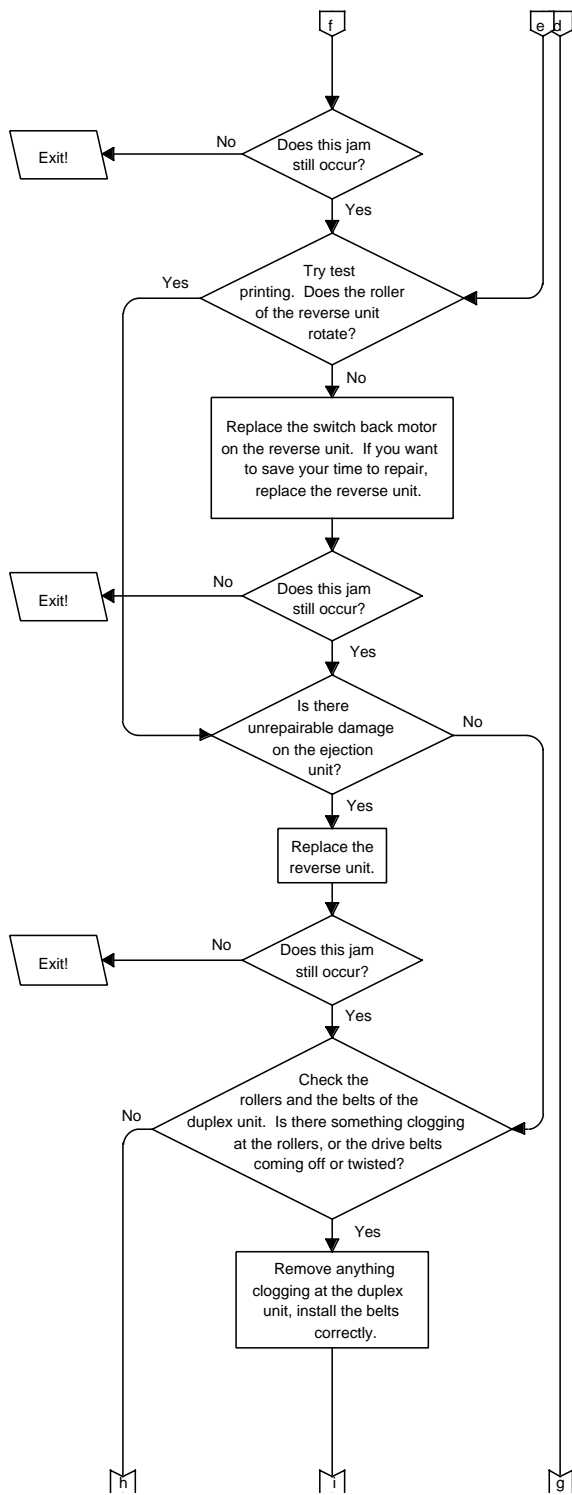

Figure 5-8. JAM31 Duplex Printing Path Jam Flow Chart (3 of 5)

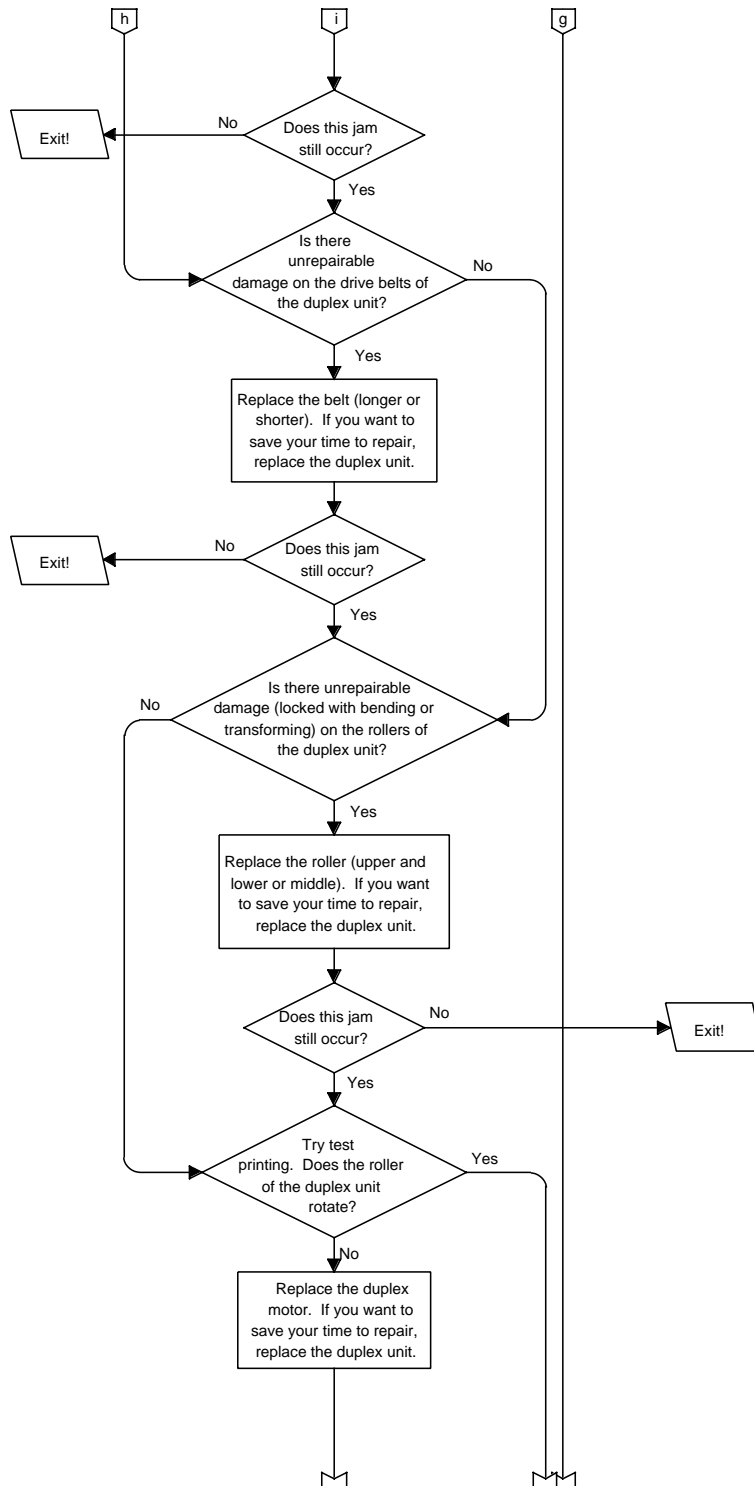

Figure 5-8. JAM31 Duplex Printing Path Jam Flow Chart (4 of 5)

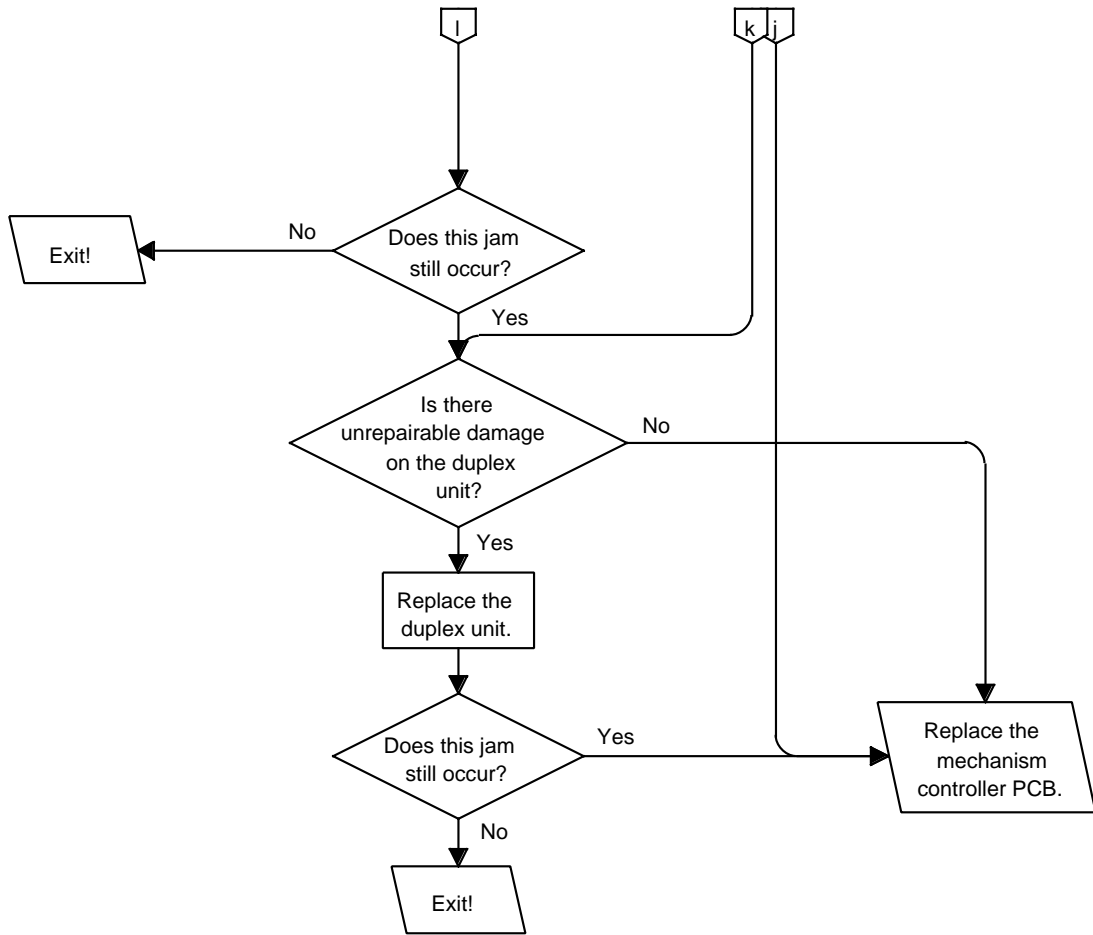

Figure 5-8. JAM31 Duplex Printing Path Jam Flow Chart (5 of 5)

Reference Diagrams

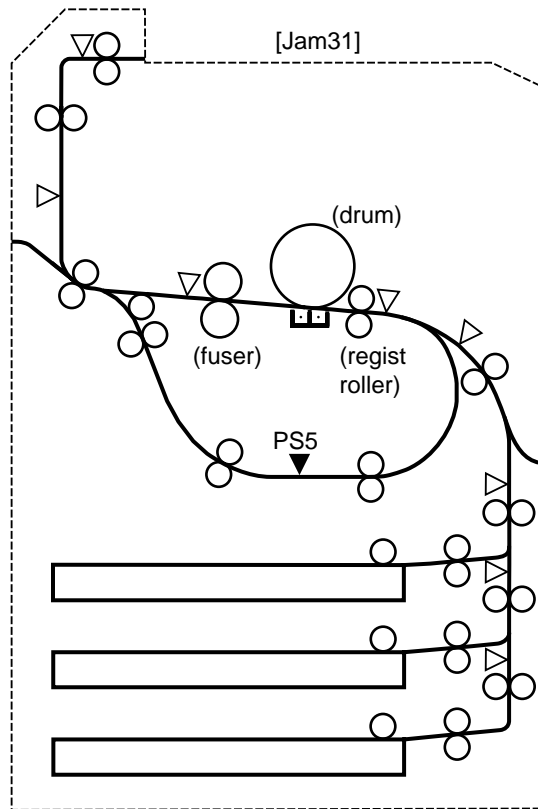

Figure 5-9. Duplex Printing Path Jam (JAM31) Sensor Locations

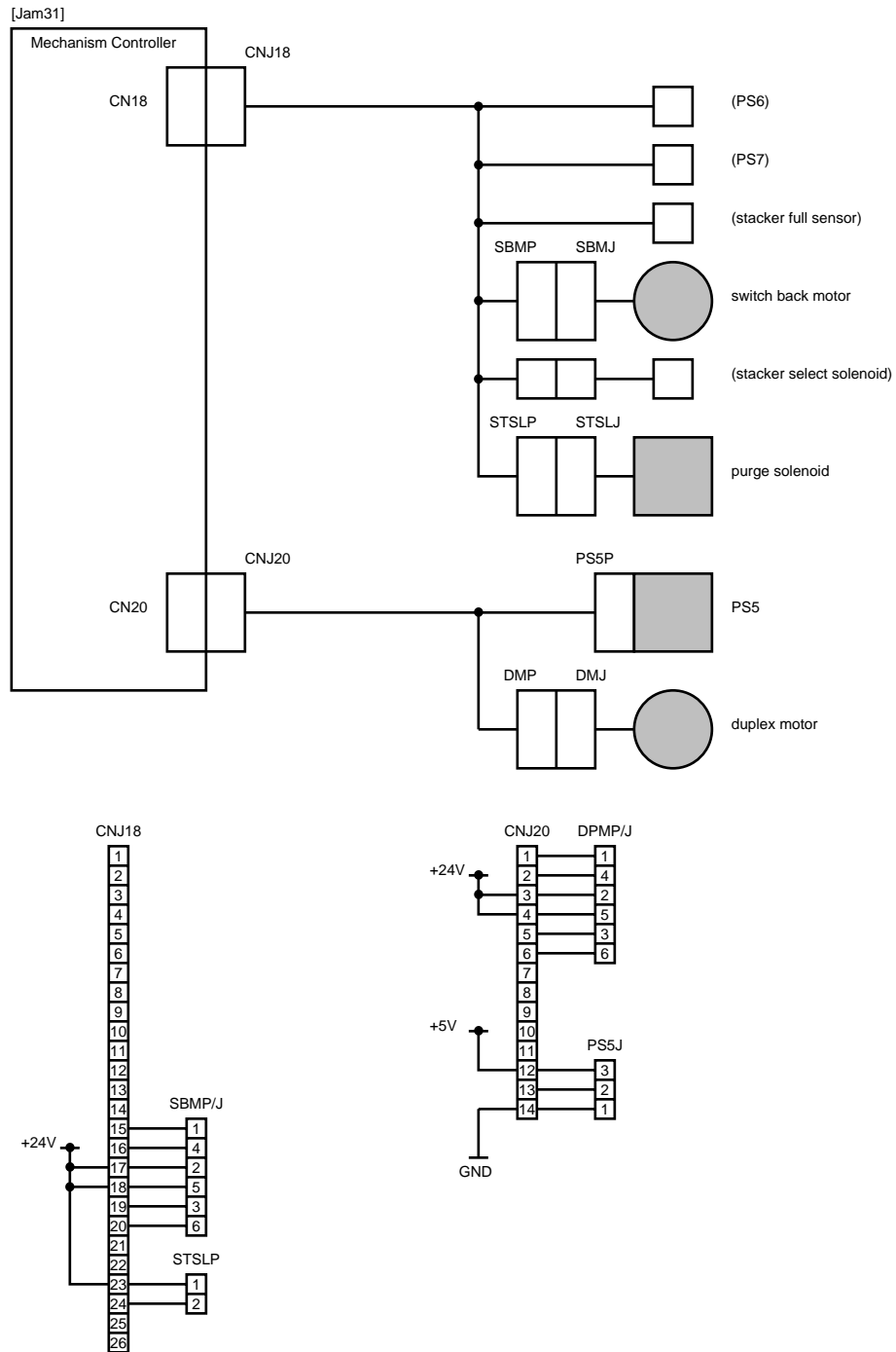

Figure 5-10. Duplex Printing Path Jam (JAM31) Interconnections Diagram

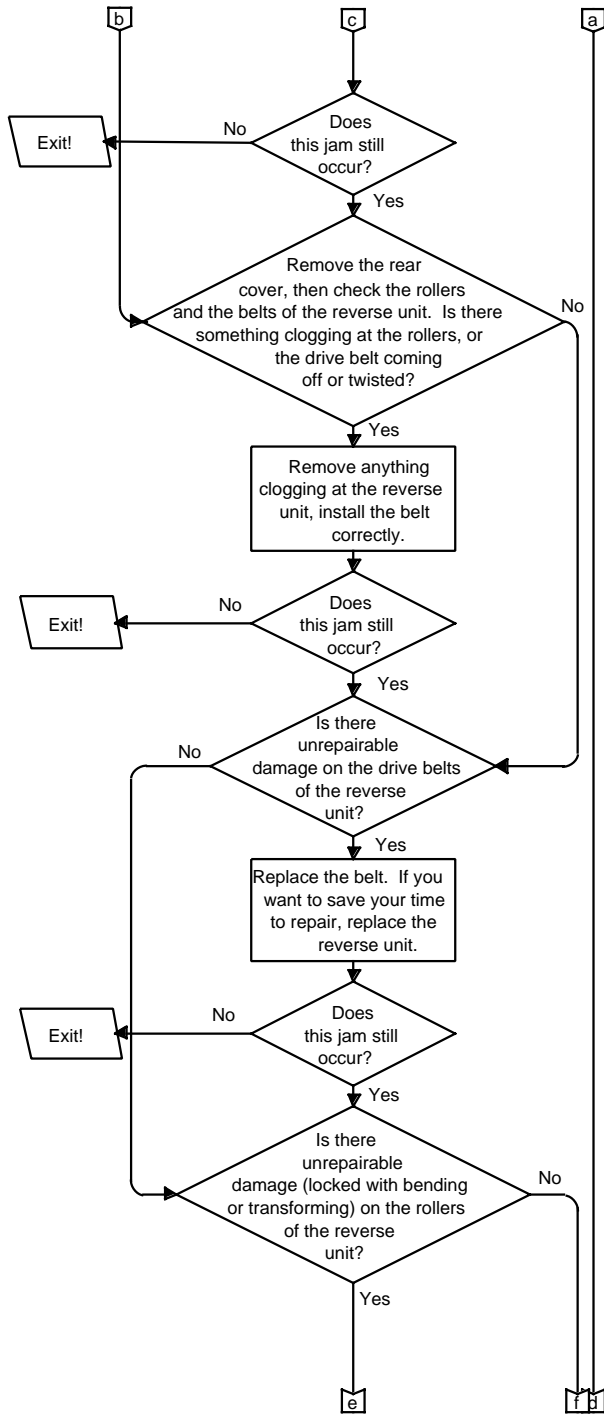

Figure 5-11. JAM32 Duplex Printing Path Jam Flow Chart (2 of 5)

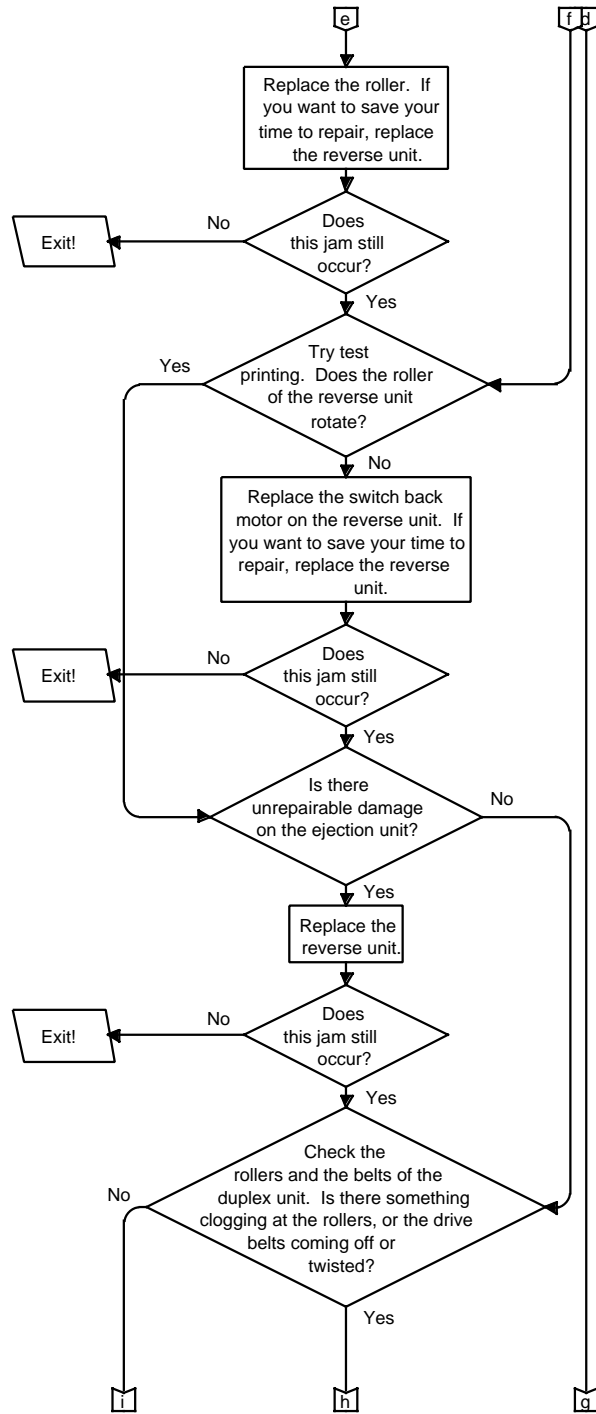

Figure 5-11. JAM32 Duplex Printing Path Jam Flow Chart (3 of 5)

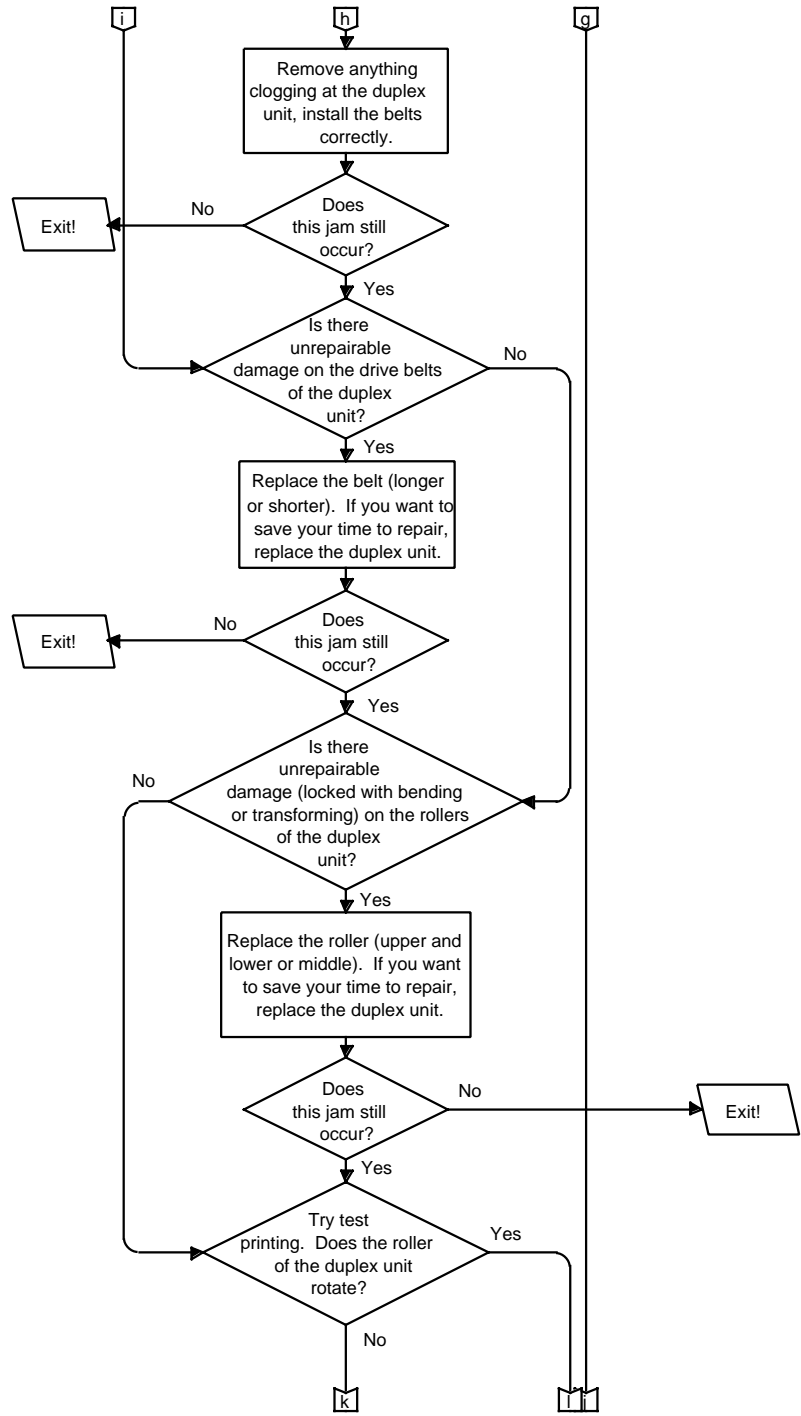

Figure 5-11. JAM32 Duplex Printing Path Jam Flow Chart (4 of 5)

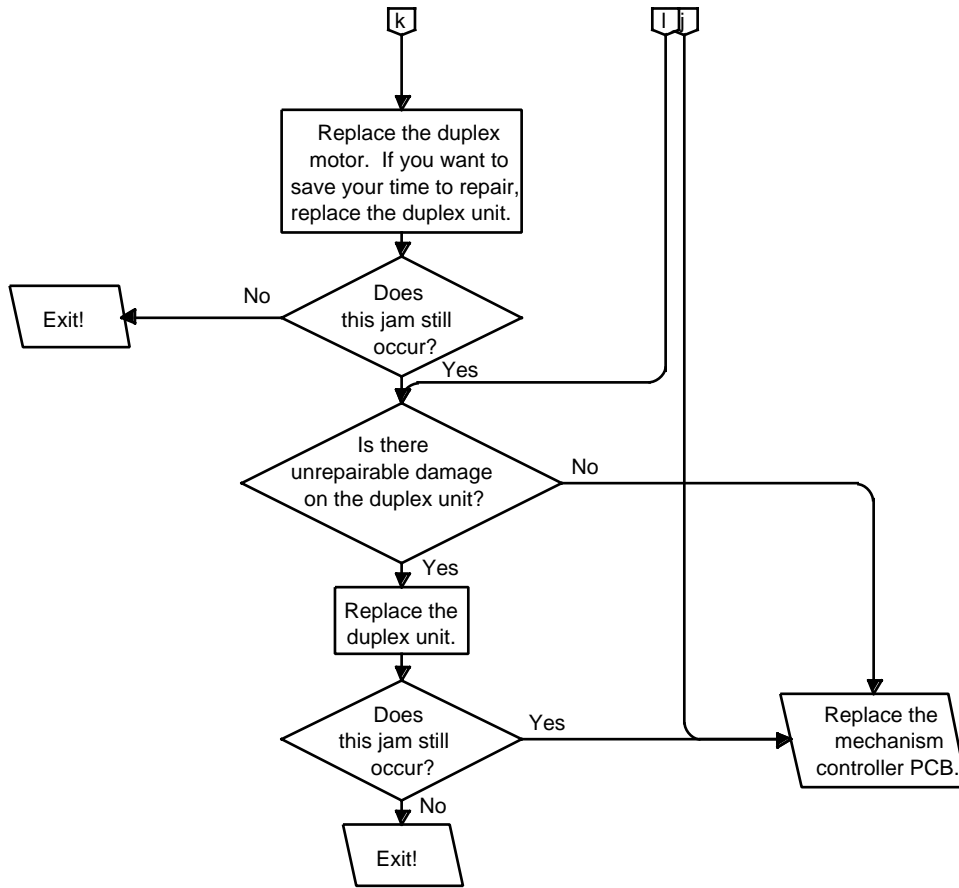

Figure 5-11. JAM32 Duplex Printing Path Jam Flow Chart (5 of 5)

Reference Diagrams

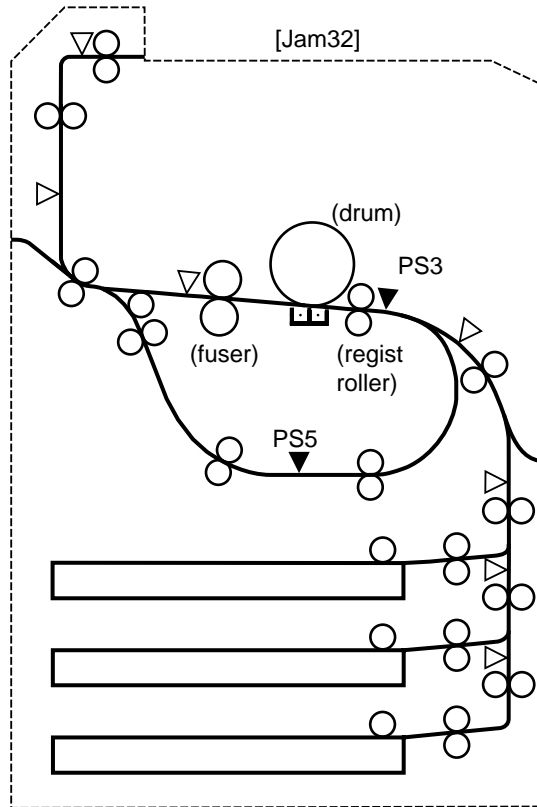

Figure 5-12. Duplex Printing Path Jam (JAM32) Sensor Locations

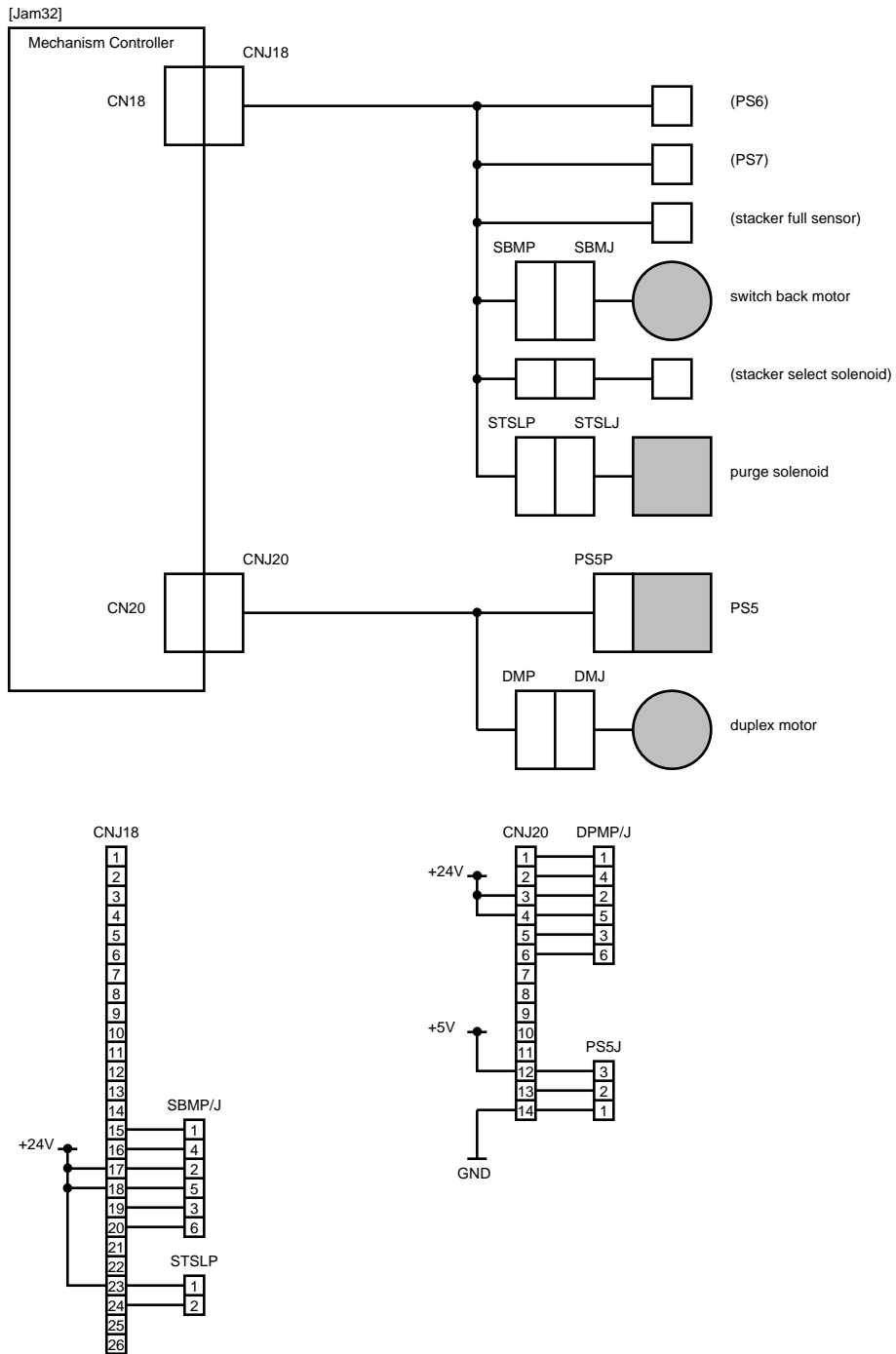

Figure 5-13. Duplex Printing Path Jam (JAM32) Interconnections Diagram

5-4. Power Related Problems

5-4.1. Cannot Power Printer Mechanism or Controls ON

Explanation

The printer can not be turned on, also the back-light of the operator panel is not lit up.

Troubleshooting Flowchart

<010> Check the power cable and the circuit breaker. Is the power cable connected to appropriate AC voltage power outlet correctly? <Y:020, N:012>

<012> Turn on the circuit breaker, and connect the power cable correctly.

<014> Is the printer still unable to turn on? <Y:020, N:Exit>

<020> Is the main switch of the printer set on? <Y:030, N:022>

<022> Turn the main switch on.

<024> Is the printer still unable to turn on? <Y:030, N:Exit>

<030> Remove the rear cover, then check the two LEDs on the power supply PCB and the relay RL1 on the rear frame of the printer.

<040> Is the POWALM LED lit? When this LED is lit, the overcurrent on +5V (except the circuits supplied through the relay RL1) or +12V or +24V circuits may be occurred. <Y:300, N:050>

<050> Is the FANALM LED lit? When this LED is lit, fan4 (fuser cooling fan on the driving unit M) or fan 5 (power supply cooling fan) may be malfunctioned. <Y:200, N:060>

<060> Is the relay RL1 oscillated like a buzzer? (It may oscillate on about 36Hz. When this relay is buzzed, the overcurrent on +5V circuits supplied through the relay RL1 may be occurred.) <Y:150, N:070>

<070> Check the main switch. Is the main line switch malfunctioned? <Y:072, N:080>

<072> Replace the main switch.

<074> Is the printer still unable to turn on? <Y:080, N:Exit>

<080> Check the stand-by switch. Is the stand-by switch malfunctioned? <Y:082, N:090>

<082> Replace the stand-by switch.

<084> Is the printer still unable to turn on? <Y:090, N:Exit>

<090> Check damages or pinches of cables and connectors between following connectors:

CN3* on the main controller PCB and the signal connector of the operator panel,

CN2* on the main controller PCB and the CN14 on the mechanism controller PCB.

***NOTE: The names of these connectors may be changed by OEM customer.**

<092> Is the printer still unable to turn on? <Y:100, N:Exit>

<100> Are the CN8 and CN9 connectors on the mechanism controller PCB connected changing their places each other? <Y:102, N:110>

<102> Connect CN8 and CN9 correctly.

<104> Is the printer still unable to turn on? <Y:110, N:Exit>

<110> Make short-circuit on pin1 of the CN8 on the mechanism controller PCB with GND. Is the printer still unable to turn on? <Y:500, N:520>

<150> Disconnect the OPPJ connector on the operator panel PCB.

<152> Is the printer still unable to turn on? <Y:160, N:540>

<160> Check damages or pinches of cables and connectors between following connectors:

CN11 on the mechanism controller PCB and OPPJ on the operator panel PCB.

<162> Exit.

<200> Do the fan4 and fan5 rotate just after turn on the printer? (To clear the FANALM, turn the main switch off and wait the LED goes off.) <Y:240, N:210>

<210> Is there something preventing the fan4 or fan5 to rotate? <Y:212, N:220>

<212> Free the fan from anything preventing rotation.

<214> Is the printer still unable to turn on? <Y:220, N:Exit>

<220> Check damages or pinches of wires, cables, and connectors between following connectors, especially for pin1 and pin2 (+24V and GND):

CNFAN1 on the power supply PCB and FAN4P of the fan4,

CNFAN2 on the power supply PCB and FAN5P of the fan5.

<222> Is the printer still unable to turn on? <Y:230, N:Exit>

<230> Replace the fan4 or fan5 (fan4 or fan5).

<232> Is the printer still unable to turn on? <Y:500, N:Exit>

<240> Check damages or pinches of wires, cables, and connectors between following connectors,

especially for pin4 (alarm signal):

CNFAN1 on the power supply PCB and FAN4P of the fan4,

CNFAN2 on the power supply PCB and FAN5P of the fan5.

<242> Is the printer still unable to turn on? <Y:230, N:Exit>

<300> Remove the mechanism controller PCB.

<310> [+5V, RL1] Pull out the CN3 connector on the power supply PCB, then check the resistance between pin1 and pin2 of the cable side (not PCB side) of the CN3. Is the resistance 0.35ohm or less? <Y:312, N:320>

<312> Pull out the “13” labeled terminal from the RL1, then check the resistance between the terminal of the relay (not cable) and GND. Is the resistance 0.35ohm or less? <Y:314, N:316>

<314> Replace the relay RL1.

<315> Exit.

<316> Check damages or pinches of wires, cables, and connectors between following connectors:

CN3 on the power supply PCB and “13” labeled terminal of the RL1.

<317> Exit.

<320> [+5V, main controller] Pull out the CN5 connector on the power supply PCB, then check the resistance between pin1 and pin3, between pin2 and pin3 of the cable side (not PCB side) of the CN5. Is the resistance 0.35ohm or less? <Y:322, N:330>

<322> Pull out the CN1* connector on the main controller PCB, then check the resistance between pin1 and pin3, between pin2 and pin3 of the PCB side (not cable side). Is the resistance 0.35ohm or less? <Y:324, N:326>

*NOTE: The name of this connector may be changed by QMS.

<324> Replace the main controller PCB.

<325> Exit.

<326> Check damages or pinches of wires, cables, and connectors between following connectors:

CN5 on the power supply PCB and CN1 on the main controller PCB.

<327> Exit.

<330> [+5V, hard disk drive unit] Pull out the CN7 connector on the power supply PCB, then check the resistance between pin4 and pin3 of the cable side (not PCB side) of the CN7. Is the resistance 0.35ohm or less? <Y:332, N:340>

<332> Pull out the HDDJ connector on the hard disk drive unit, then check the resistance between

pin4 and pin3 of the drive side (not cable side). Is the resistance 0.35ohm or less? <Y:334, N:336>

<334> Replace the hard disk drive unit.

<335> Exit.

<336> Check damages or pinches of wires, cables, and connectors between following connectors:
CN7 on the power supply PCB and HDDJ on the hard disk drive unit.

<337> Exit.

<340> [+5V, operator panel] Pull out the CN6 connector on the power supply PCB, then check the resistance between pin1 and pin2 of the cable side (not PCB side) of the CN6. Is the resistance 0.35ohm or less? <Y:342, N:350>

<342> Pull out the OPPJ connector on the operator panel PCB, then check the resistance between pin1 and pin2 of the PCB side (not cable side). Is the resistance 0.35ohm or less? <Y:344, N:346>

<344> Go to 540.

<346> Check damages or pinches of wires, cables, and connectors between following connectors:
CN6 on the power supply PCB and OPPJ on the operator panel PCB.

<347> Exit.

<350> [+12V, main controller/hard disk drive unit/primary side of RL2] Pull out the CN7 connector on the power supply PCB, then check the resistance between pin1 and pin2 of the cable side (not PCB side) of the CN7. Is the resistance 3ohm or less? <Y:460, N:360>

<360> [+12V, secondary side of RL2/fan6] Pull out the CN10 connector on the mechanism controller PCB, then check the resistance between pin1 and pin2 of the cable side (not PCB side) of the CN10. Is the resistance 3ohm or less? <Y:420, N:370>

<370> [+12V, toner density sensor] Pull out the CN1 connector on the mechanism controller PCB, then check the resistance between pin2 and pin10 of the cable side (not PCB side) of the CN1. Is the resistance 3ohm or less? <Y:372, N:380>

<372> Pull out the TNSP connector near the developing unit, then check the resistance between pin2 and pin10 of the developing unit side (not cable side). Is the resistance 3ohm or less? <Y:374, N:376>

<374> Replace the developing unit.

<375> Exit.

<376> Check damages or pinches of wires, cables, and connectors between following connectors:
CN1 on the mechanism controller PCB and TNSP near the developing unit.

<377> Exit.

<380> [+24V, optical unit] Pull out the CN3 connector on the power supply PCB, then check the resistance between pin5 and pin4 of the cable side (not PCB side) of the CN3. Is the resistance 2.18ohm or less? <Y:382, N:390>

<382> Check damages or pinches of wires, cables, and connectors between following connectors:
CN3 on the power supply PCB and CN4 on the optical unit.

<384> Connect the CN4 on the optical unit, then check the resistance between pin5 and pin4 of the cable side (not PCB side) of the CN3 on the power supply PCB again. Is the resistance 2.18ohm or less? <Y:386, N:Exit>

<386> Replace the optical unit.

<387> Exit.

<390> [+24V, LCH] If LCH is installed, pull out the CN3 connector on the power supply PCB, then check the resistance between pin6 and pin4 of the cable side (not PCB side) of the CN3. Is the resistance 2.18ohm or less? <Y:392, N:400>

<392> Check damages or pinches of wires, cables, and connectors between following connectors:
CN3 on the power supply PCB and interface connector for the LCH,
interface connector and PW board-A of the LCH.

<394> Connect the LCH as it was, then check the resistance between pin6 and pin4 of the cable side (not PCB side) of the CN3 on the power supply PCB again. Is the resistance 2.18ohm or less?

<Y:396, N:Exit>

<396> Replace the PW board-A.

<397> Exit.

<400> [+24V, high voltage power supply] Pull out the CN3 connector on the mechanism controller PCB, then check the resistance between pin8 and pin7 of the cable side (not PCB side) of the CN3. Is the resistance 2.18ohm or less? <Y:402, N:410>

<402> Pull out the CNDC connector on the high voltage power supply PCB, then check the resistance between pin1 and pin2 of the PCB side (not cable side). Is the resistance 2.18ohm or less? <Y:404, N:406>

<404> Replace the high voltage power supply.

<405> Exit.

<406> Check damages or pinches of wires, cables, and connectors between following connectors:
CN3 on the power supply PCB and CNDC on the high voltage power supply.

<407> Exit.

<410> [+12V, mechanism controller PCB] Check the resistance between pin1 and pin2 of the PCB side (not cable side) of the CN10 on the mechanism controller PCB. Is the resistance 3ohm or less? <Y:520, N:412>

<412> [+24V, mechanism controller PCB] Check the resistance between pin5 and pin4, between pin6 and pin4 of the PCB side (not cable side) of the CN10. Is the resistance 2.18ohm or less? <Y:520, N:500>

<420> [+12V, fan6] Pull out the FAN6P connector of the fan6 (main controller cooling fan).

<430> Check the resistance between pin1 and pin2 of the cable side (not PCB side) of the CN10 on the mechanism controller PCB. Is the resistance 3ohm or less? <Y:440, N:432>

<432> Replace the fan6.

<433> Exit.

<440> [+12V, relay RL2] Pull out the “24” labeled terminal from the relay RL2.

<450> Check the resistance between pin1 and pin2 of the cable side (not PCB side) of the CN10 on the mechanism controller PCB. Is the resistance 3ohm or less? <Y:454, N:452>

<452> Replace the relay RL2.

<453> Exit.

<454> Check damages or pinches of wires, cables, and connectors between following connectors:

CN10 on the mechanism controller PCB and FAN6P of the fan6 above the main controller,

CN10 on the mechanism controller PCB and relay RL2.

<456> Exit.

<460> [+12V, main controller] Pull out the **CN14*** connector on the main controller PCB.

***NOTE: This connector’s name may be changed by OEM Customer.**

<462> Check the resistance between pin1 and pin2 of the cable side (not PCB side) of the CN7 on the power supply PCB. Is the resistance 3ohm or less? <Y:470, N:324>

<470> [+12V, hard disk drive unit] Pull out the HDDJ connector of the hard disk drive unit.

<472> Check the resistance between pin1 and pin2 of the cable side (not PCB side) of the CN7 on the power supply PCB. Is the resistance 3ohm or less? <Y:480, N:334>

<480> [+12V, relay RL2] Pull out the “23” labeled terminal from the relay RL2.

<482> Check the resistance between pin1 and pin2 of the cable side (not PCB side) of the CN7 on the power supply PCB. Is the resistance 3ohm or less? <Y:486, N:452>

<486> Check damages or pinches of wires, cables, and connectors between following connectors:

CN7 on the power supply PCB and relay RL2,

CN7 on the power supply PCB and CN14 on the main controller PCB,

CN7 on the power supply PCB and HDDJ of the hard disk drive unit.

<488> Exit.

<500> Replace the power supply PCB.

<502> Exit.

<520> Replace the mechanism controller PCB.

<522> Exit.

<540> Replace the operator panel.

<542> Exit.

Reference Diagrams

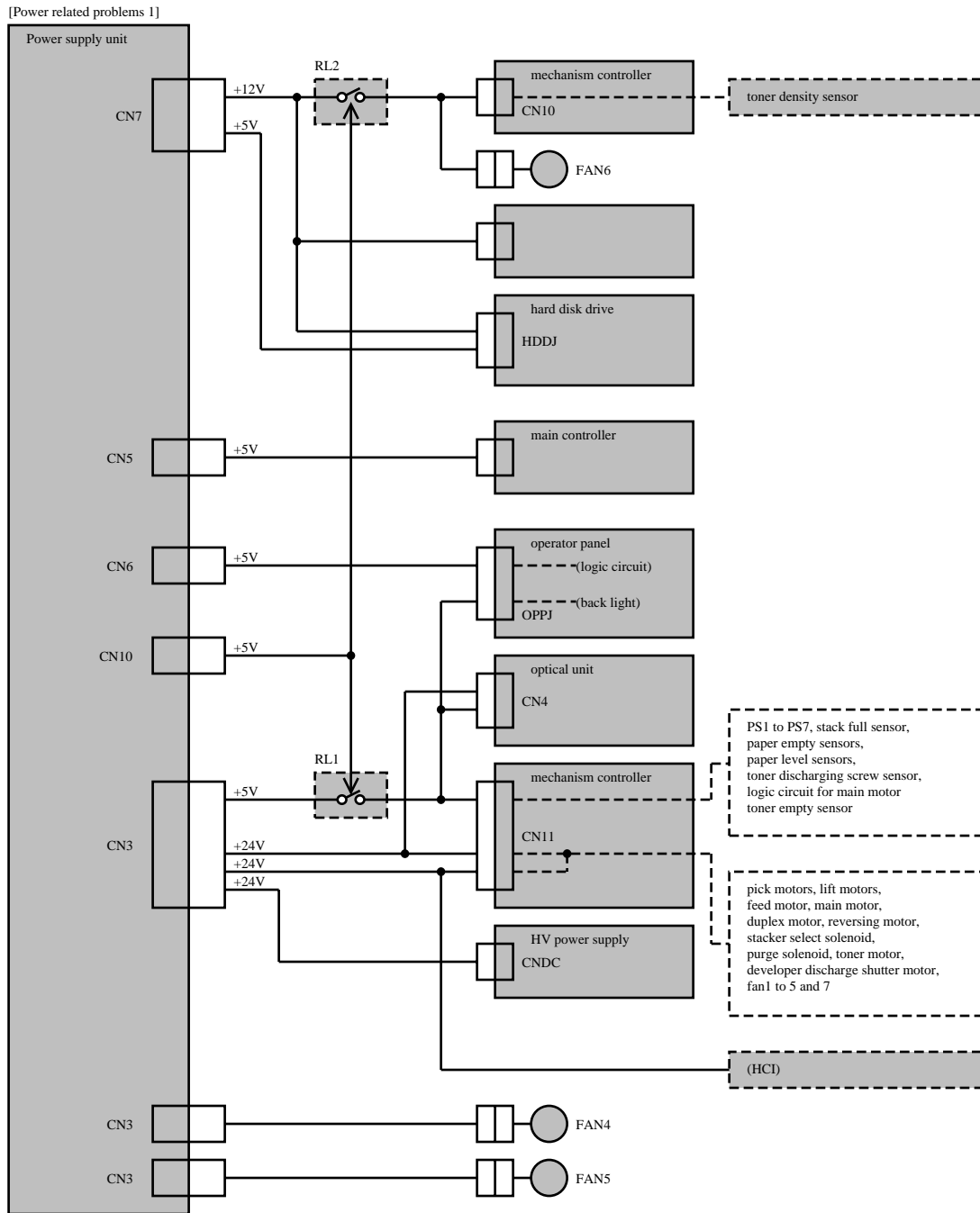

Figure 5-14. Power Control 1 Interconnections Diagram (1 of 2)

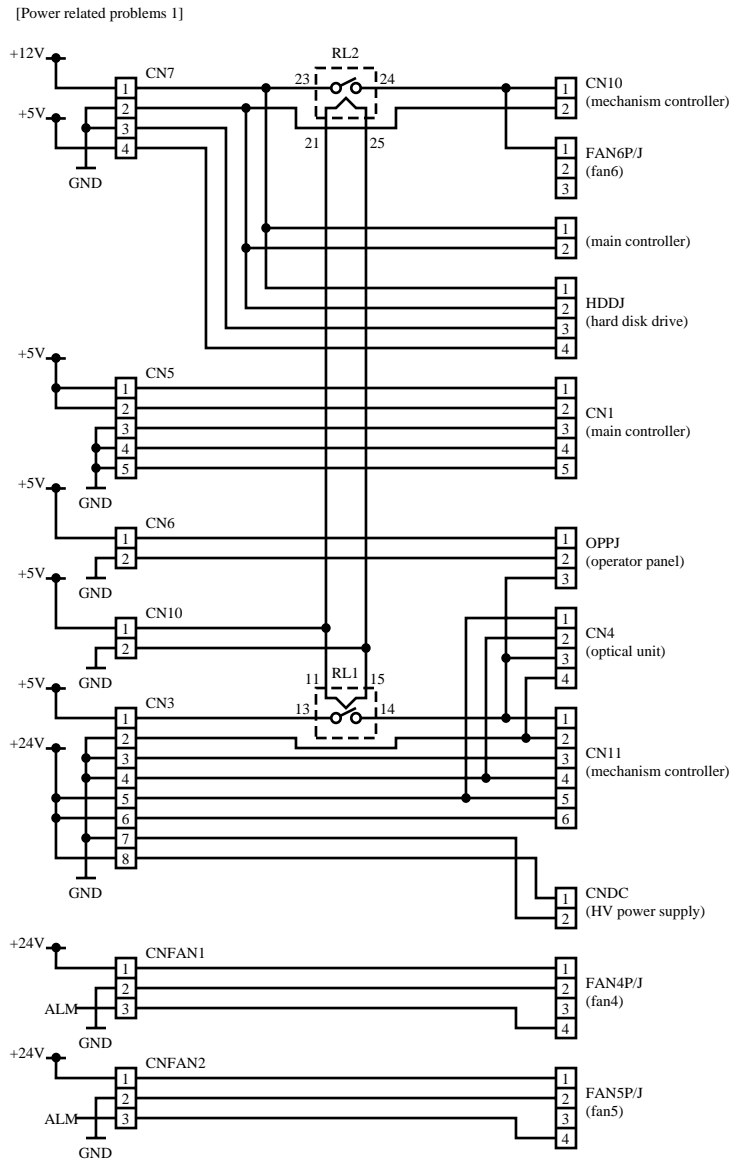

Figure 5-14. Power Control 1 Interconnections Diagram (2 of 2)

5-4.2. Control Powers ON But Cannot Power Printer Mechanism ON**Explanation**

The printer can not be turned on, but the back-light of the operator panel is lit up.

Troubleshooting Procedure

<010> Remove the rear cover, then check the relay RL1 on the rear frame of the printer. Is the relay RL1 oscillated like a buzzer? (It may oscillate on about 36Hz. When this relay is buzzed, the overcurrent on +5V circuits supplied through the relay RL1 may be occurred. When not buzzed, the overcurrent in the RL1 itself or on +24V circuits may be occurred.) <Y:020, N:300>

<020> [+5V, toner empty sensor] Pull out the CN1 connector on the mechanism controller PCB. Can the printer be turned on? <Y:022, N:030>

<022> Pull out the TEMPP connector near the developing unit. Can the printer be turned on? <Y:024, N:026>

<024> Replace the developing unit.

<025> Exit.

<026> Check damages or pinches of wires, cables, and connectors between following connectors:

CN1 on the mechanism controller PCB and TEMPP connector near the developing unit.

<027> Exit.

<030> [+5V, PS1-1/PLS1/PEMP1] Pull out the CN2 on the mechanism controller PCB. Can the printer be turned on? <Y:200, N:040>

<040> [+5V, PS1-2/PLS2/PEMP2] Pull out the CN3 on the mechanism controller PCB. Can the printer be turned on? <Y:220, N:050>

<050> [+5V, PS1-3/PLS3/PEMP3] Pull out the CN4 on the mechanism controller PCB. Can the printer be turned on? <Y:240, N:060>

<060> [+5V, PS2/PS3/PS4] Pull out the CN23 on the mechanism controller PCB. Can the printer be turned on? <Y:180, N:070>

<070> [+5V, PS5] Pull out the CN20 connector on the mechanism controller PCB. Can the printer be turned on? <Y:072, N:080>

<072> Pull out the PS5J connector at the duplex unit. Can the printer be turned on? <Y:074, N:076>

<074> Replace the sensor PS5.

<075> Exit.

<076> Check damages or pinches of wires, cables, and connectors between following connectors:

CN20 on the mechanism controller PCB and PS5J connector at the duplex unit.

<077> Exit.

<080> [+5V, PS6/PS7/stacker full sensor] Pull out the CN18 on the mechanism controller PCB.
Can the printer be turned on? <Y:160, N:090>

<090> [+5V, main motor/toner waste screw sensor] Pull out the CN21 on the mechanism controller PCB. Can the printer be turned on? <Y:150, N:100>

<100> [+5V, LCH] If the LCH installed, pull out the CN7 connector on the mechanism controller PCB. Can the printer be turned on? <Y:102, N:110>

<102> Check damages or pinches of wires, cables, and connectors between following connectors:
CN7 on the mechanism controller PCB and the interface connector for the LCH,
the interface connector for the LCH and PW board-A of the LCH.

<104> Exit.

<110> [+5V, optical unit] Pull out the CN4 connector on the optical unit. Can the printer be turned on? <Y:112, N:114>

<112> Replace the optical unit.

<113> Exit.

<114> Check damages or pinches of wires, cables, and connectors between following connectors:
CN11 on the mechanism controller PCB and relay RL1,
CN11 on the mechanism controller PCB and PS4 connector on the optical unit.

<116> Is the printer still unable to turn on? <Y:118, N:Exit>

<118> Replace the mechanism controller PCB.

<119> Exit.

<150> [+5V, main motor] Pull out the MMJ connector at the main motor. Can the printer be turned on? <Y:152, N:154>

<152> Replace the driving unit M sub asy.

<153> Exit.

<154> [+5V, toner waste screw sensor] Pull out the SCRSJ connector at the driving unit M. Can the printer be turned on? <Y:156, N:158>

<156> Replace the toner waste screw sensor.

<157> Exit.

<158> Check damages or pinches of wires, cables, and connectors between following connectors:
CN21 on the mechanism controller PCB and MMJ at the main motor,
CN21 on the mechanism controller PCB and SCRSJ on the toner waste screw sensor.

<159> Exit.

<160> [+5V, PS6] Pull out the PS6P connector on the reversing unit. Can the printer be turned on? <Y:162, N:164>

<162> Replace the sensor PS6.

<163> Exit.

<164> [+5V, PS7] Pull out the PS7P connector on the ejection unit. Can the printer be turned on? <Y:166, N:168>

<166> Replace the sensor PS7.

<167> Exit.

<168> [+5V, stack full sensor] Pull out the STFLP connector at the stacker full sensor on the ejection unit. Can the printer be turned on? <Y:170, N:172>

<170> Replace the stack full sensor.

<171> Exit.

<172> Check damages or pinches of wires, cables, and connectors between following connectors:

CN18 on the mechanism controller PCB and MMJ at the main motor,

CN18 on the mechanism controller PCB and SCRSJ on the toner waste screw sensor.

CN18 on the mechanism controller PCB and SCRSJ on the toner waste screw sensor.

<173> Exit.

<180> [+5V, PS2] Pull out the PS6P connector on the reversing unit. Can the printer be turned on? <Y:182, N:184>

<182> Replace the sensor PS6.

<183> Exit.

<184> [+5V, PS3] Pull out the PS7P connector on the ejection unit. Can the printer be turned on? <Y:186, N:188>

<186> Replace the sensor PS7.

<187> Exit.

<188> [+5V, PS4] Pull out the STFLP connector at the stacker full sensor on the ejection unit. Can the printer be turned on? <Y:190, N:192>

<190> Replace the stack full sensor.

<191> Exit.

<192> Check damages or pinches of wires, cables, and connectors between following connectors:

CN18 on the mechanism controller PCB and MMJ at the main motor,

CN18 on the mechanism controller PCB and SCRSJ on the toner waste screw sensor.

CN18 on the mechanism controller PCB and SCRSJ on the toner waste screw sensor.

<193> Exit.

<200> [+5V, PS1-1] Pull out the PSJ1 connector on the upper feed unit. Can the printer be turned on? <Y:202, N:204>

<202> Replace the sensor PS1-1.

<203> Exit.

<204> [+5V, PEMP1] Pull out the PEMPJ1 connector on the upper feed unit. Can the printer be turned on? <Y:206, N:208>

<206> Replace the paper empty sensor PEMP1.

<207> Exit.

<208> Remove the upper feed unit.

<210> [+5V, PLS1] Pull out the PLS1 connector on the upper feed unit. Can the printer be turned on? <Y:212, N:214>

<212> Replace the paper level sensor PLS1.

<213> Exit.

<214> Check damages or pinches of wires, cables, and connectors between following connectors:

CN2 on the mechanism controller PCB and PSJ1 on the upper feed unit,

CN2 on the mechanism controller PCB and PEMPJ1 on the upper feed unit,

CN2 on the mechanism controller PCB and PLS1 on the upper feed unit.

<215> Exit.

<220> [+5V, PS1-2] Pull out the PSJ2 connector on the middle feed unit. Can the printer be turned on? <Y:222, N:224>

<222> Replace the sensor PS1-2.

<223> Exit.

<224> [+5V, PEMP2] Pull out the PEMPJ2 connector on the middle feed unit. Can the printer be turned on? <Y:226, N:228>

<226> Replace the paper empty sensor PEMP2.

<227> Exit.

<228> Remove the middle feed unit.

<230> [+5V, PLS2] Pull out the PLSJ2 connector on the middle feed unit. Can the printer be turned on? <Y:232, N:234>

<232> Replace the paper level sensor PLS2.

<233> Exit.

<234> Check damages or pinches of wires, cables, and connectors between following connectors:

CN3 on the mechanism controller PCB and PSJ2 on the middle feed unit,

CN3 on the mechanism controller PCB and PEMPJ2 on the middle feed unit,

CN3 on the mechanism controller PCB and PLS2 on the middle feed unit.

<235> Exit.

<240> [+5V, PS1-3] Pull out the PSJ3 connector on the lower feed unit. Can the printer be turned on? <Y:242, N:244>

<242> Replace the sensor PS1-3.

<243> Exit.

<244> [+5V, PEMP3] Pull out the PEMPJ3 connector on the lower feed unit. Can the printer be turned on? <Y:246, N:248>

<246> Replace the paper empty sensor PEMP3.

<247> Exit.

<248> Remove the lower feed unit.

<250> [+5V, PLS3] Pull out the PLSJ3 connector on the lower feed unit. Can the printer be turned on? <Y:252, N:254>

<252> Replace the paper level sensor PLS3.

<253> Exit.

<254> Check damages or pinches of wires, cables, and connectors between following connectors:

CN4 on the mechanism controller PCB and PSJ3 on the lower feed unit,

CN4 on the mechanism controller PCB and PEMPJ3 on the lower feed unit,

CN4 on the mechanism controller PCB and PLS3 on the lower feed unit.

<255> Exit.

<300> [+5V, relay RL1] Check the voltage at the RL1, between “14” labeled terminal and GND. Is the voltage $+4.82V \pm 0.02V$ <Y:330, N:310>

<310> Check the voltage at the RL1, between “11” labeled terminal and “15” labeled terminal. Is the voltage $+4.82V \pm 0.02V$ <Y:320, N:312>

<312> Check damages or pinches of wires, cables, and connectors between following connectors:

CN10 on the power supply PCB and relay RL1.

<314> Is the printer still unable to turn on? <Y:600, N:Exit>

<320> Check the voltage at the RL1, between “13” labeled terminal and GND. Is the voltage $+4.82V \pm 0.02V$ <Y:322, N:600>

<322> Replace the relay RL1.

<324> Is the printer still unable to turn on? <Y:330, N:Exit>

<330> [+24V, pick motor1] Pull out the CN2 connector on the mechanism controller PCB. Can the printer be turned on? <Y:332, N:340>

<332> Pull out the PMP1 connector on the upper feed unit. Can the printer be turned on? <Y:334, N:336>

<334> Replace the pick motor1. If you want to save your time to repair, replace the feed unit.

<335> Exit.

<336> Check damages or pinches of wires, cables, and connectors between following connectors:

CN2 on the mechanism controller PCB and PMP1 connector on the upper feed unit.

<337> Exit.

<340> [+24V, pick motor2] Pull out the CN3 connector on the mechanism controller PCB. Can the printer be turned on? <Y:342, N:350>

<342> Pull out the PMP2 connector on the middle feed unit. Can the printer be turned on? <Y:344, N:346>

<344> Replace the pick motor2. If you want to save your time to repair, replace the feed unit.

<345> Exit.

<346> Check damages or pinches of wires, cables, and connectors between following connectors:
CN3 on the mechanism controller PCB and PMP2 connector on the middle feed unit.

<347> Exit.

<350> [+24V, pick motor3] Pull out the CN4 connector on the mechanism controller PCB. Can the printer be turned on? <Y:352, N:350>

<352> Pull out the PMP3 connector on the lower feed unit. Can the printer be turned on? <Y:354, N:356>

<354> Replace the pick motor3. If you want to save your time to repair, replace the feed unit.

<355> Exit.

<356> Check damages or pinches of wires, cables, and connectors between following connectors:
CN4 on the mechanism controller PCB and PMP3 connector on the lower feed unit.

<357> Exit.

<360> [+24V, toner motor/developer shutter motor] Pull out the CN1 connector on the mechanism controller PCB. Can the printer be turned on? <Y:440, N:370>

<370> [+24V, main motor/regist roller clutch] Pull out the CN21 connector on the mechanism controller PCB. Can the printer be turned on? <Y:460, N:380>

<380> [+24V, duplex motor] Pull out the CN20 connector on the mechanism controller PCB. Can the printer be turned on? <Y:382, N:390>

<382> Pull out the DPMP1 connector on the duplex unit. Can the printer be turned on? <Y:384, N:386>

<384> Replace the duplex motor. If you want to save your time to repair, replace the duplex unit.

<385> Exit.

<386> Check damages or pinches of wires, cables, and connectors between following connectors:
CN20 on the mechanism controller PCB and DPMP1 connector on the duplex unit.

<387> Exit.

<390> [+24V, reversing motor/solenoids] Pull out the CN18 connector on the mechanism controller PCB. Can the printer be turned on? <Y:480, N:400>

<400> [+24V, feed motor/lift motors] Pull out the CN6 connector on the mechanism controller PCB. Can the printer be turned on? <Y:510, N:410>

<410> [+24V, fans] Pull out the CN22 connector on the mechanism controller PCB. Can the

printer be turned on? <Y:540, N:420>

<420> [+24V, LED unit] Pull out the CN23 connector on the mechanism controller PCB. Can the printer be turned on? <Y:422, N:430>

<422> Pull out the CLEDP connector at the LED unit. Can the printer be turned on? <Y:424, N:426>

<424> Replace the LED unit.

<425> Exit.

<426> Check damages or pinches of wires, cables, and connectors between following connectors:
CN23 on the mechanism controller PCB and CLEDP connector at the LED unit.

<427> Exit.

<430> [+24V, optical unit (LD)] Pull out the CN15 connector on the mechanism controller PCB. Can the printer be turned on? <Y:432, N:600>

<432> Pull out the CN2 connector on the optical unit. Can the printer be turned on? <Y:434, N:436>

<434> Replace the optical unit.

<435> Exit.

<436> Check damages or pinches of wires, cables, and connectors between following connectors:
CN15 on the mechanism controller PCB and CN2 connector on the optical unit.

<437> Exit.

<440> [+24V, developer shutter motor] Pull out the MGSJH connector of the developer shutter motor. Can the printer be turned on? <Y:442, N:444>

<442> Replace the developer shutter motor.

<443> Exit.

<444> [+24V, toner motor] Pull out the TNMJ connector of the toner motor. Can the printer be turned on? <Y:446, N:448>

<446> Replace the toner motor.

<447> Exit.

<448> Check damages or pinches of wires, cables, and connectors between following connectors:
CN1 on the mechanism controller PCB and MGSJH connector of the developer shutter motor,
CN1 on the mechanism controller PCB and TNMJ connector of the toner motor.

<449> Exit.

<460> [+24V, main motor] Pull out the MMJ connector of the main motor. Can the printer be turned on? <Y:462, N:464>

<462> Replace the driving unit M sub asy.

<463> Exit.

<464> [+24V, regist roller clutch] Pull out the RCLP connector of the regist roller clutch. Can the printer be turned on? <Y:466, N:468>

<466> Replace the regist roller clutch.

<467> Exit.

<468> Check damages or pinches of wires, cables, and connectors between following connectors:
CN21 on the mechanism controller PCB and MMJ connector of the main motor,

CN21 on the mechanism controller PCB and RCLP connector of the regist roller clutch.

<469> Exit.

<480> [+24V, reversing motor] Pull out the SBMP connector of the reversing motor. Can the printer be turned on? <Y:482, N:484>

<482> Replace the reversing motor. If you want to save your time to repair, replace the reversing unit.

<483> Exit.

<484> [+24V, stacker select solenoid] Pull out the STSLP connector of the stacker select solenoid. Can the printer be turned on? <Y:486, N:488>

<486> Replace the stacker select solenoid. If you want to save your time to repair, replace the reversing unit.

<487> Exit.

<488> [+24V, purge solenoid] Pull out the STCHP connector of the purge solenoid. Can the printer be turned on? <Y:490, N:492>

<490> Replace the purge solenoid. If you want to save your time to repair, replace the reversing unit.

<491> Exit.

<492> Check damages or pinches of wires, cables, and connectors between following connectors:

CN18 on the mechanism controller PCB and SBMP connector of the reversing motor,

CN18 on the mechanism controller PCB and STSLP connector of the stacker select solenoid,

CN18 on the mechanism controller PCB and STCHP connector of the purge solenoid.

<493> Exit.

<510> [+24V, feed motor] Pull out the FMP connector of the feed motor. Can the printer be turned on? <Y:512, N:514>

<512> Replace the feed motor.

<513> Exit.

<514> [+24V, upper lift motor] Pull out the CLM1J connector of the upper lift motor. Can the printer be turned on? <Y:516, N:518>

<516> Replace the upper lift motor.

<517> Exit.

<518> [+24V, middle lift motor] Pull out the CLM2J connector of the middle lift motor. Can the printer be turned on? <Y:520, N:522>

<520> Replace the middle lift motor.

<521> Exit.

<522> [+24V, lower lift motor] Pull out the CLM3J connector of the lower lift motor. Can the printer be turned on? <Y:524, N:526>

<524> Replace the lower lift motor.

<525> Exit.

<526> Check damages or pinches of wires, cables, and connectors between following connectors:

CN6 on the mechanism controller PCB and FMP connector of the feed motor,

CN6 on the mechanism controller PCB and CLM1J connector of the upper lift motor,

CN6 on the mechanism controller PCB and CLM2J connector of the middle lift motor,

CN6 on the mechanism controller PCB and CLM3J connector of the lower lift motor.

<527> Exit.

<540> [+24V, fan1] Pull out the FAN1P connector near at the optical unit. Can the printer be turned on? <Y:542, N:544>

<542> Replace the optical unit. (The fan1 is in the optical unit, and it can not be replaced individually.)

<543> Exit.

<544> [+24V, fan2] Pull out the FAN2P connector of the fan2 (internal cooling fan at upper left of the rear side of the printer). Can the printer be turned on? <Y:546, N:548>

<546> Replace the fan2.

<547> Exit.

<550> Replace the fan3.

<551> Exit.

<552> [+24V, fan7] Pull out the FAN7P connector of the fan7 (internal cooling fan at lower left of the rear side of the printer). Can the printer be turned on? <Y:554, N:556>

<554> Replace the fan7.

<555> Exit.

<556> Check damages or pinches of wires, cables, and connectors between following connectors:

CN22 on the mechanism controller PCB and FAN1P connector of the fan1,
CN22 on the mechanism controller PCB and FAN2P connector of the fan2,
CN22 on the mechanism controller PCB and FAN7P connector of the fan7.

<557> Exit.

<600> Replace the power supply PCB.

<602> Exit.

Reference Diagrams

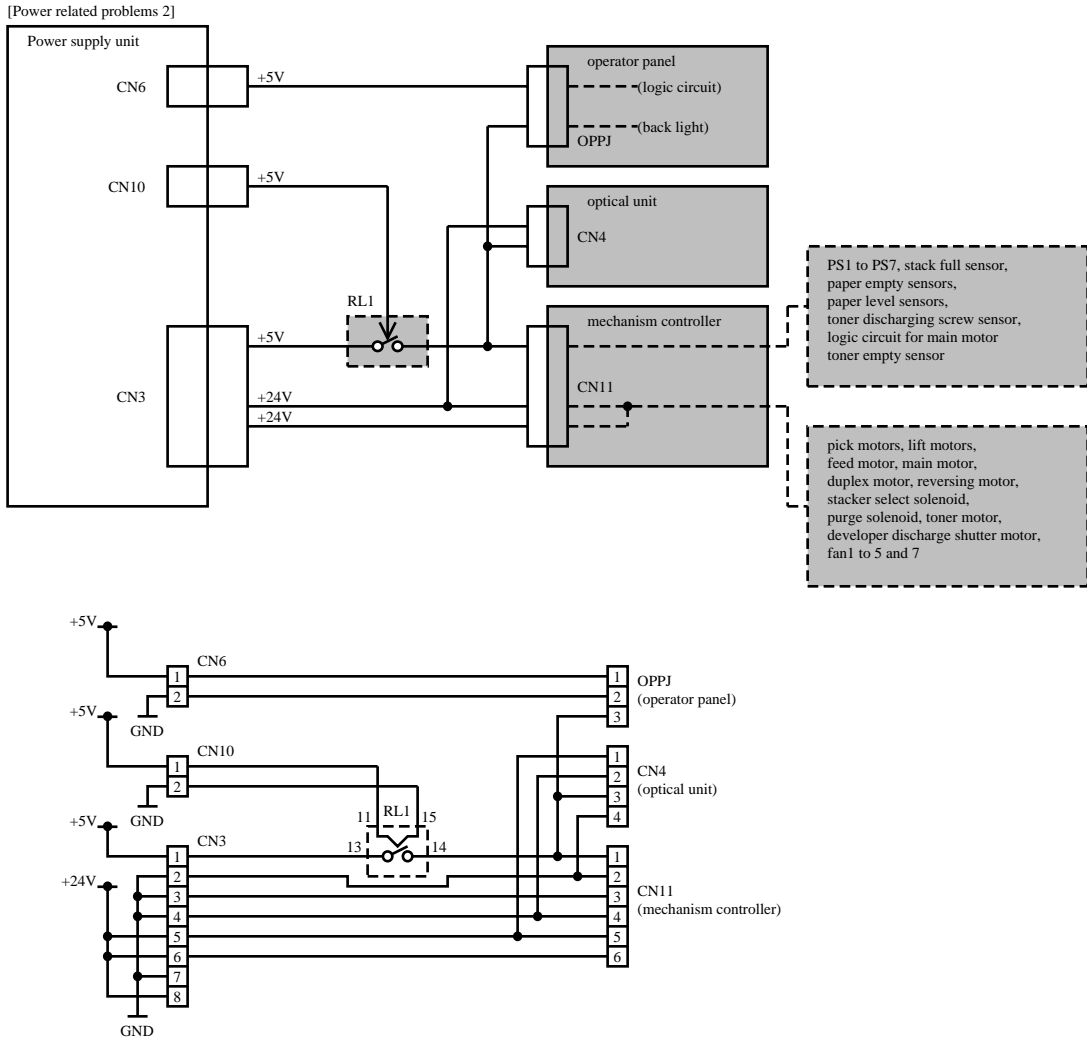

Figure 5-15. Power Control 2 Interconnections Diagram

5-4.3. Cannot Power Off Printer With Stand-by Switch

Explanation

The printer can not be turned off by the stand-by switch.

Troubleshooting Procedure

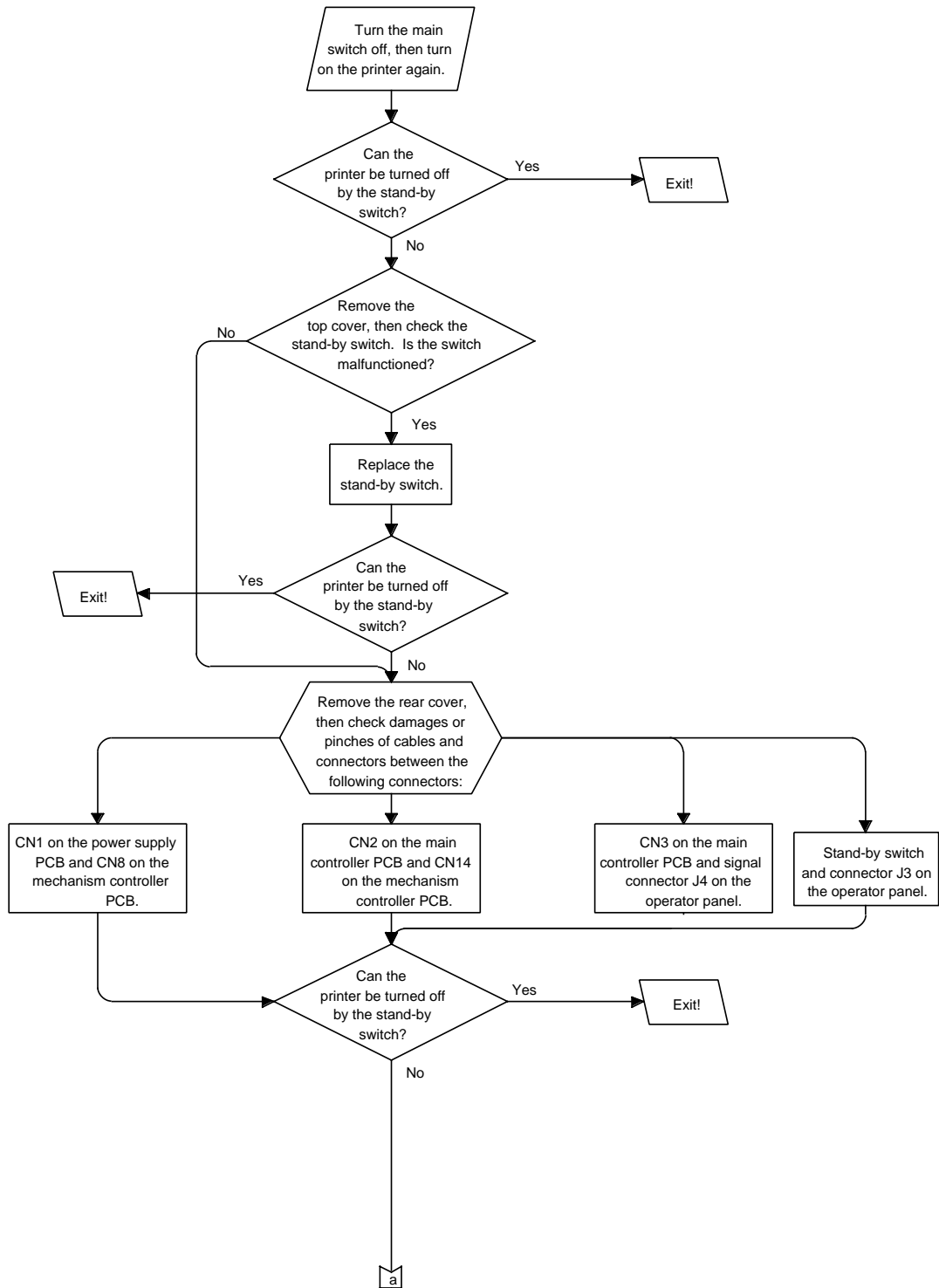

Figure 5-16. Cannot Power Off Printer With Stand-by Switch Flow Chart (1 of 2)

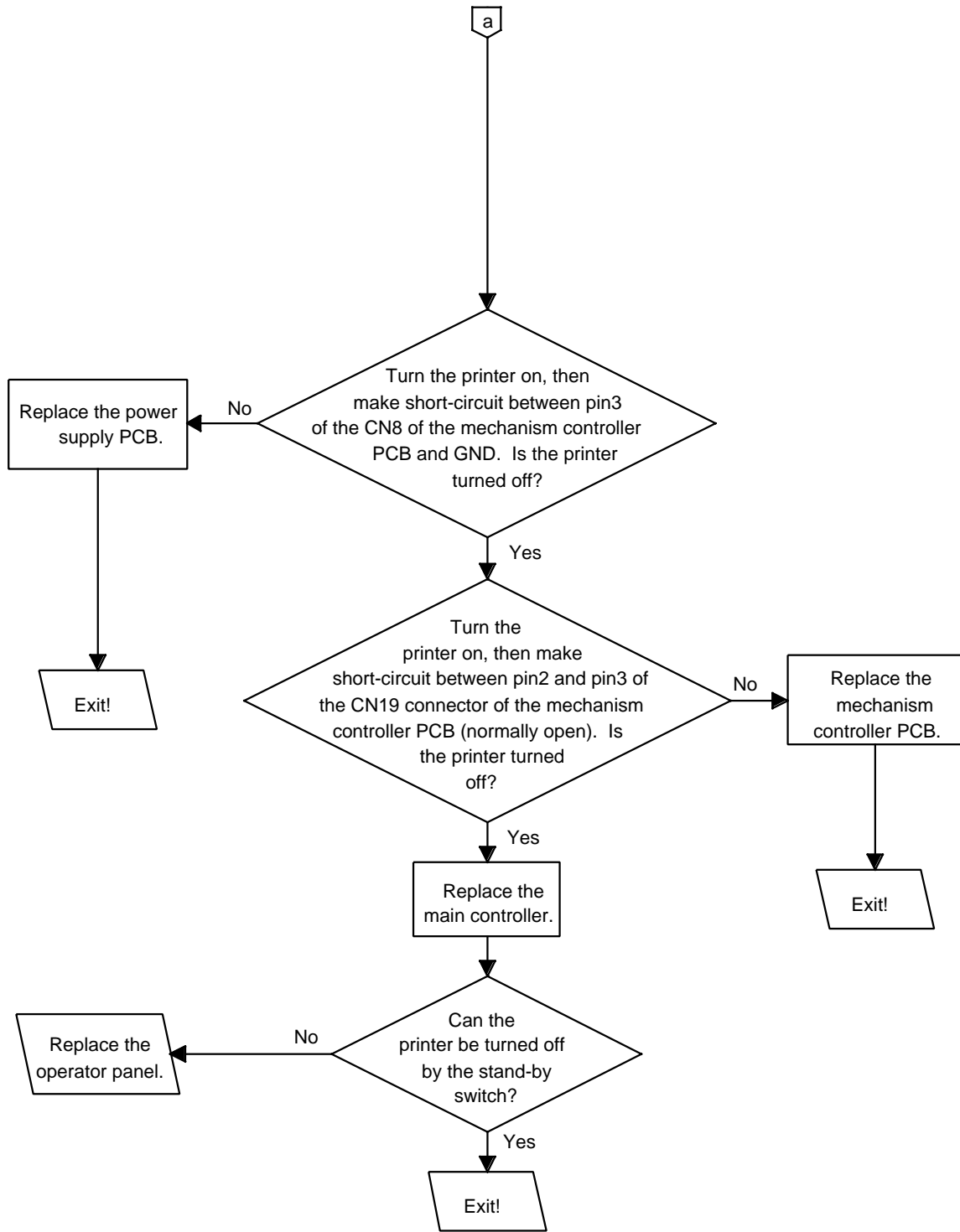

Figure 5-16. Cannot Power Off Printer With Stand-by Switch Flow Chart (2 of 2)

Reference Diagrams

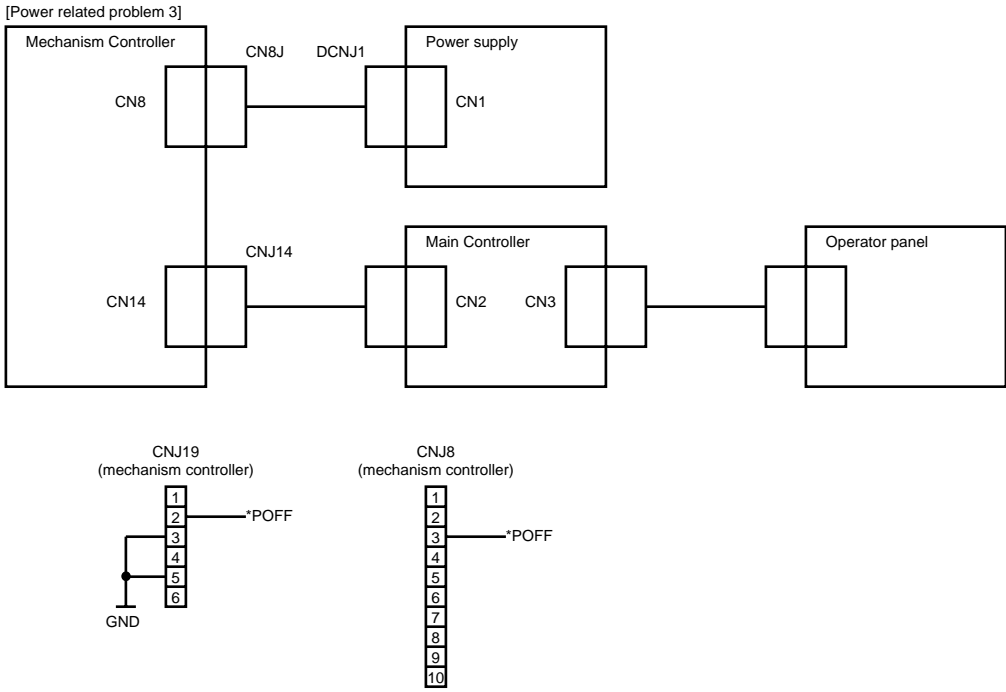

Figure 5-17. Power Control 3 Interconnections Diagram

5-5. Miscellaneous Problems

5-5.1. Operator Panel Symptoms

Explanation

Printer does not respond when any buttons on the operator panel is pressed, or
Valid but obviously wrong error message is displayed on the operator panel.

Reference Diagrams

None

Troubleshooting Procedure

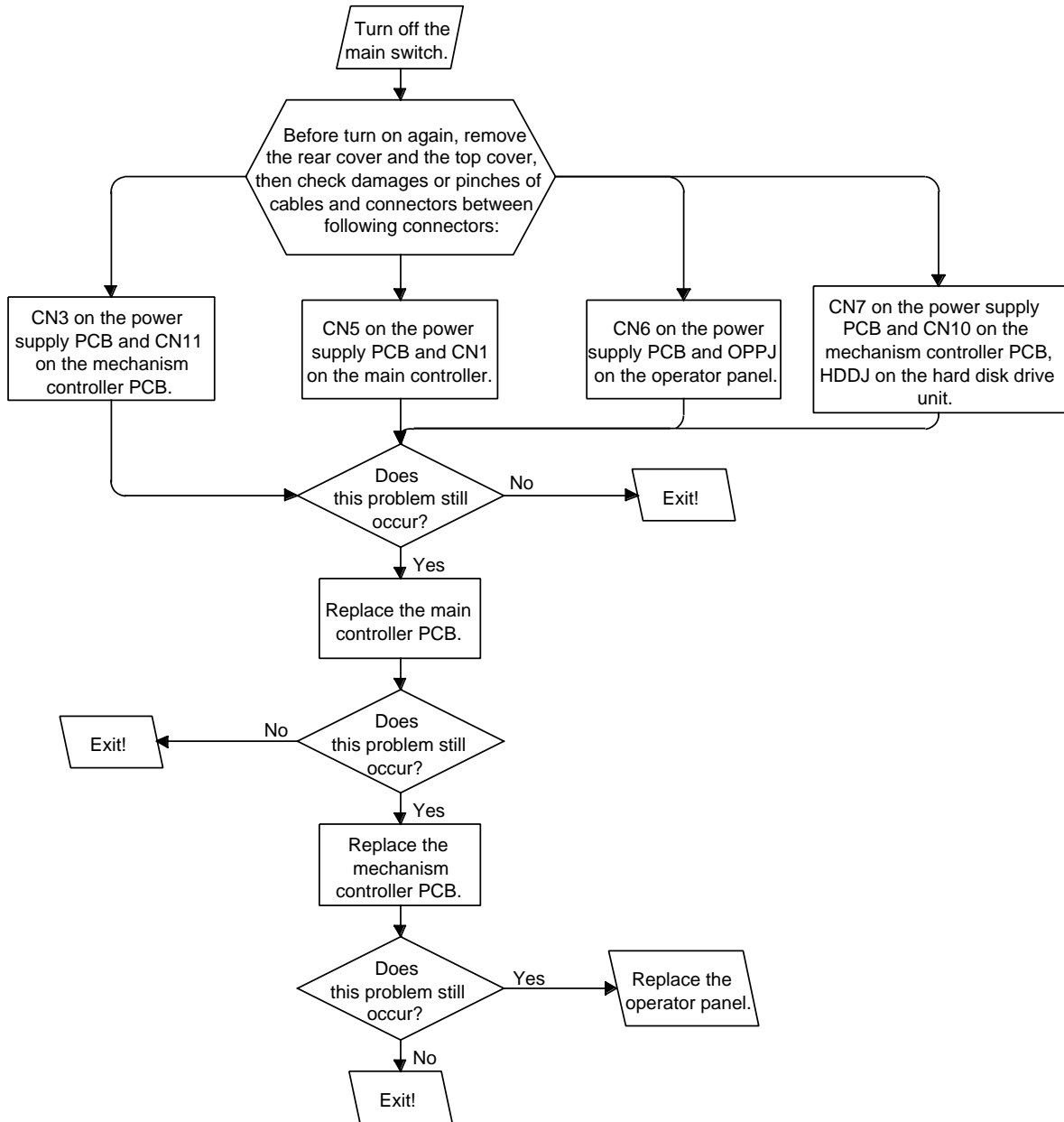

Figure 5-18. Operator Panel Control Related Problems Flow Chart

5-5.2. Cover Open / Interlock

Explanation

The interlock of following cover, door, or unit was detected:

- Drum unit
- Front door
- Upper right cover
- Fuser unit
- Lower right cover
- Ejection unit cover

Troubleshooting Procedure

<010> Check whether the cover or door is closed completely, whether the unit is set correctly and completely. Is the door or cover closed completely? Or is the unit set correctly? <Y:012, N:020>

<012> Close the door or cover completely, set the unit correctly.

<014> Does this alarm still occur? <Y:020, N:Exit>

<020> Remove the rear cover, then check damages or pinches of wires, cables, connector, and the switch itself.

In case of drum unit: Check between CN21 on the mechanism controller PCB and drum set switch (micro-switch) on the driving unit M.

In case of the front door, upper right cover, lower right cover, or the ejection unit cover: Check between CN2 on the mechanism controller PCB and each switches (micro-switch).

In case of the fuser, check between CN21 on the mechanism controller PCB and CNTJ connector on the driving unit M.

<022> Does this alarm still occur? <Y:030, N:Exit>

<030> Check the respective switch. Is the switch malfunctioned? <Y:032, N:040>

<032> Replace the respective switch.

In case of drum unit: Replace the switch on the driving unit M.

In case of the front door: Replace the switch on the main frame.

In case of the upper right cover: Replace the switch on the main frame.

In case of the lower right cover: Replace the switch on the main frame.

In case of the ejection unit cover: Replace the switch on the ejection unit.

In case of the fuser: Replace the fuser unit.

<034> Does this alarm still occur? <Y:040, N:Exit>

<040> Replace the mechanism controller PCB.

Troubleshooting Procedure

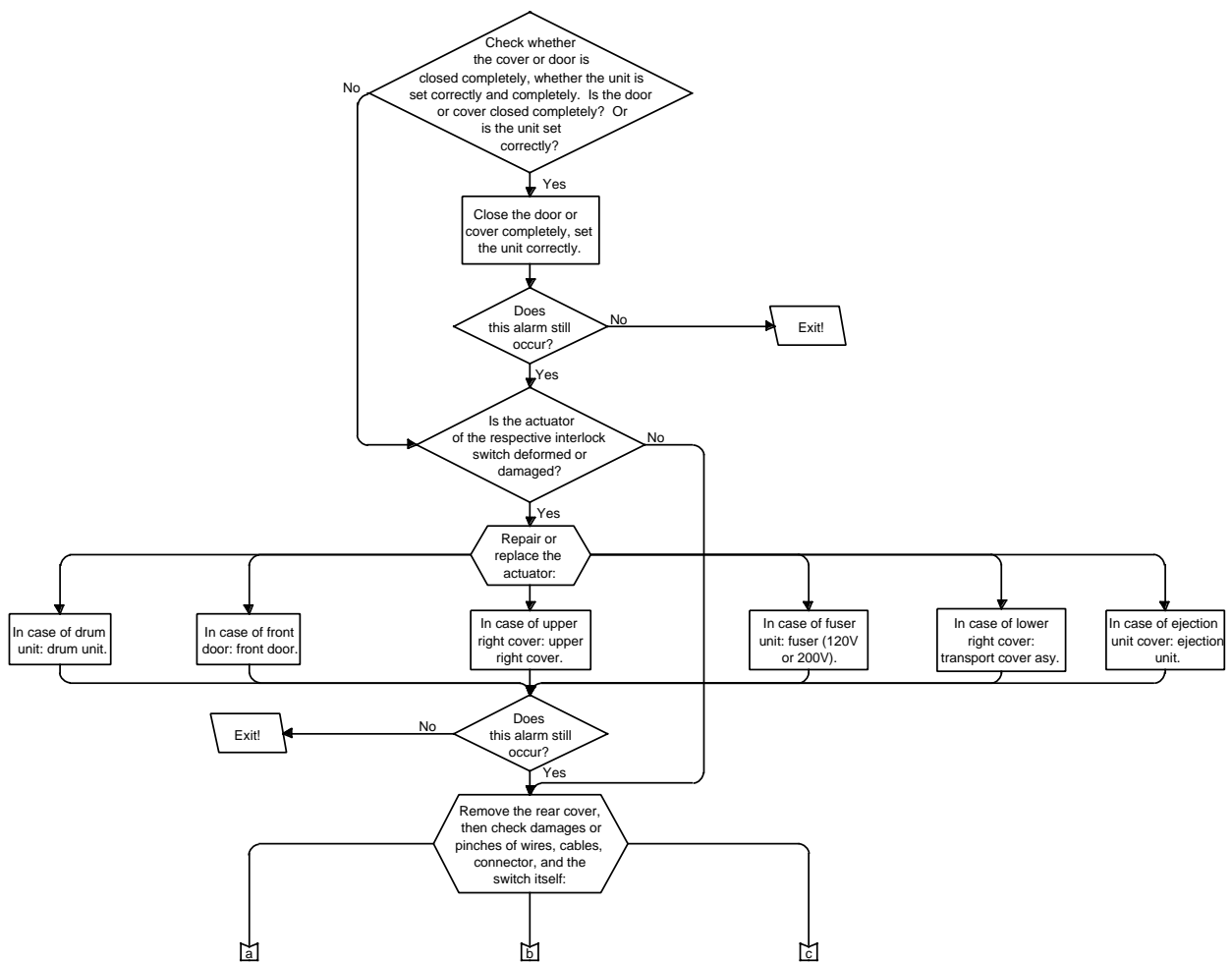

Figure 5-19. Cover Open / Interlock Flow Chart (1 of 2)

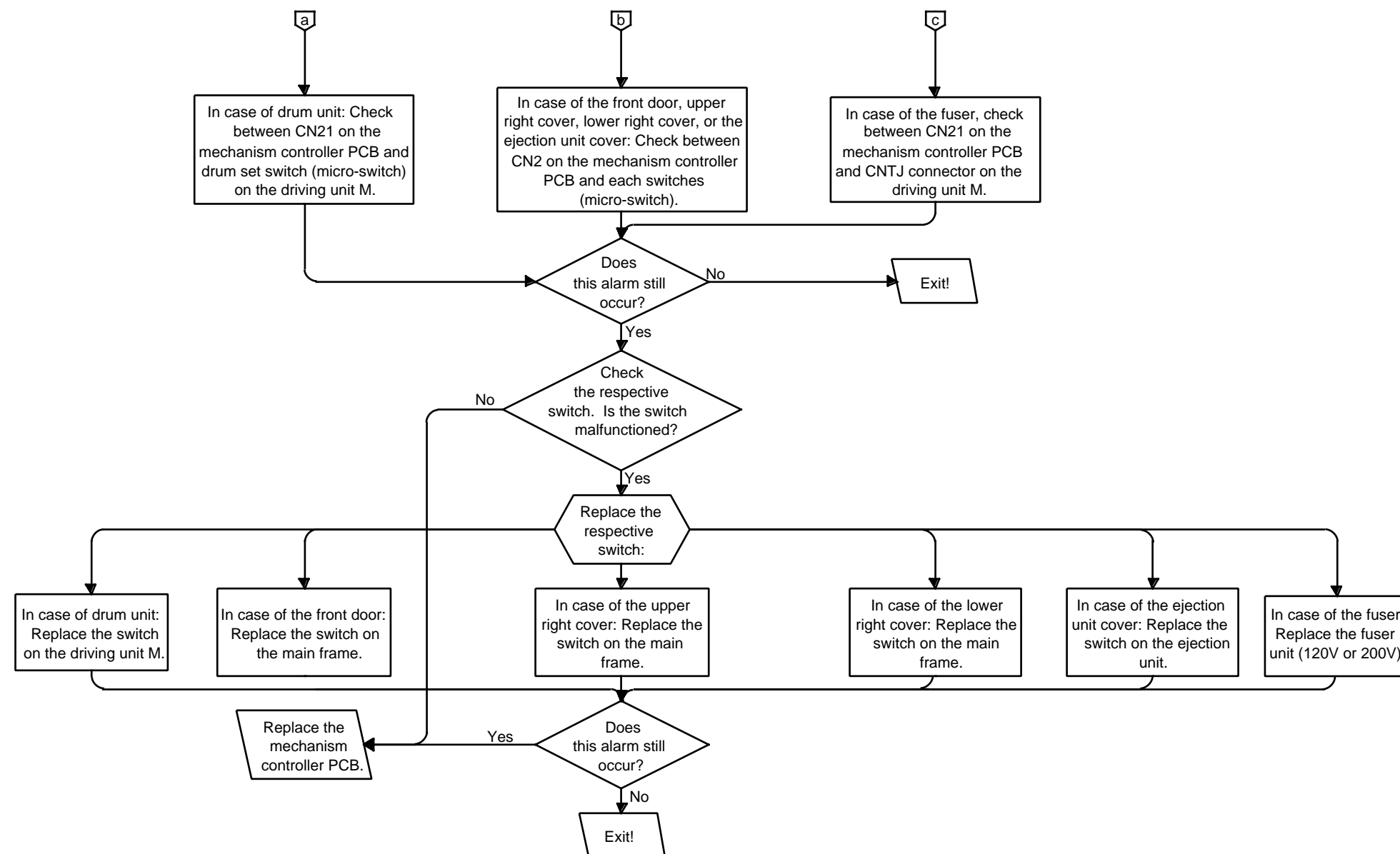

Figure 5-109.Cover Open / Interlock Flow Chart (2 of 2)

Reference Diagrams

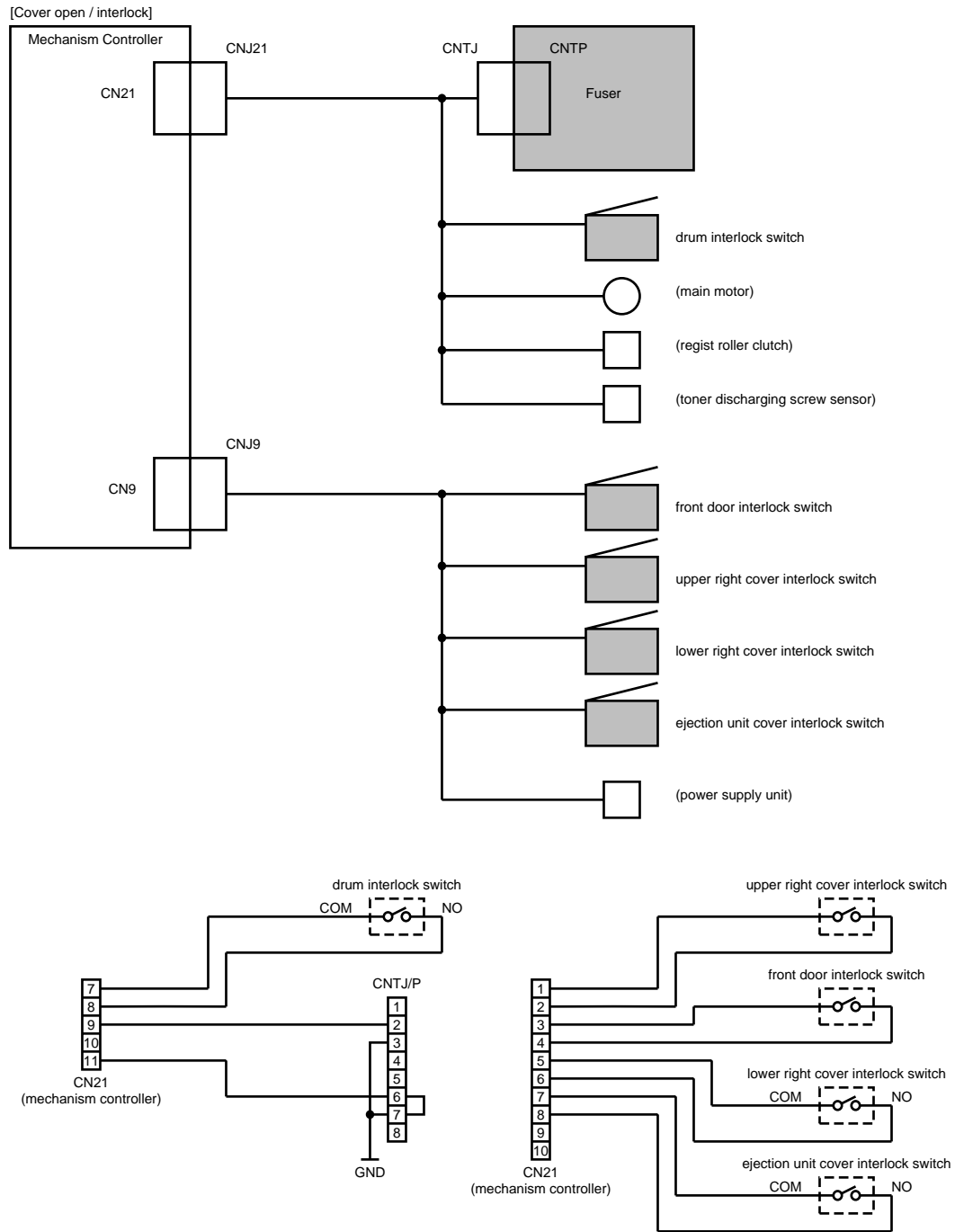

Figure 5-0. Interlock Microswitches Interconnections Diagram

5-5.3. Paper Tray Not Ready**Explanation**

A paper supply tray is open.

Troubleshooting Procedure

<010> Is the tray closed completely until it is locked? <Y:020, N:012>

<012> Close the tray completely.

<014> Does this alarm still occur? <Y:020, N:Exit>

<020> Remove the rear cover, then check damages or pinches of wires, cables, and connectors between CN5 on the mechanism controller PCB and each tray detection switch (micro-switch).

<022> Does this alarm still occur? <Y:030, N:Exit>

<030> Check the tray detection switch (see 4-138). Is the switch malfunctioned or its actuator bent? <Y:032, N:040>

<032> Replace the tray detection switch (CA02626-E142, see 4-138, fig.15-4).

<034> Does this alarm still occur? <Y:040, N:Exit>

<040> Pull out the tray and push the actuator of the tray detection switch by hand. Is the tray lift motor rotating? <Y:050, N:042>

<042> Check the damages or pinches of wire, cable, and connectors between CN6 on the mechanism controller PCB and the lift motor.

<044> Does this alarm still occur? <Y:046, N:Exit>

<046> Replace respective tray lift motor.

<048> Does this alarm still occur? <Y:050, N:Exit>

<050> Replace the mechanism controller PCB.

Reference Diagrams

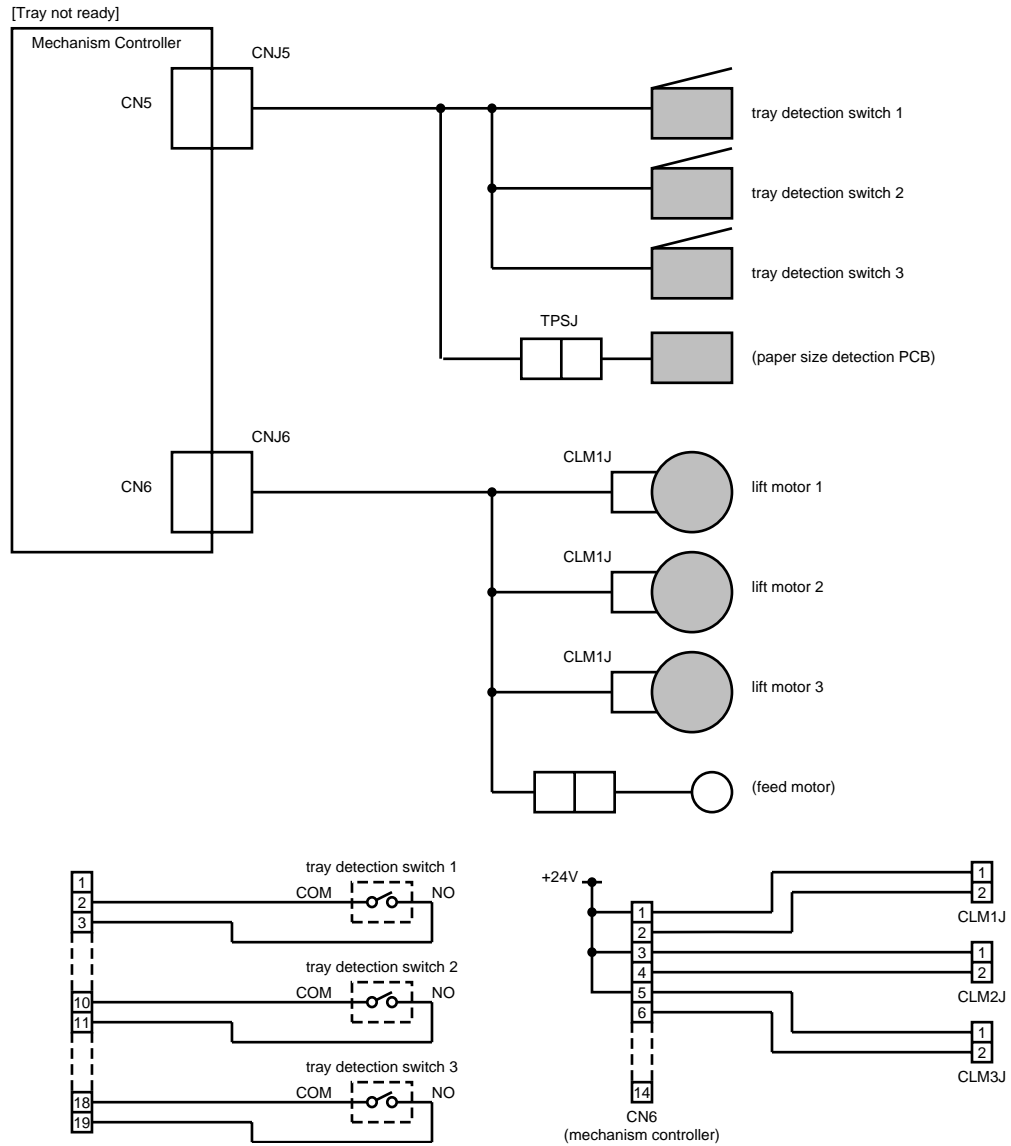

Figure 5-1. Paper Supply Tray Interconnections Diagram

5-5.4. Out of Paper

Explanation

Paper empty was detected, or

After a tray was set, the lift motor went up the paper within specific time and then the paper level was detected. The absence of paper was detected at that time.

Troubleshooting Procedures

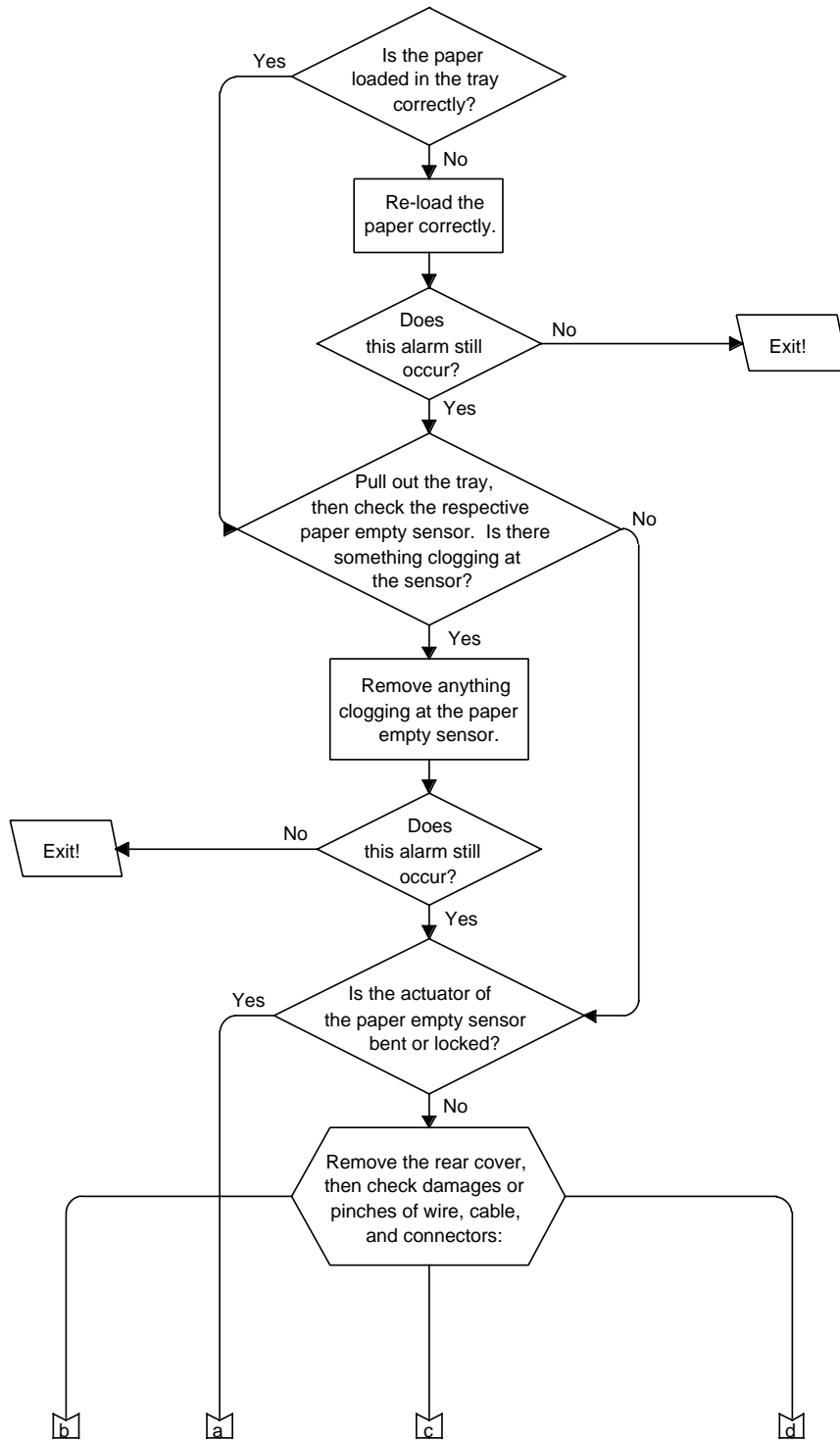

Figure 5-2. Out of Paper Flow Chart (1 of 2)

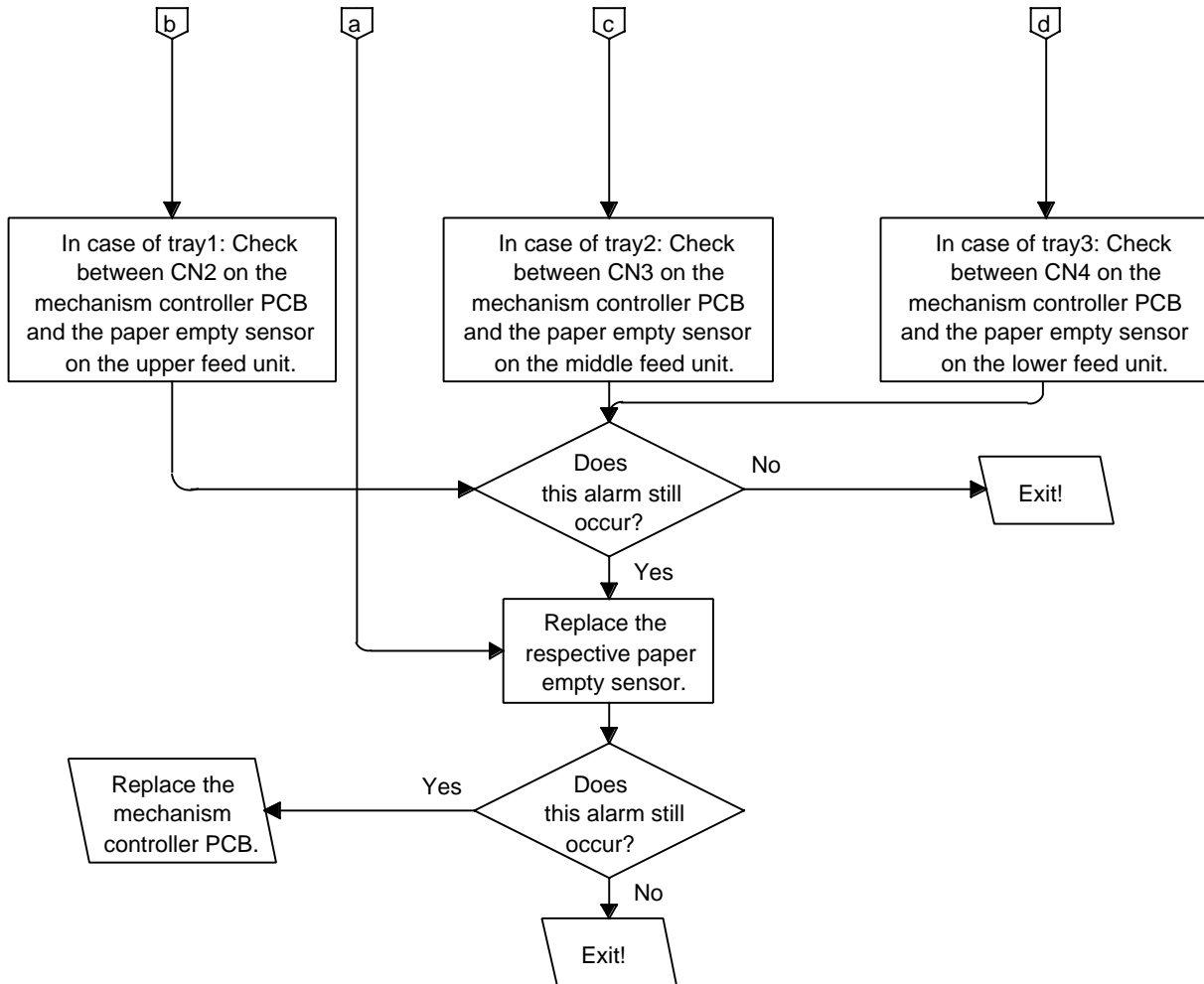

Figure 5-2. Out of Paper Flow Chart (2 of 2)

Reference Diagrams

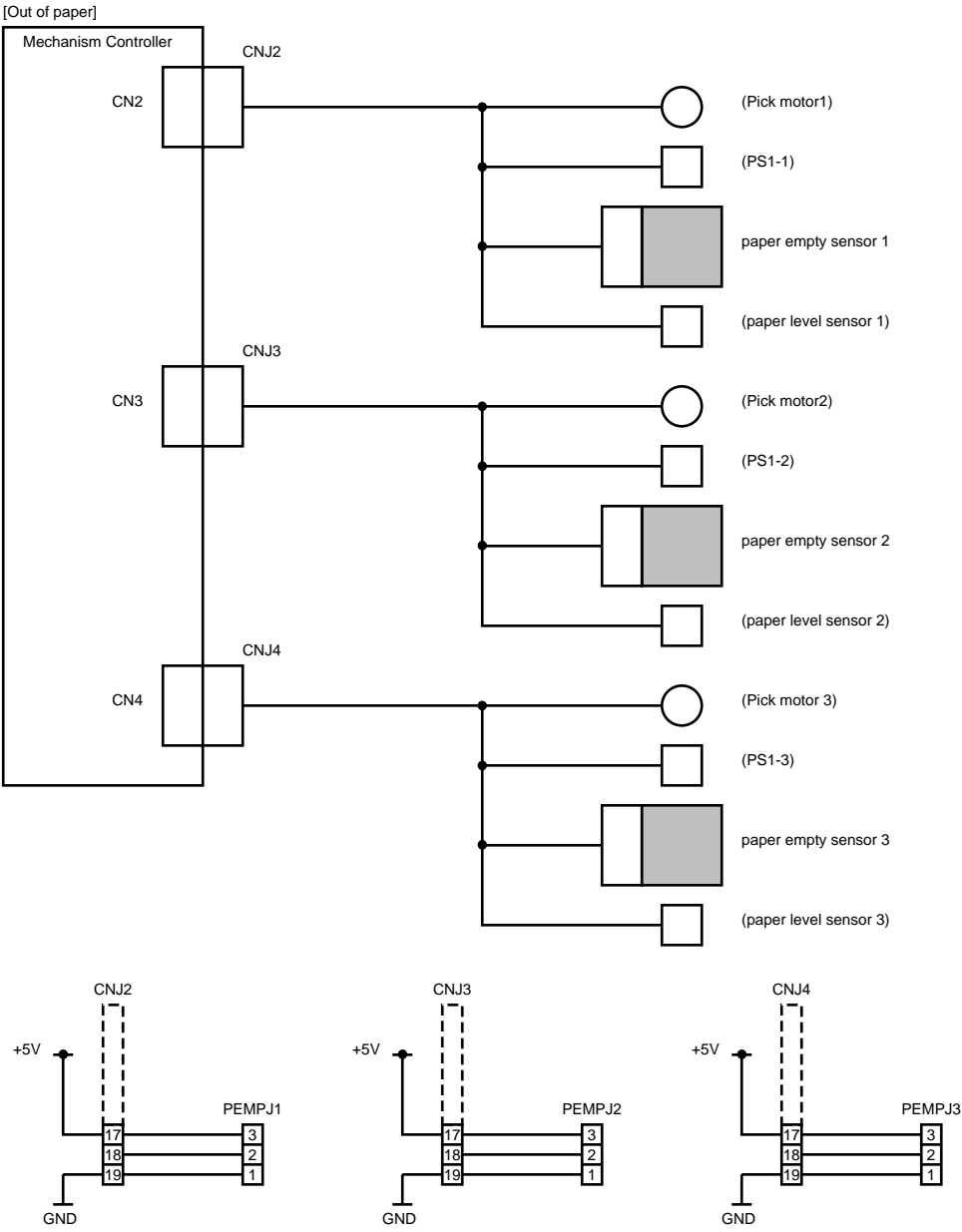

Figure 5-3. Out of Paper Interconnections Diagram

5-5.5. Stacker Full Cannot Be Cleared

Explanation

The stacker full can not be cleared.

Troubleshooting Procedure

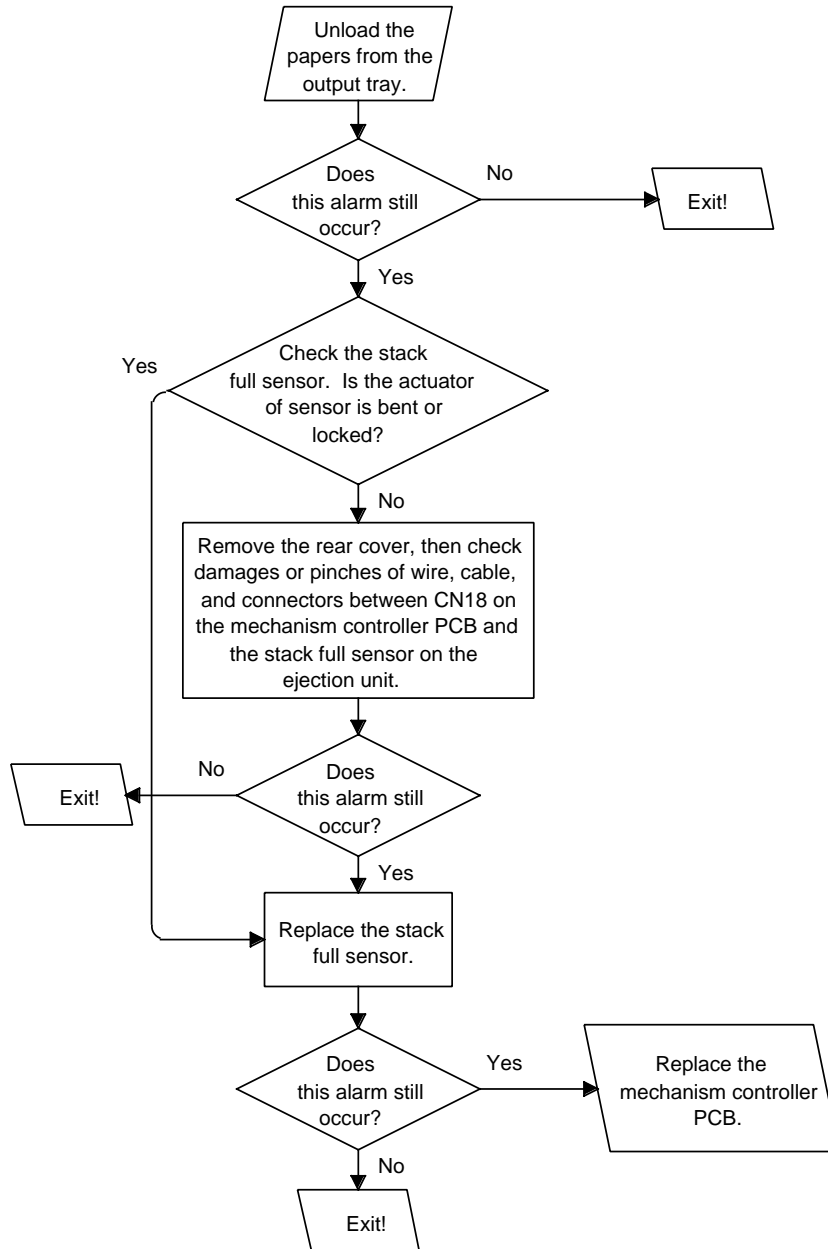

Figure 5-4. Stacker Full Cannot Be Cleared Flow Chart

Reference Diagrams

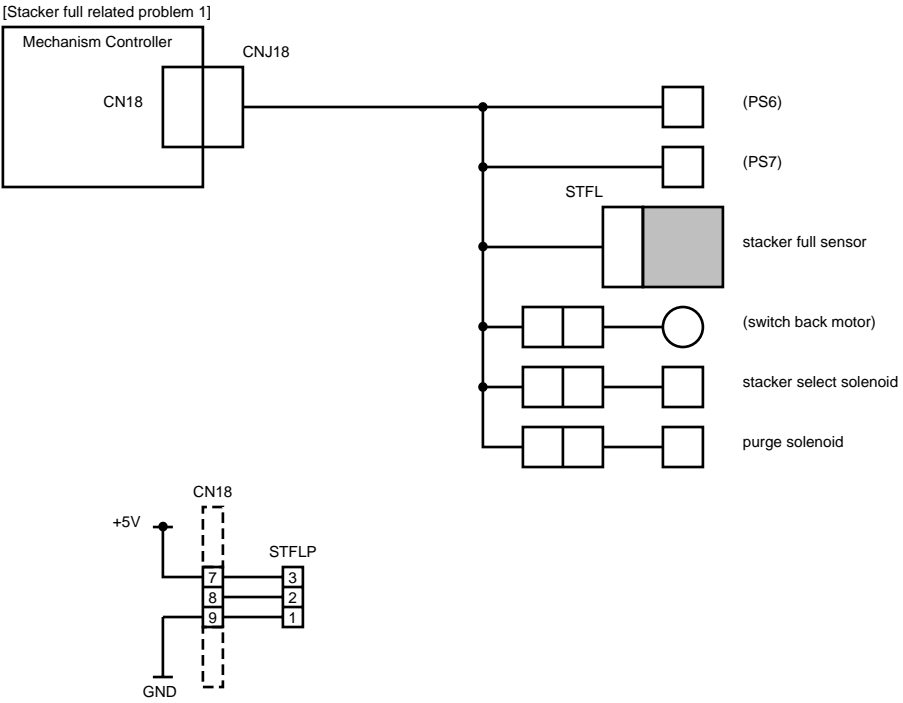

Figure 5-5. Stacker Full Cannot Be Cleared Interconnections Diagram

5-5.6. Stacker Full Cannot Be Detected

Explanation

The stacker full can not be detected.

Troubleshooting Procedure

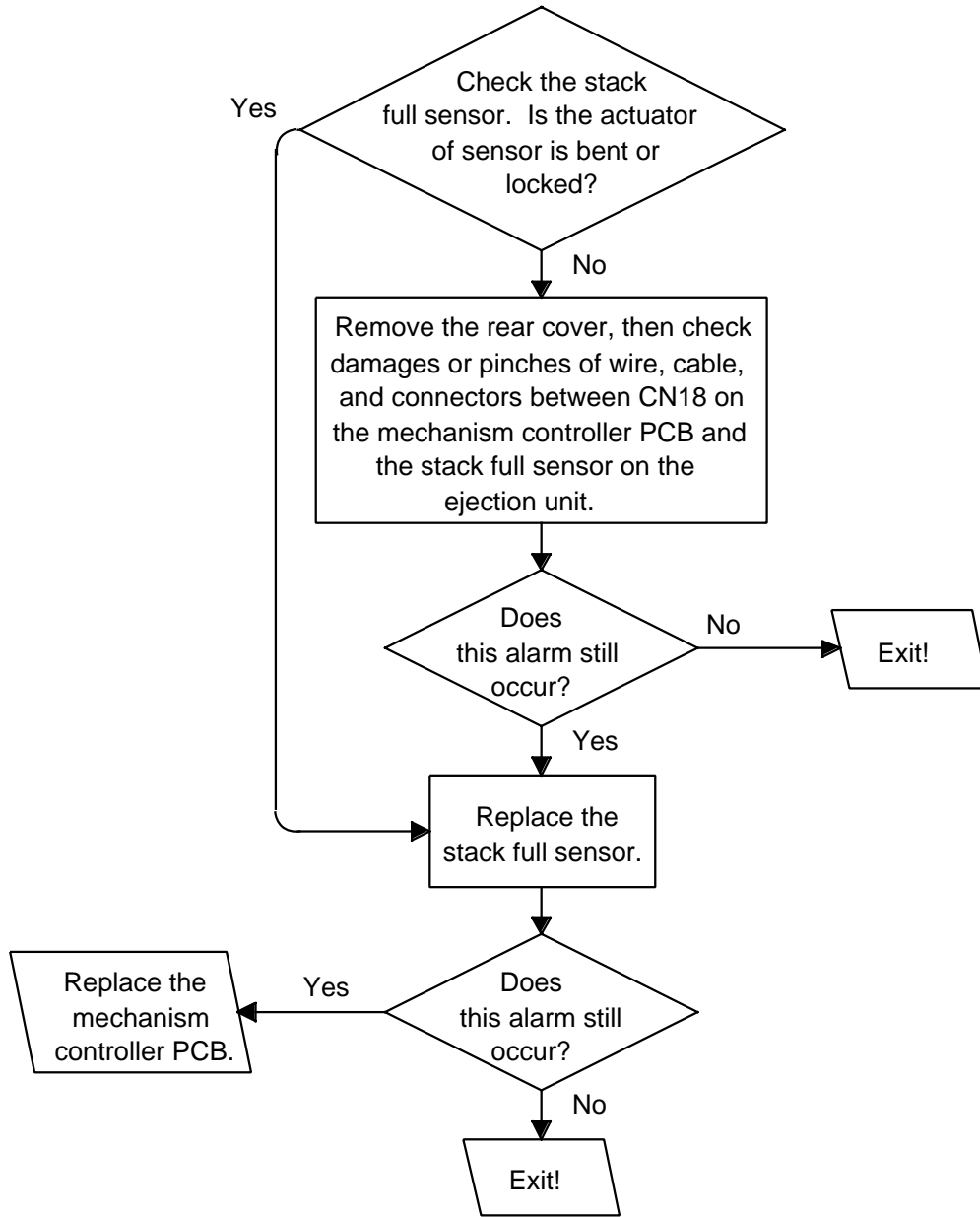

Figure 5-6. Stacker Full Cannot Be Detected Flow Chart

Reference Diagrams

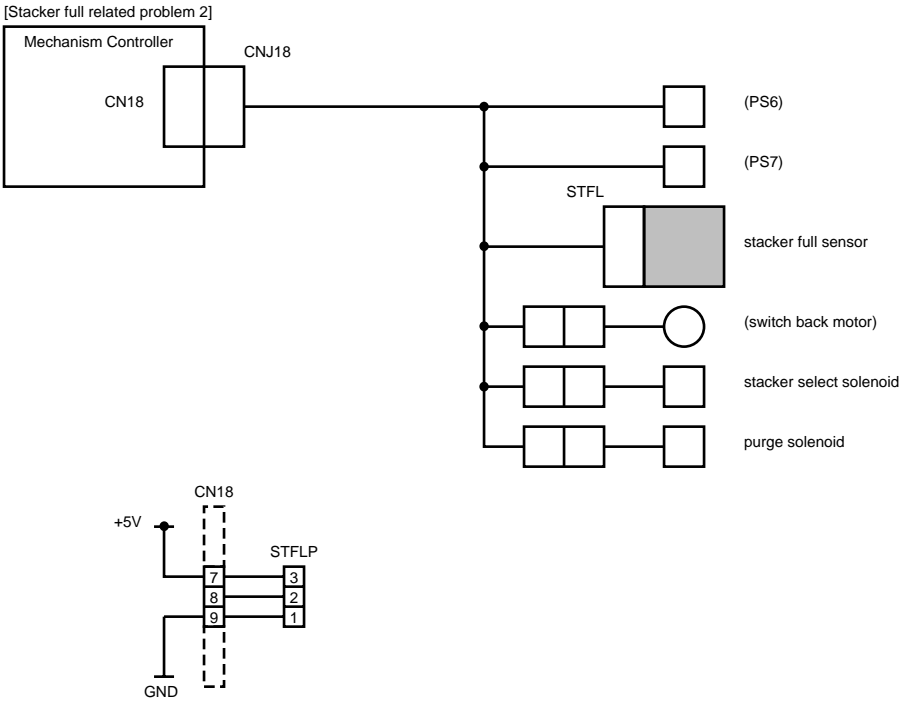

Figure 5-7. Stacker Full Cannot Be Detected Interconnections Diagram

5-5.7. Developer Cannot Discharge Unless START Pressed

Explanation

The developer was not discharged unless the “Start” button was pressed when replacing the developer.

Troubleshooting Procedure

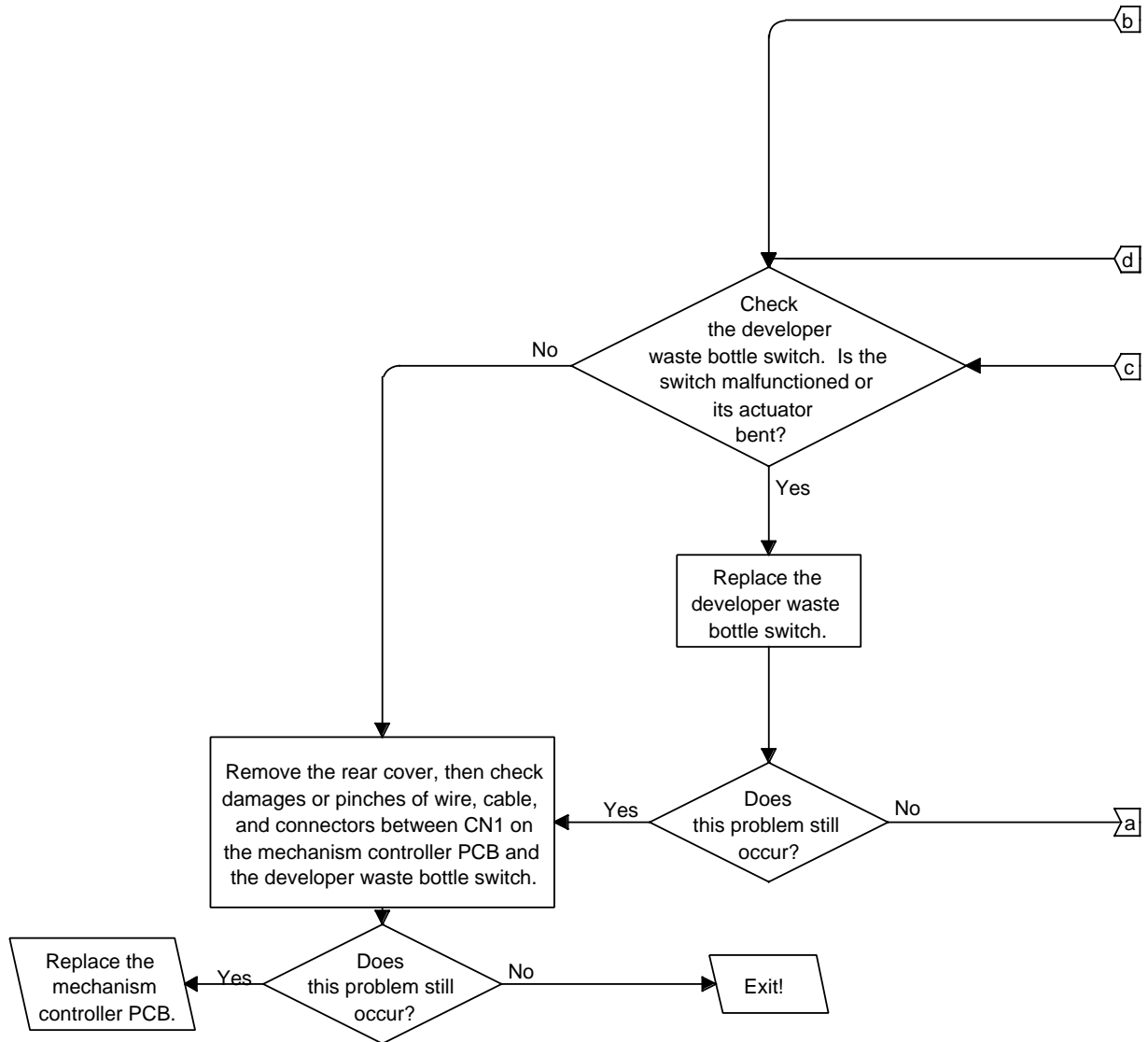

Figure 5-8. Developer Cannot Discharge Unless START Pressed Flow Chart (1 of 2)

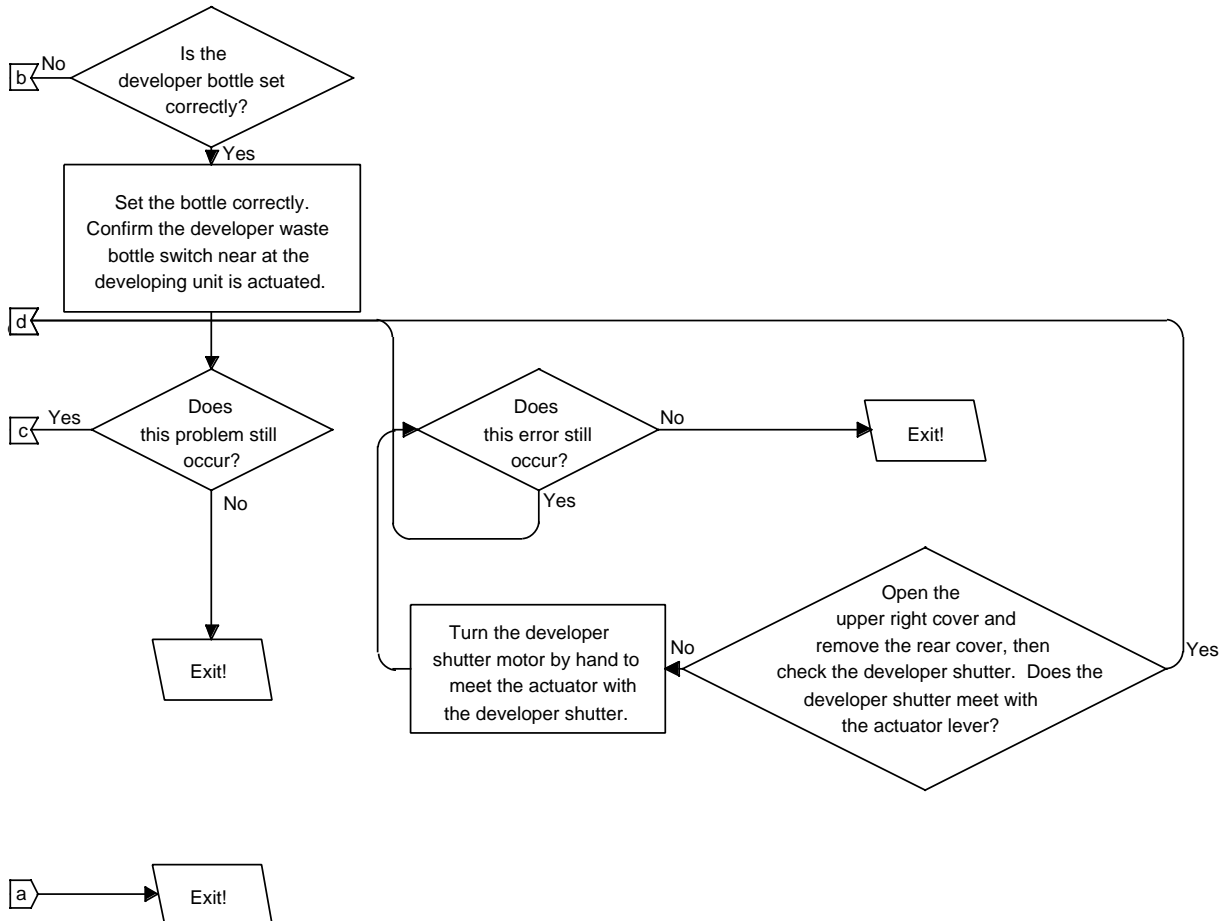

Figure 5-8. Developer Cannot Discharge Unless START Pressed Flow Chart (2 of 2)

Reference Diagrams

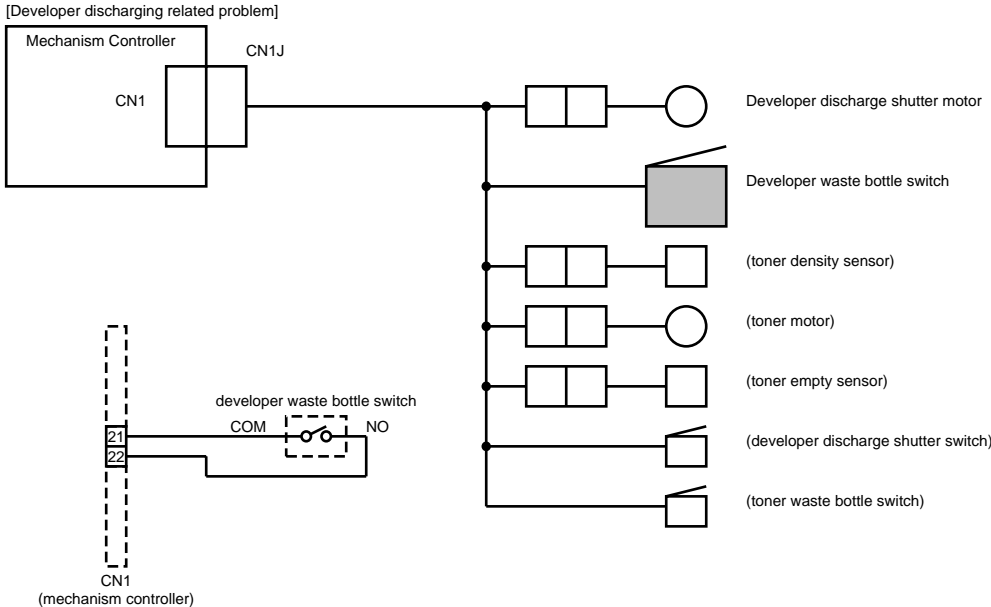

Figure 5-9. Developer Cannot Discharge Interconnections Diagram

5-6. Print Quality Problems

This section provides typical print problem samples, starting, with a good quality print. The rest of the print samples are flawed; the consumable that may be responsible for the flaws is listed below each sample, along with recommended corrective actions.

To establish a good reference for comparison to bad prints, save the test print generated immediately after printer installation.

To use this section.

- (1) If you are dissatisfied with the quality of your prints:
 - a. Clean your printer thoroughly.
 - b. Complete all of the weekly and monthly maintenance tasks.
 - c. Check the quality of your prints regularly.
- (2) If you are still dissatisfied with your print quality:
 - a. Print a page and compare it to the samples in this appendix.
 - b. Generate test prints to compare more directly your prints with those in this section.
 - c. Identify a print sample included in this section that has the same flaws as your test print.
 - d. Review and complete the actions listed under the print sample in the order in which they are listed generating a test print after you complete each action.
 - e. Check the print's quality after each test print. If the flaw(s) are still present, continue to the next action in the list. If the flaws are repaired, you need not complete the remaining actions.
- (3) If you complete all the recommended actions, including changing the consumable, and the print quality does not improve, call a field service technician to address the problem.

5-6.1. General Approach to Print Quality Problems

Explanation

At any print quality problems, check the following items before starting troubleshoot.

Troubleshooting Procedure

1. Check whether the paper being used meets standard (especially for thickness, smoothness, foreign particles, moisture, or something sticking the paper each other).
2. Check whether the paper is handled correctly (especially for creases or wrinkles).
3. Check whether the environment both for the printer and the paper itself meets standard (especially for humidity).
4. Check whether the rollers and the paper guides are clean (especially for scattered toner or developer, accumulated paper powder and paper pieces).

5-6.2. Good Quality Print

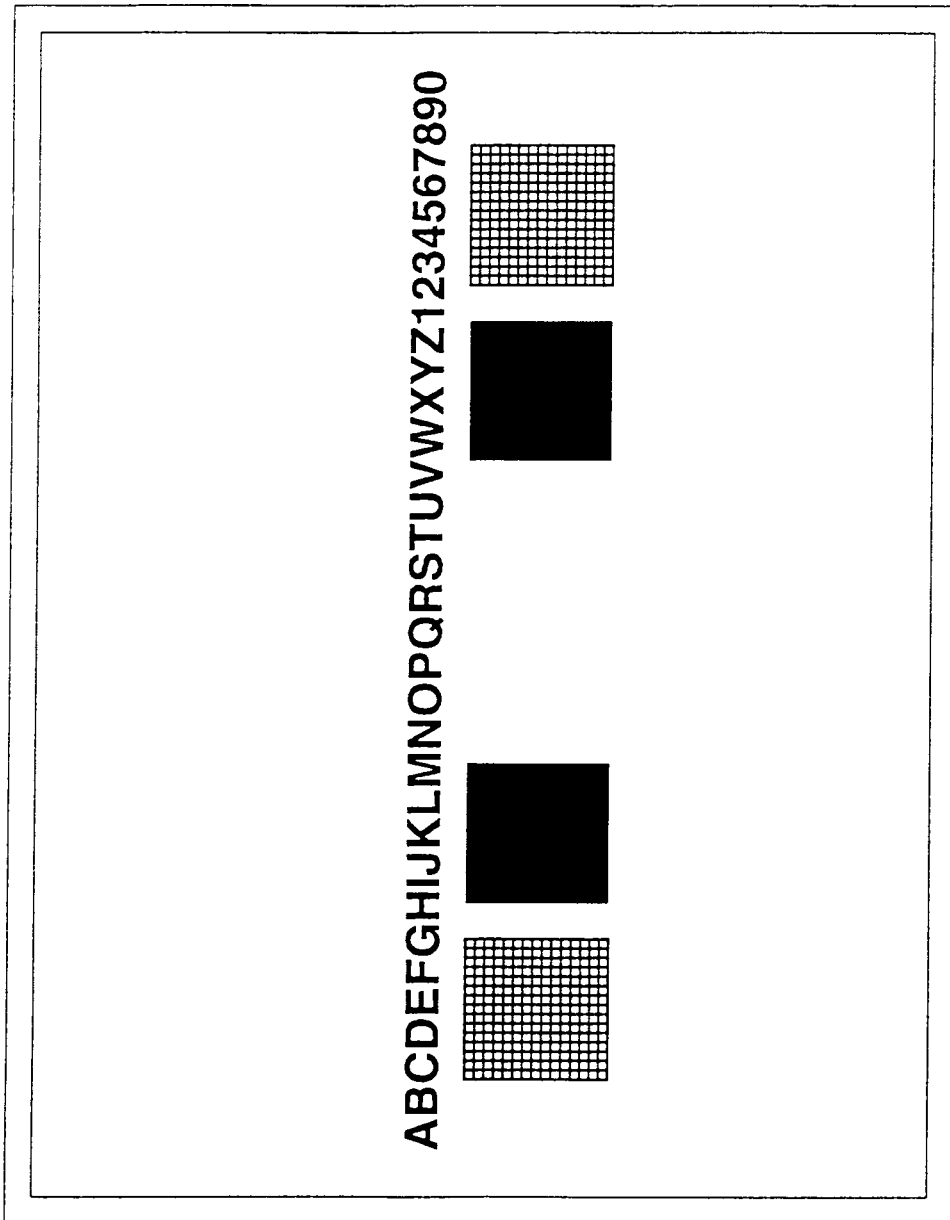

Figure 5-10. Good Quality Print Example

Explanation

This print quality sample indicates no printing problems.

Troubleshooting Procedure

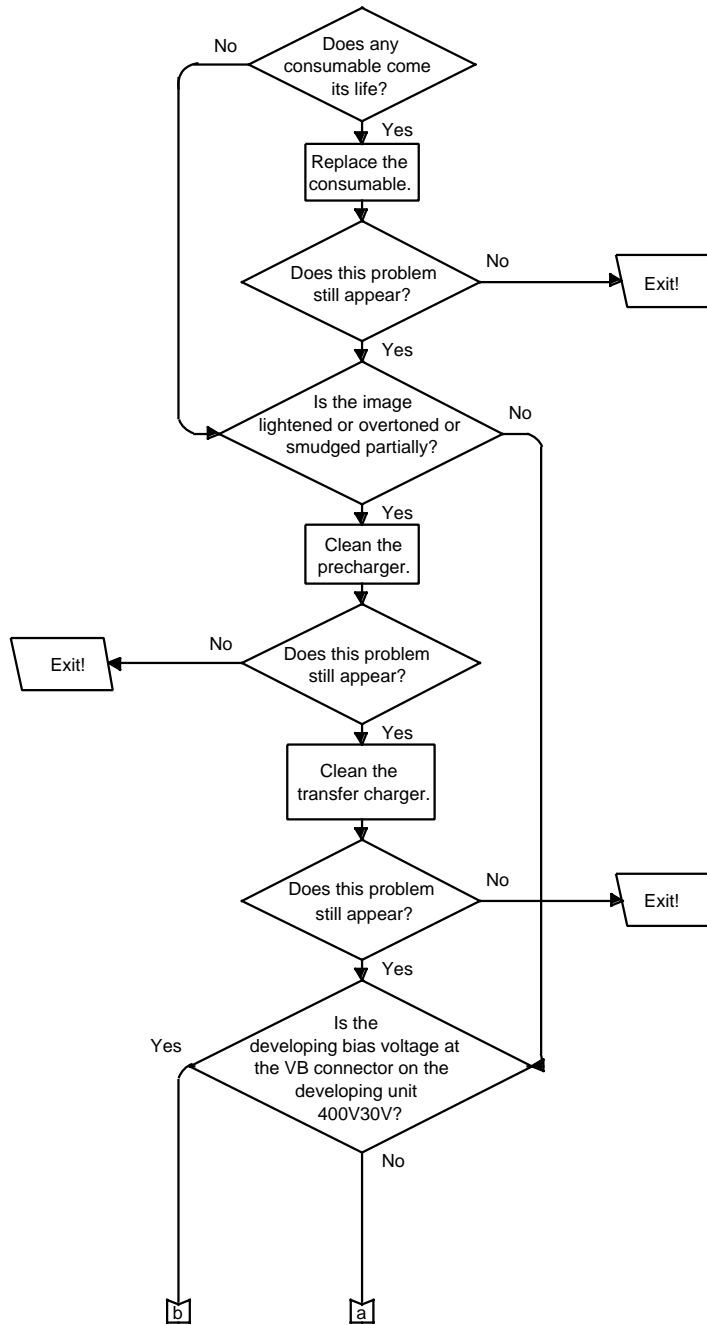

Figure 5-11. Background Print Flow Chart (1 of 3)

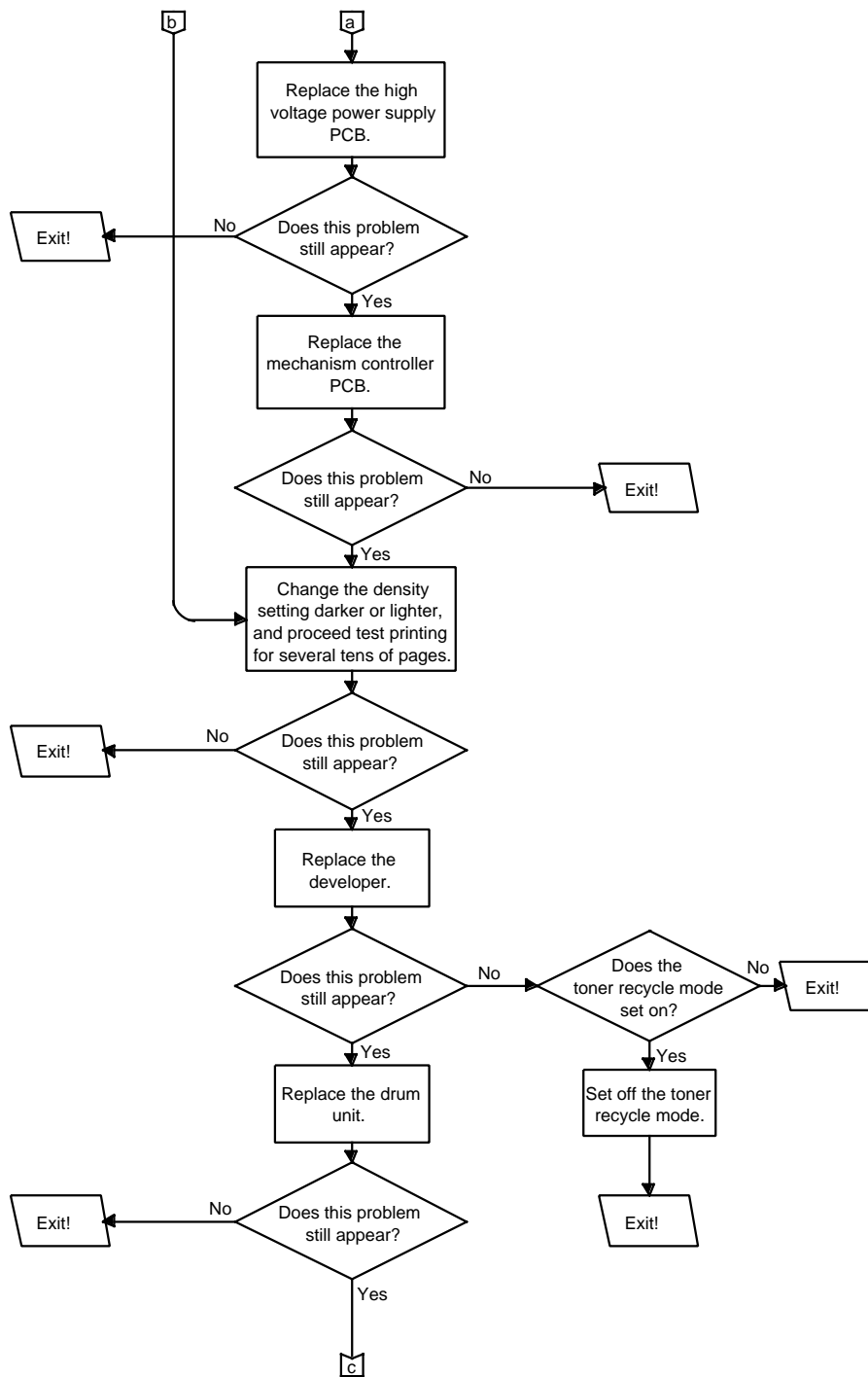

Figure 5-11. Background Print Flow Chart (2 of 3)

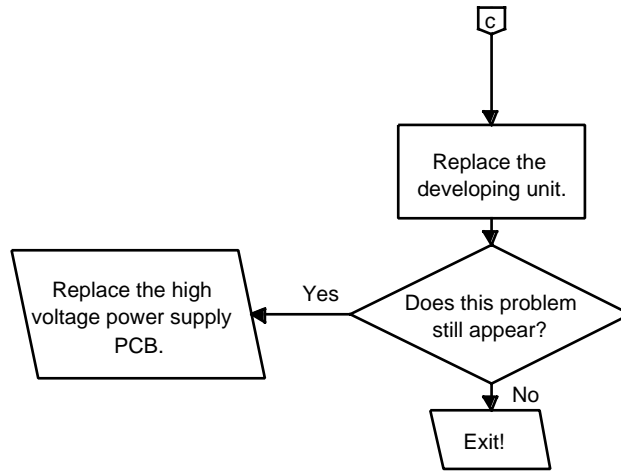

Figure 5-1. Background Print Flow Chart (3 of 3)

5-6.3. Black or Dark Print

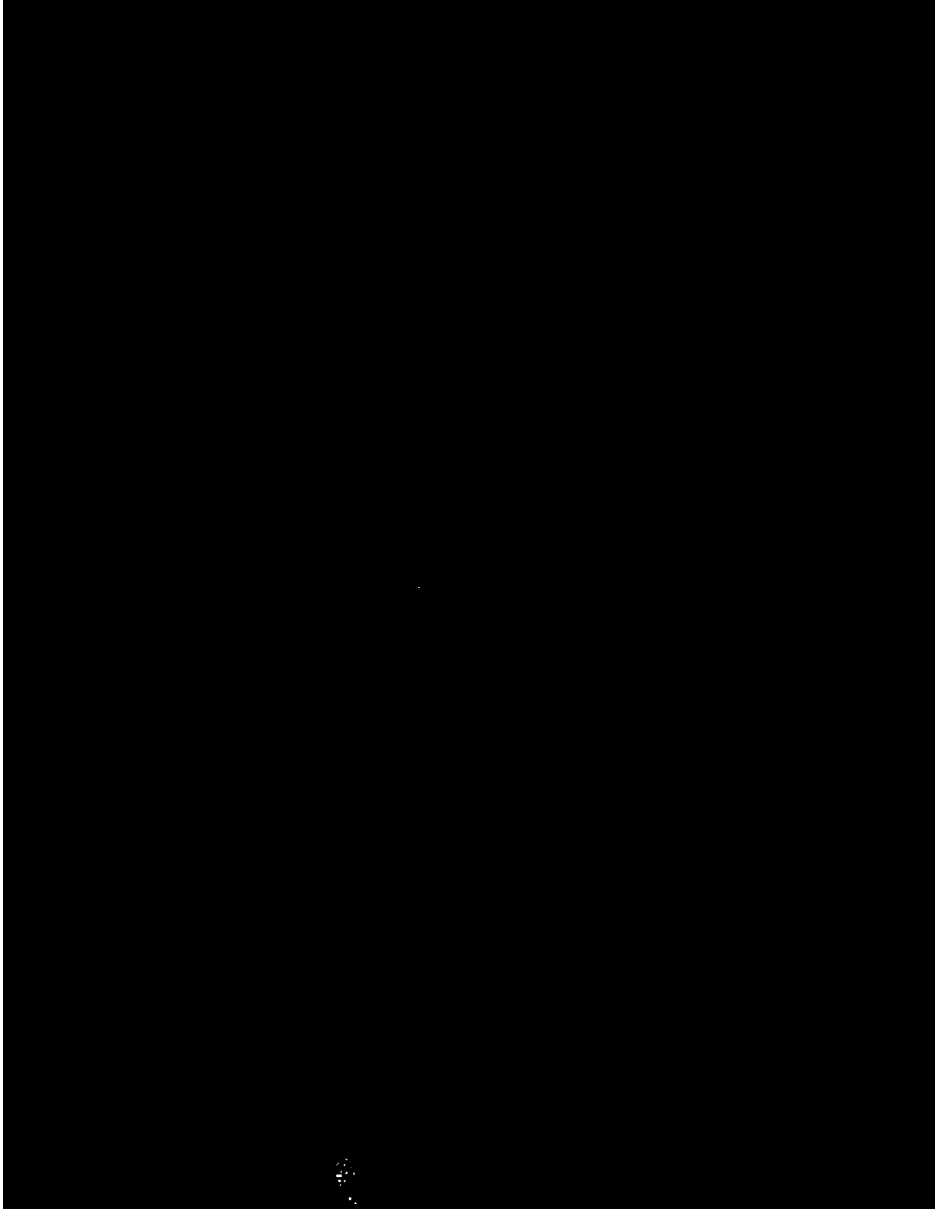

Figure 5-2. Black or Dark Print Example

Explanation

Black or very dark print with no visible images.

Troubleshooting Procedure

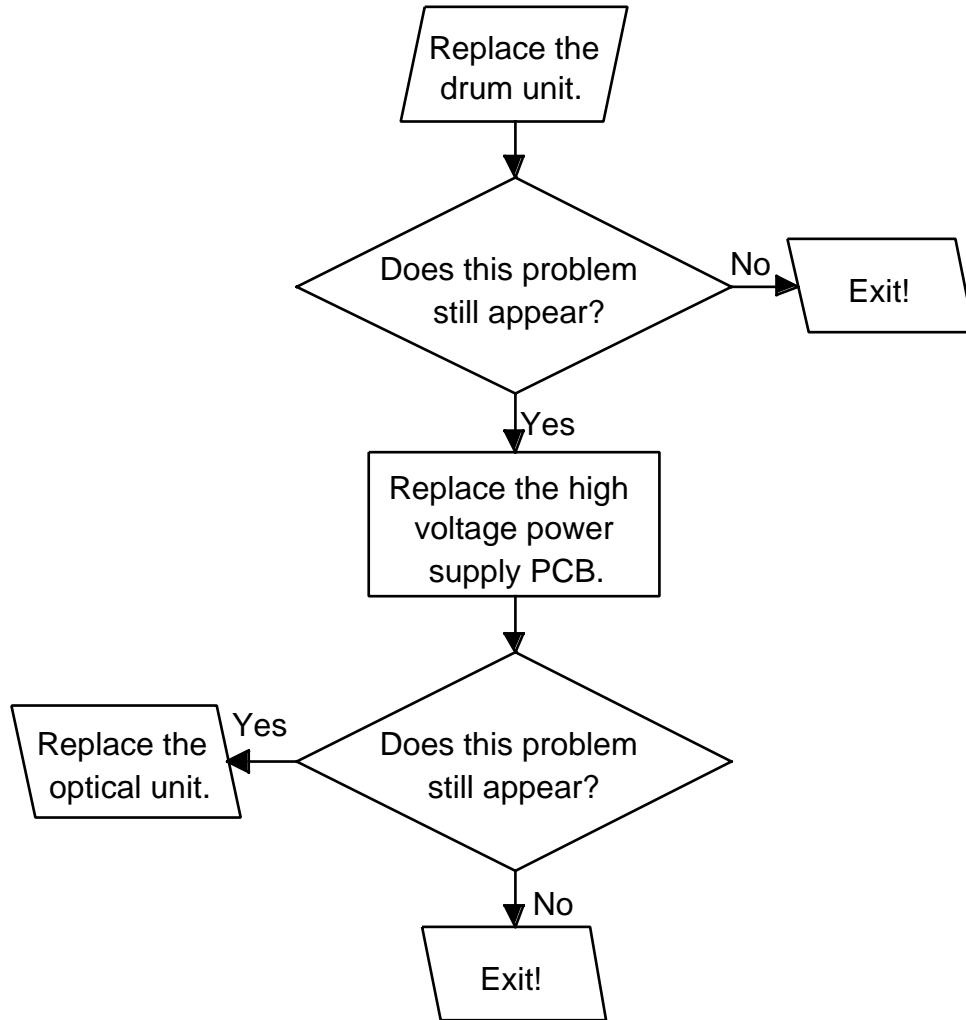

Figure 5-3. Black or Dark Print Flow Chart

5-6.4. Blank Print

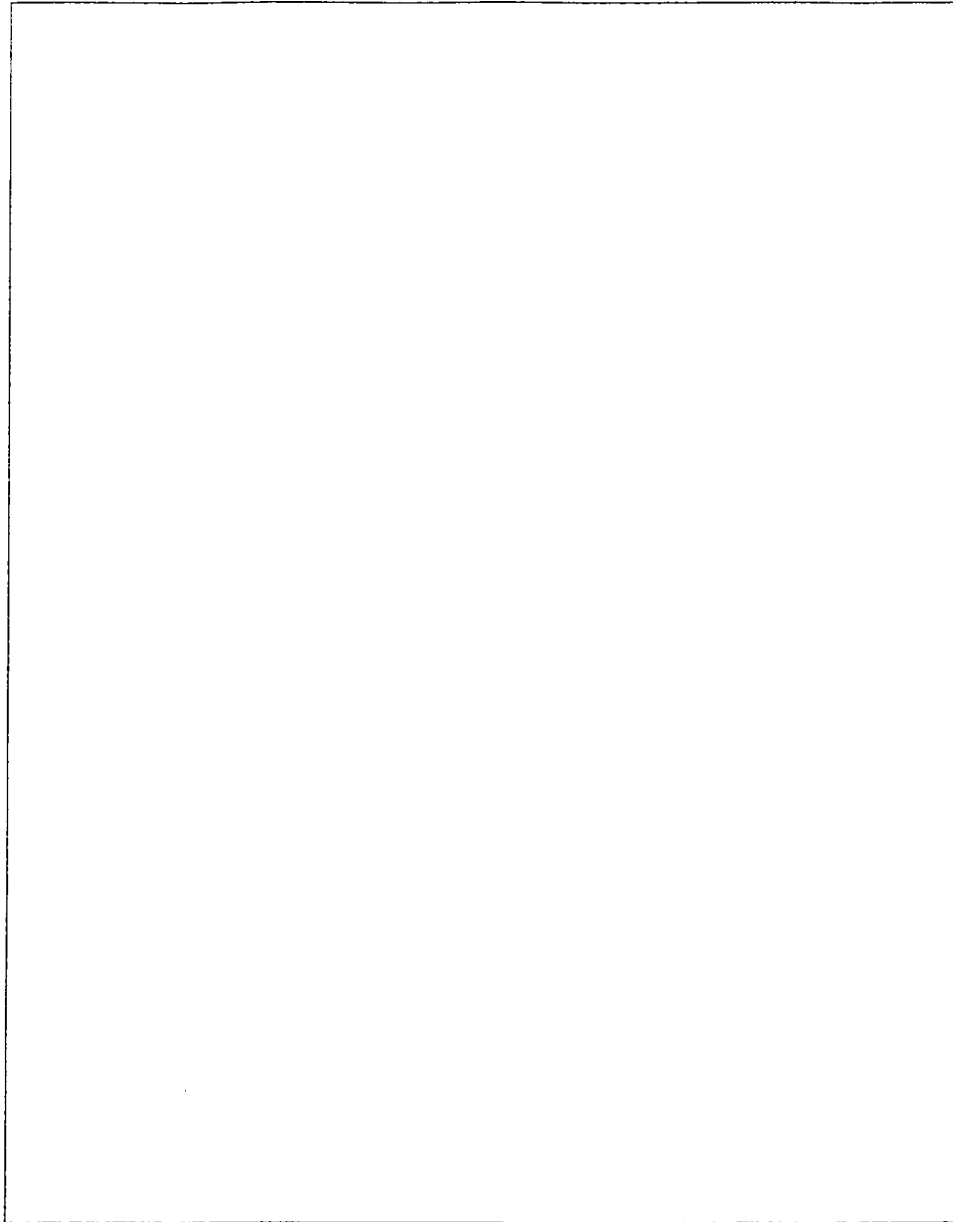

Figure 5-4. Blank Print Example

Explanation

No image or characters, and the paper is not discolored.

Troubleshooting Procedure

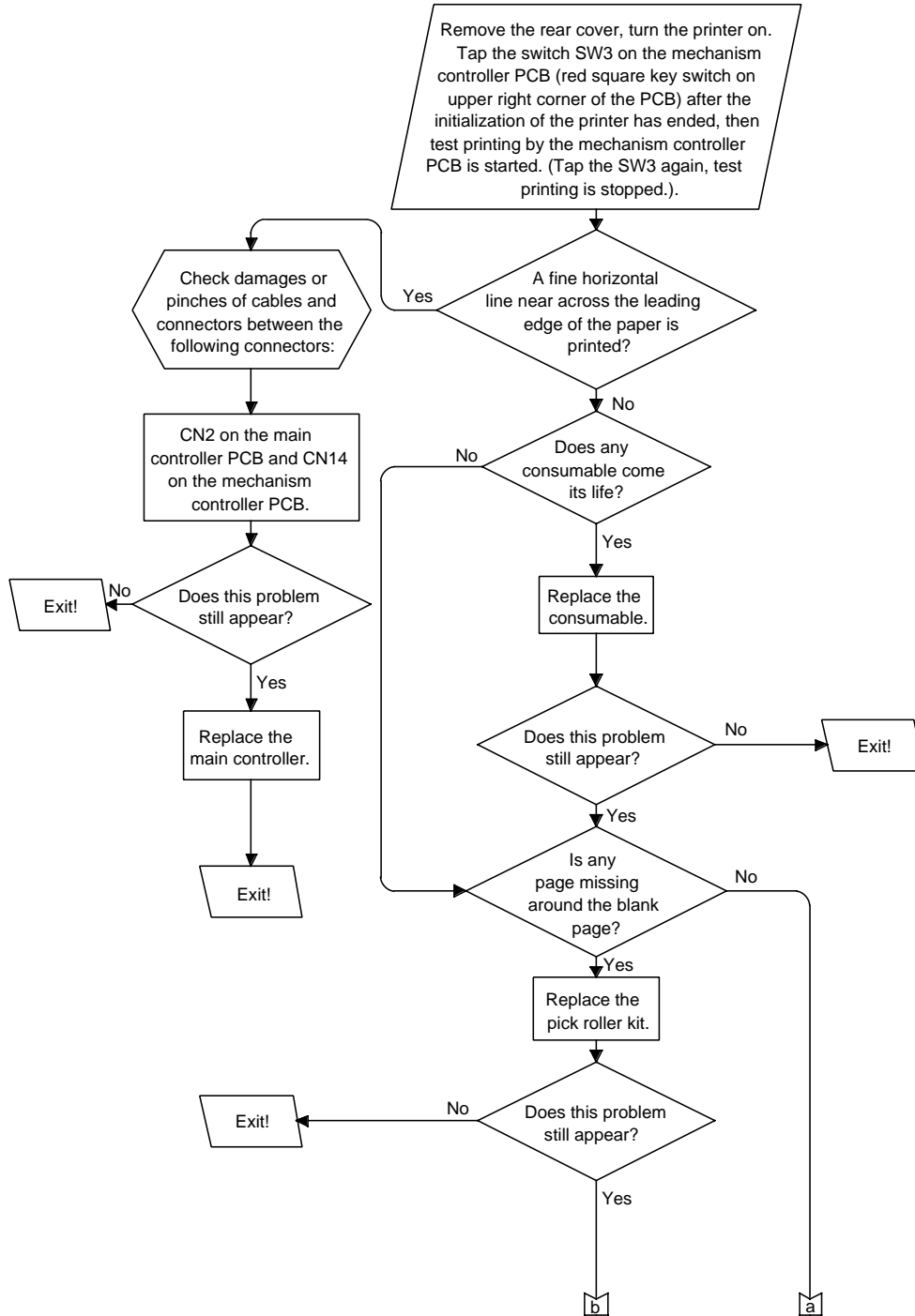

Figure 5-5. Blank Print Flow Chart (1 of 3)

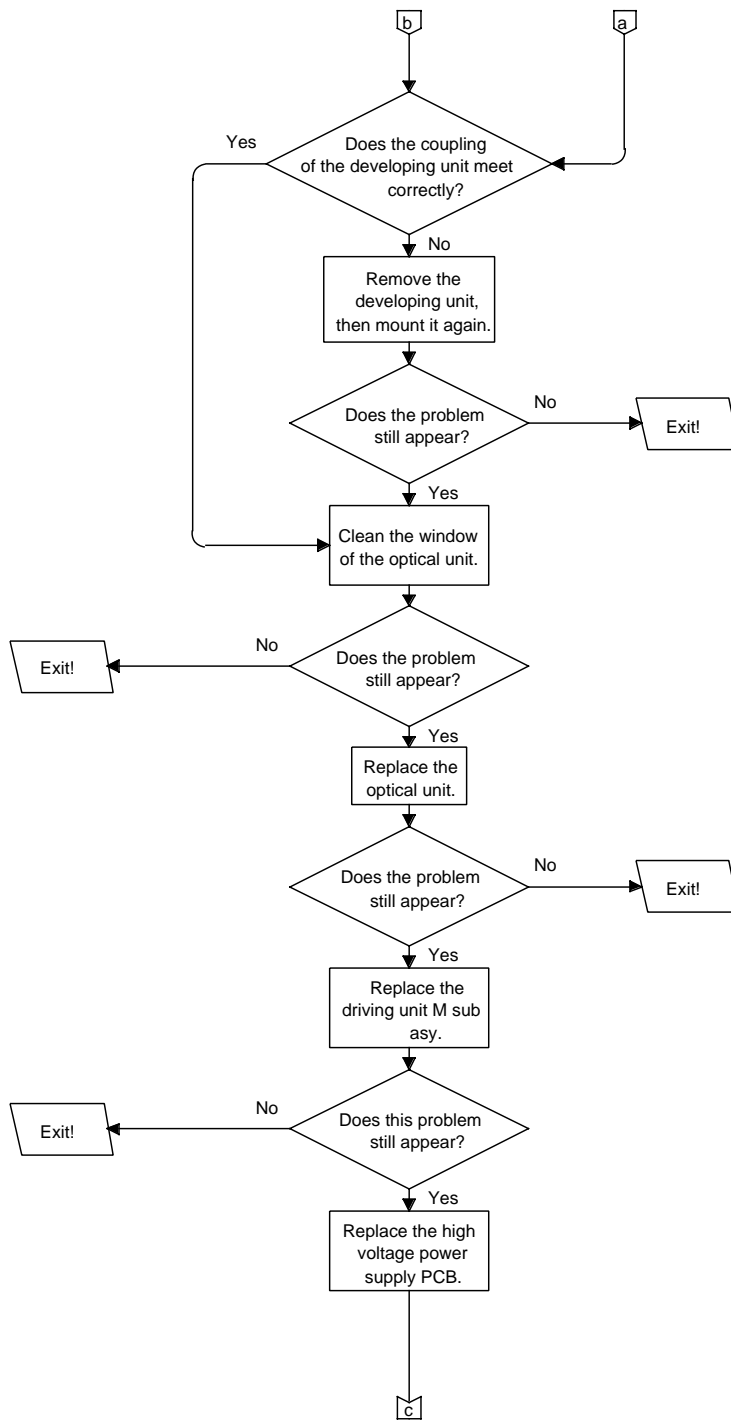

Figure 5-5. Blank Print Flow Chart (2 of 3)

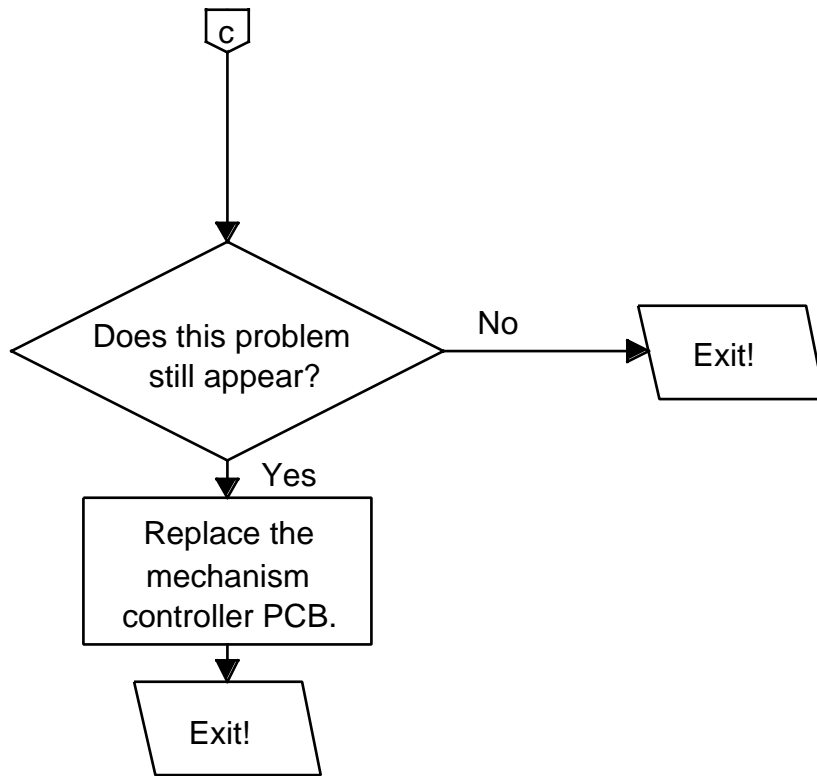

Figure 5-5. Blank Print Flow Chart (3 of 3)

5-6.5. Blank Vertical Bands Print

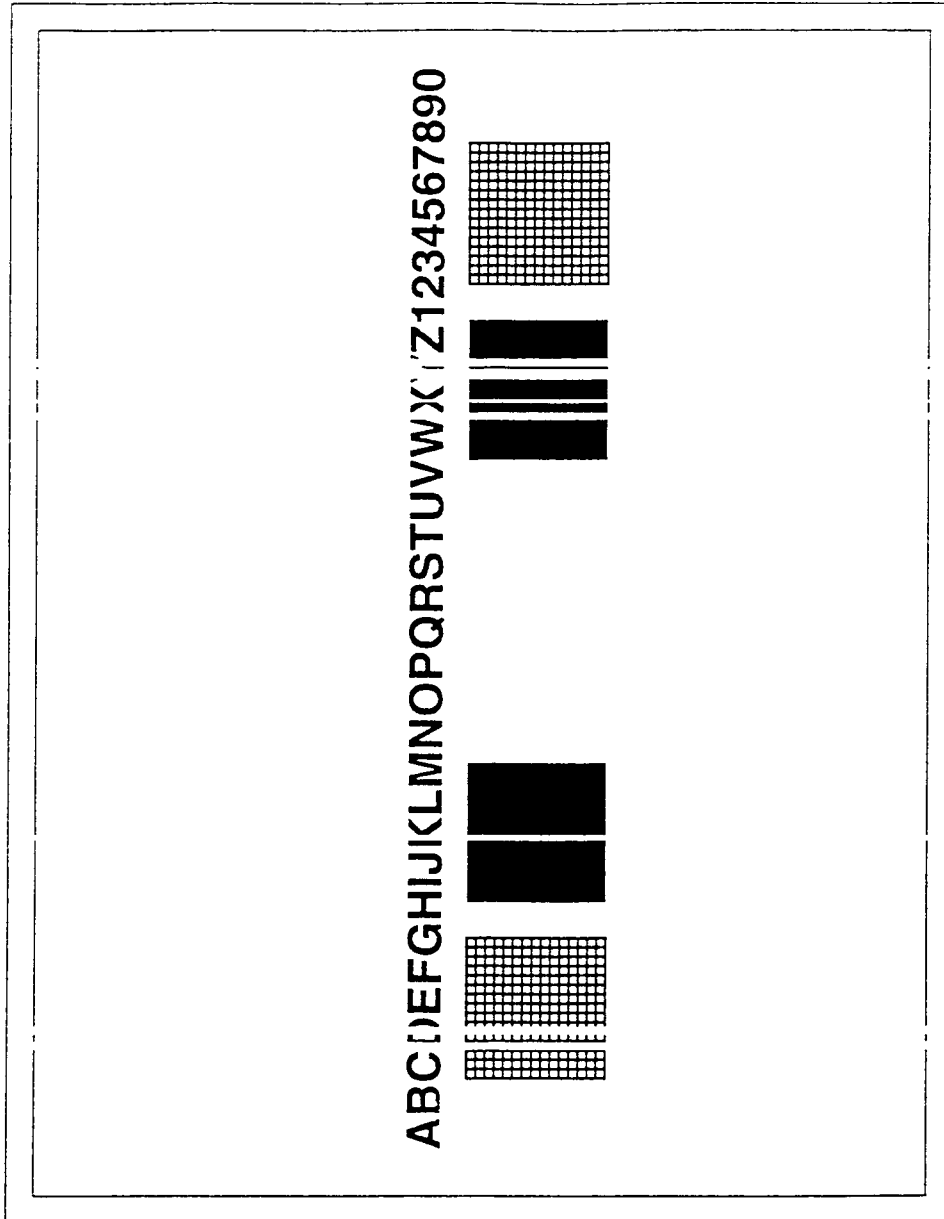

Figure 5-6. Blank Vertical Bands Print Example

Explanation

One or more vertical bands.

Troubleshooting Procedure

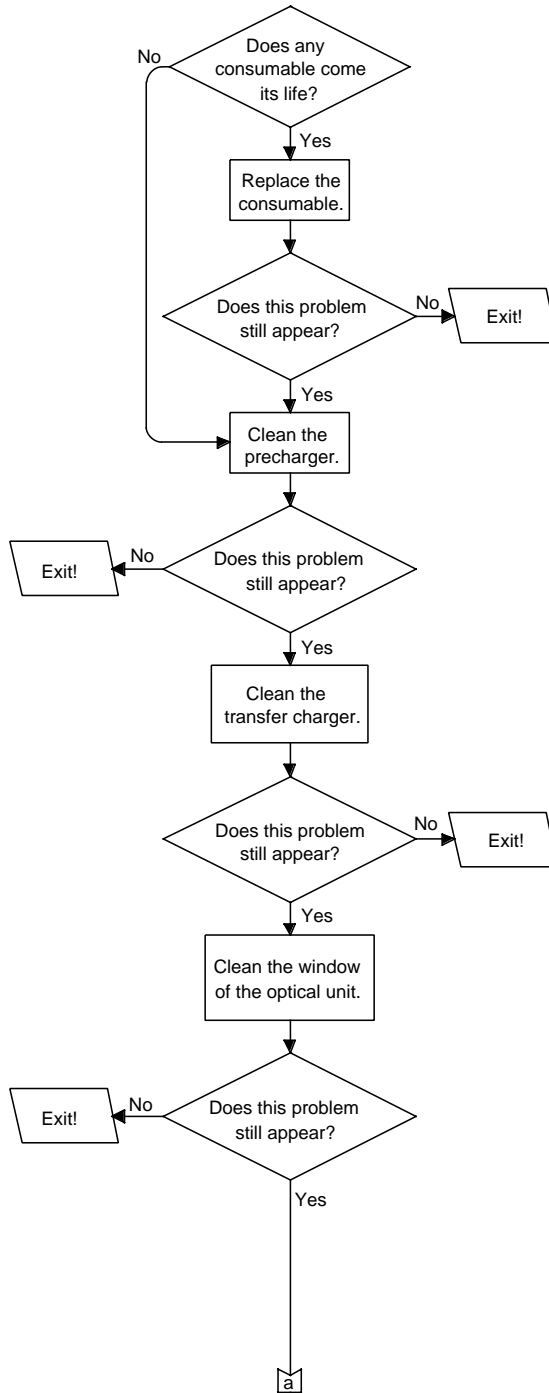

Figure 5-7. Blank Vertical Bands Print Flow Chart (1 of 3)

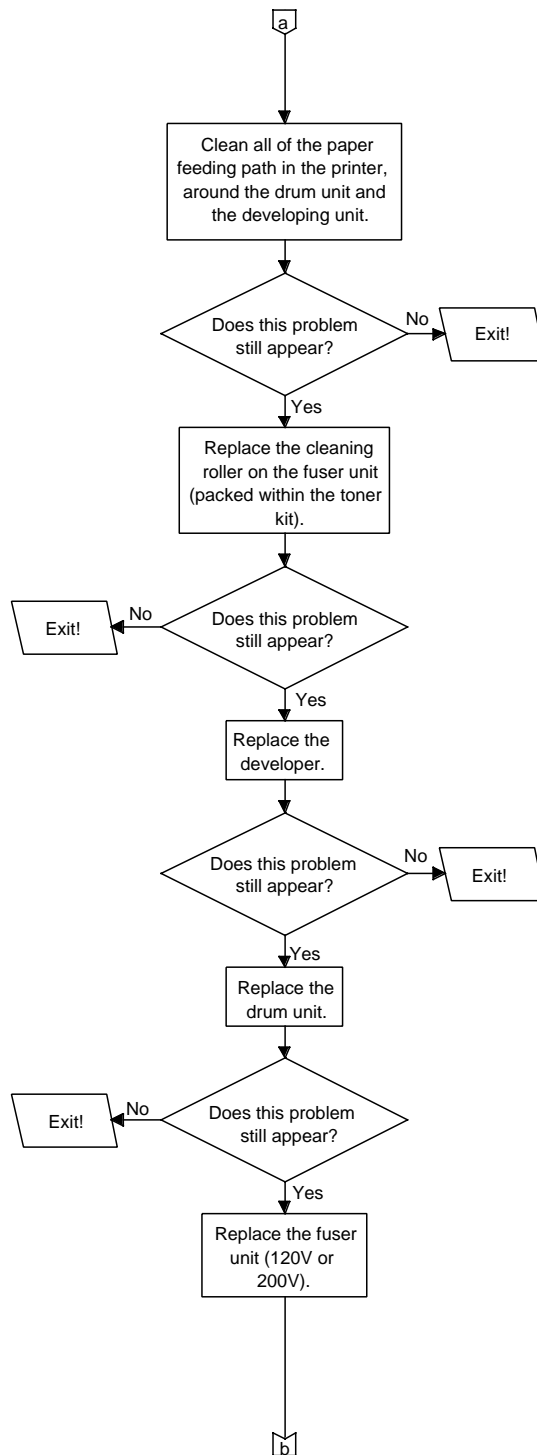

Figure 5-7. Blank Vertical Bands Print Flow Chart (2 of 3)

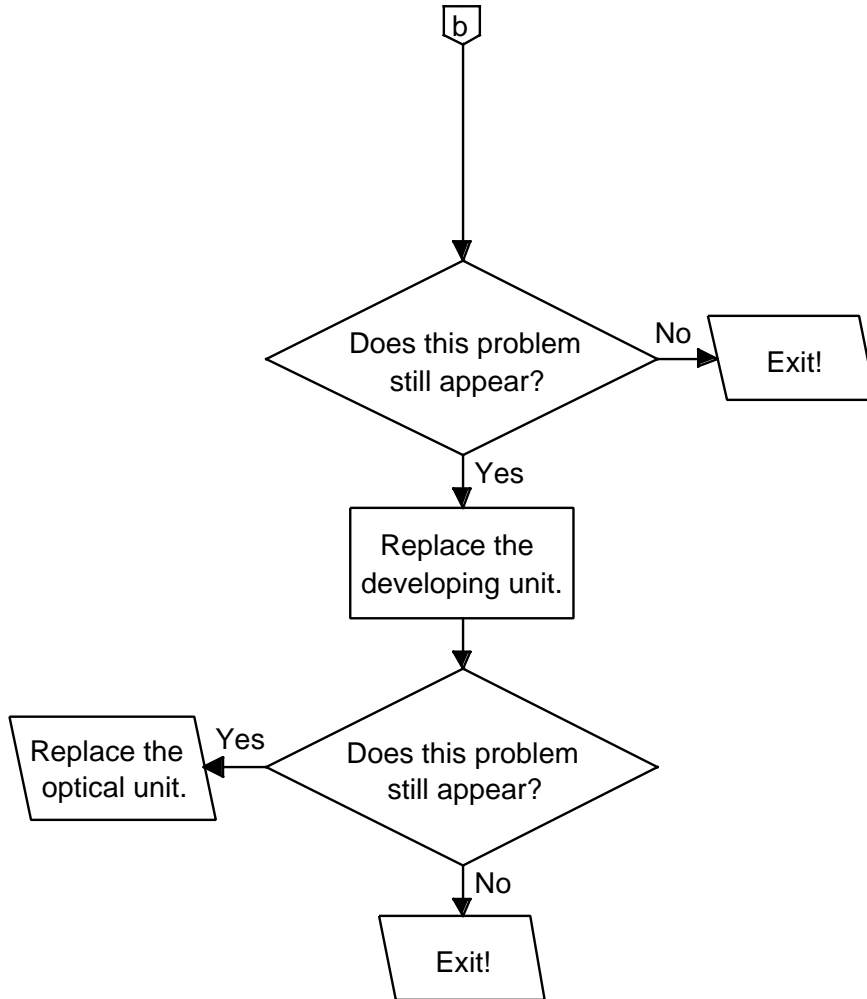

Figure 5-7. Blank Vertical Bands Print Flow Chart (3 of 3)

5-6.6. Blurred Images or Blurred Characters Print

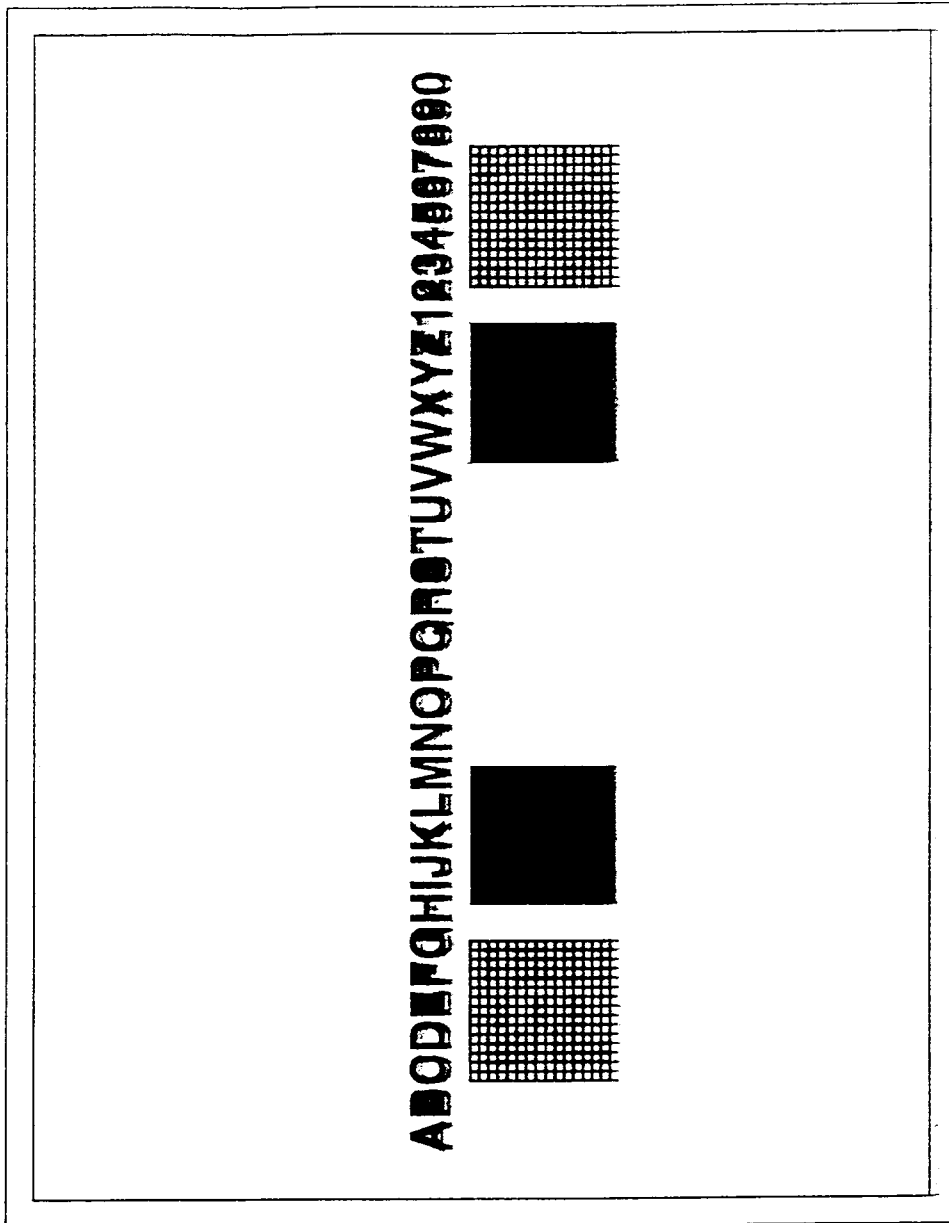

Figure 5-8. Blurred Images or Blurred Characters Print Example

Explanation

The images or characters are not clear. The lower edges of images, characters, or both are extended and possibly smeared.

Troubleshooting Procedure

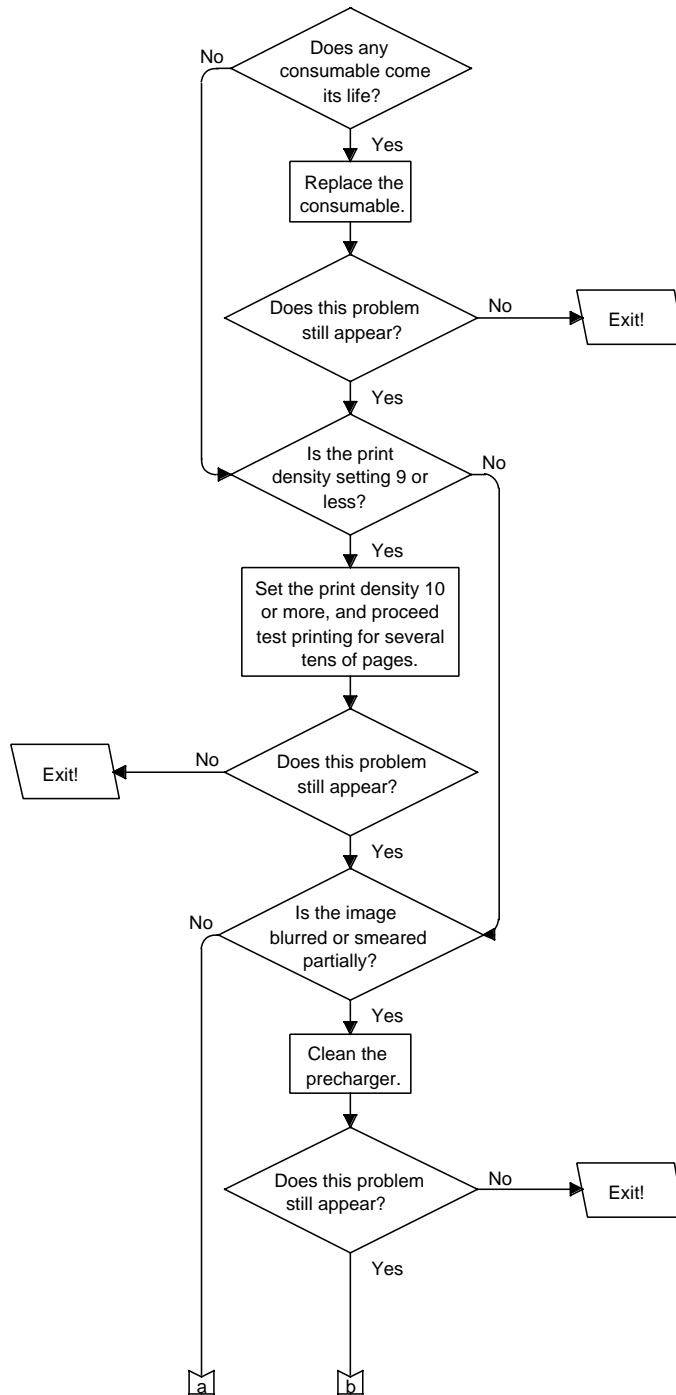

Figure 5-9. Blurred Images or Blurred Characters Print Flow Chart (1 of 3)

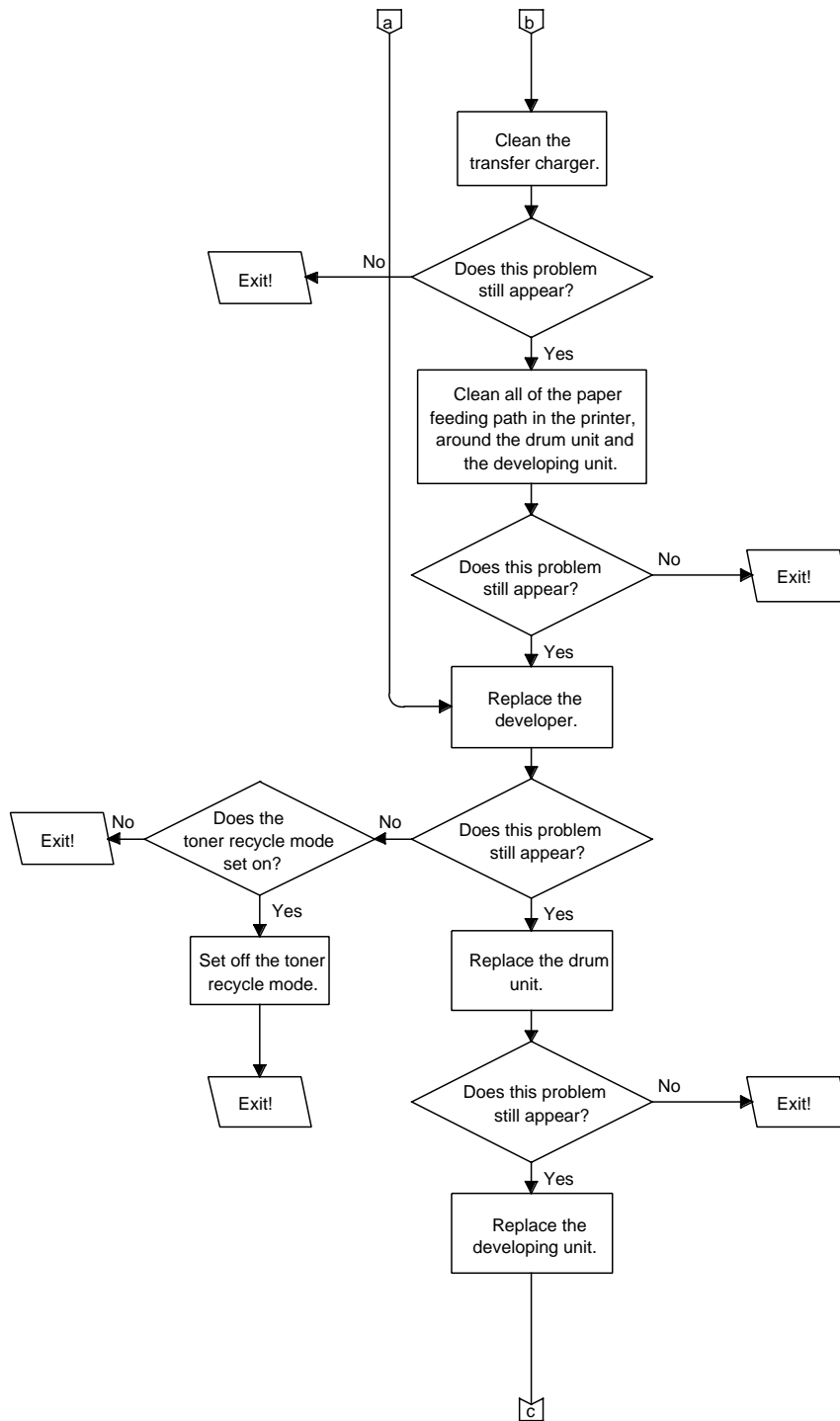

Figure 5-9. Blurred Images or Blurred Characters Print Flow Chart (2 of 3)

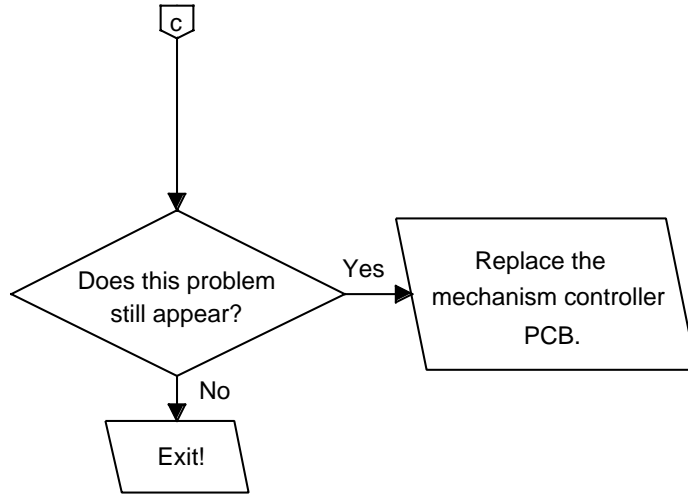

Figure 5-9. Blurred Images or Blurred Characters Print Flow Chart (3 of 3)

5-6.7. Dark-specks, Dark-lines, or Dark-areas Print

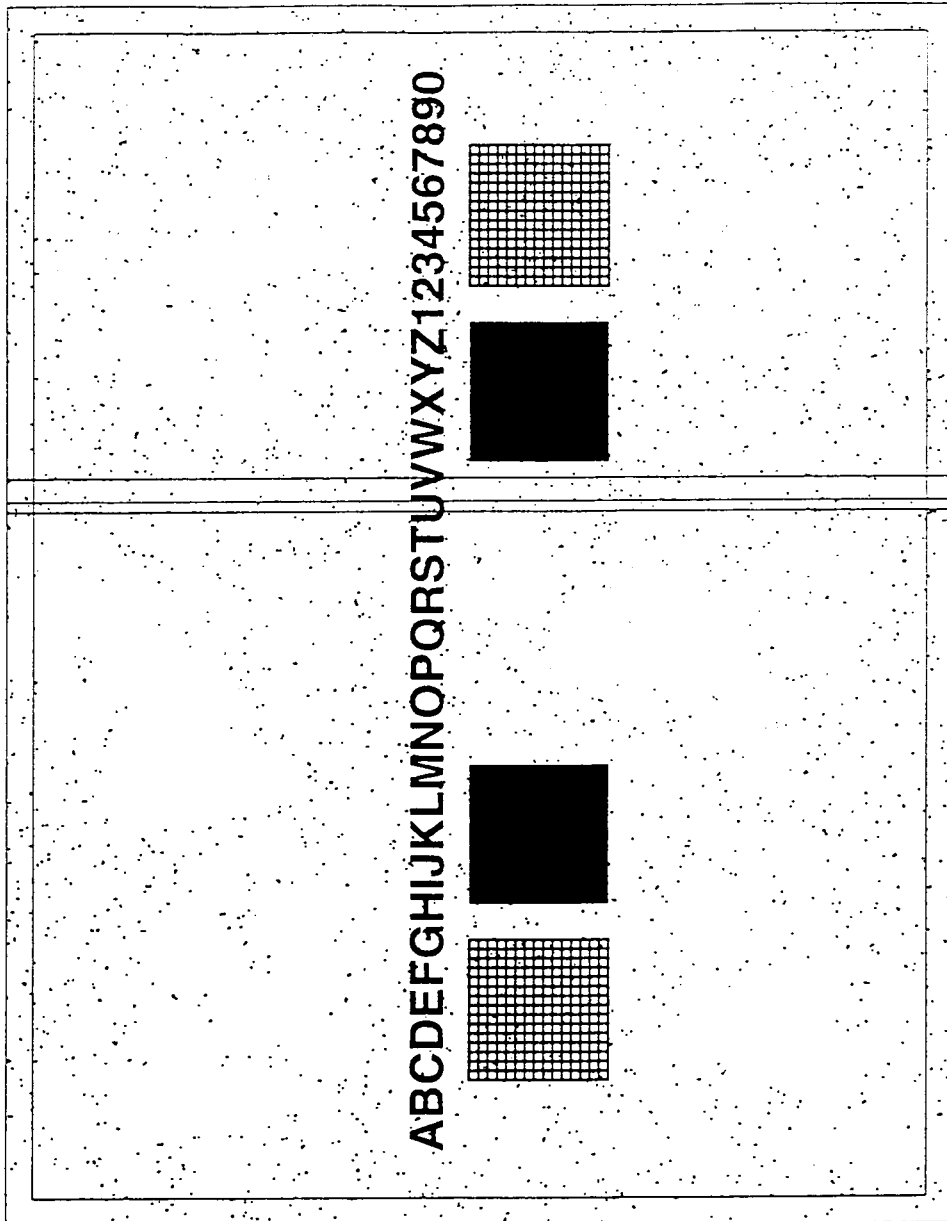

Figure 5-10. Dark-specks, Dark-lines, or Dark-areas Print Example

Troubleshooting Procedure

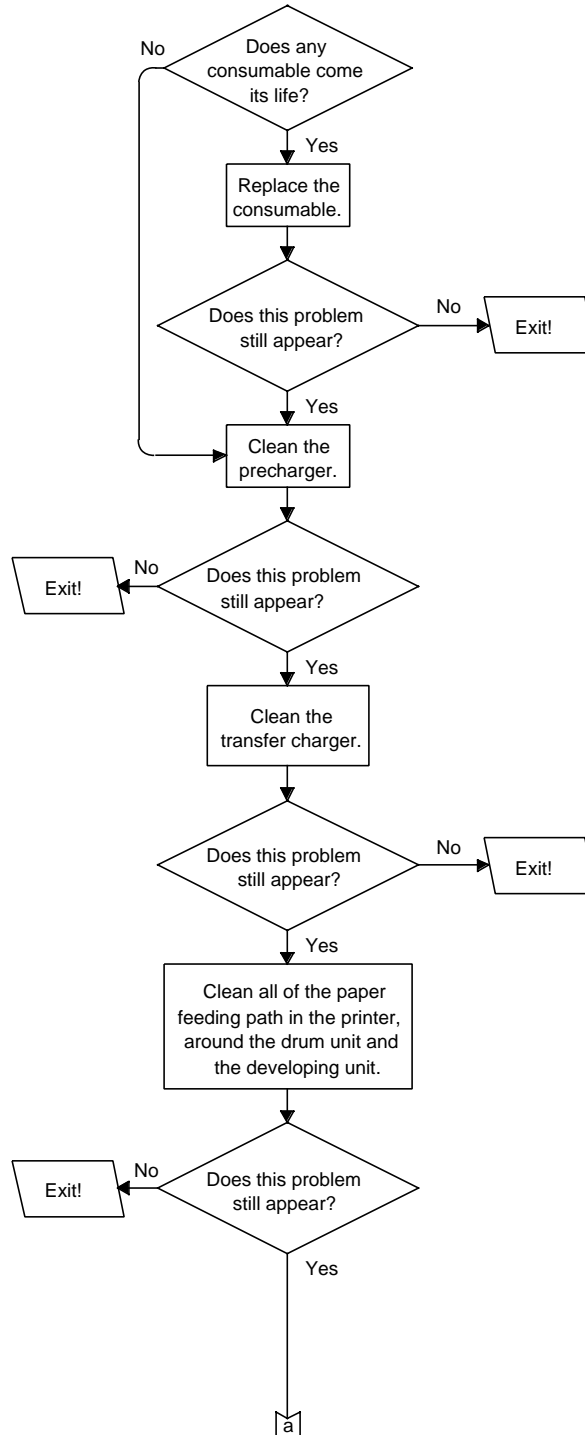

Figure 5-11. Dark-specks, Dark-lines, or Dark-areas Print Flow Chart (1 of 2)

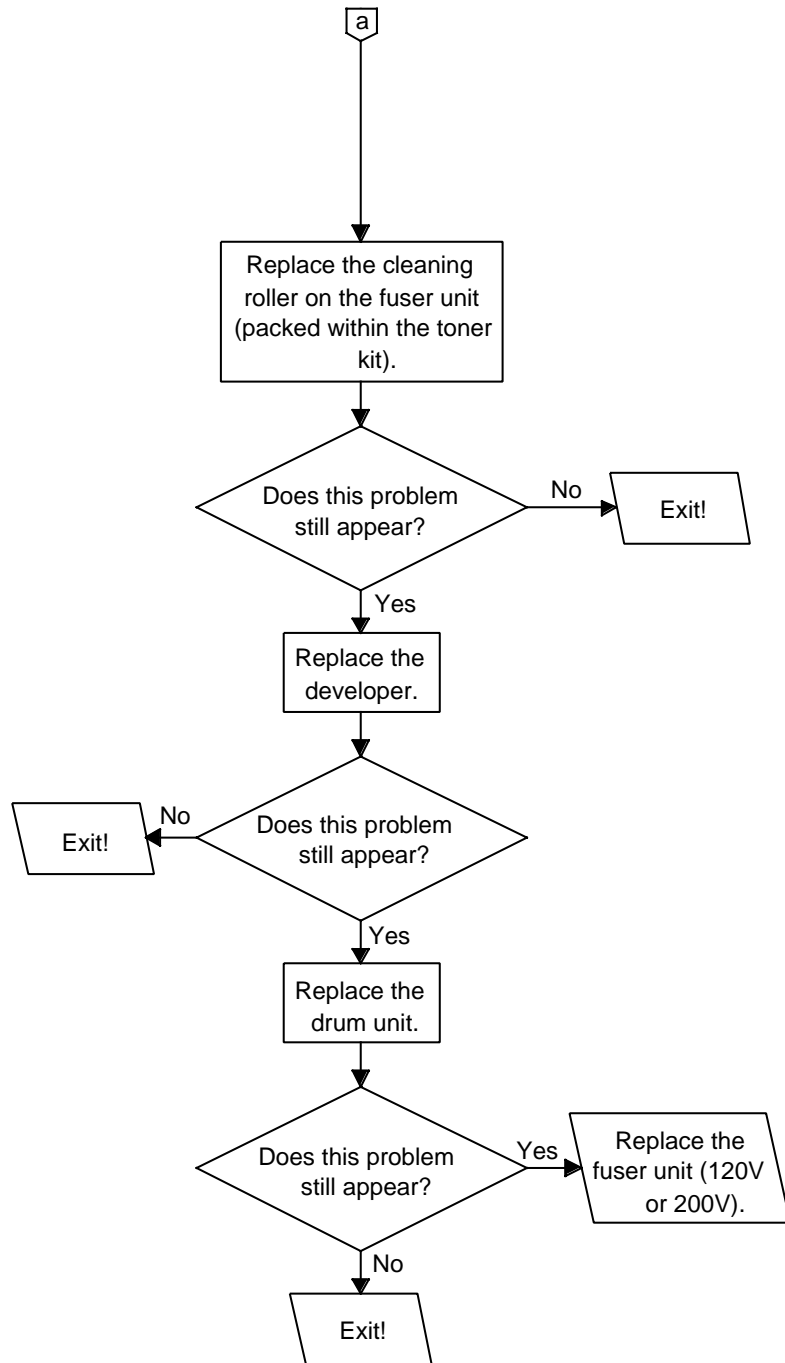

Figure 5-11. Dark-specks, Dark-lines, or Dark-areas Print Flow Chart (2 of 2)

5-6.8. Dark Vertical Lines Print

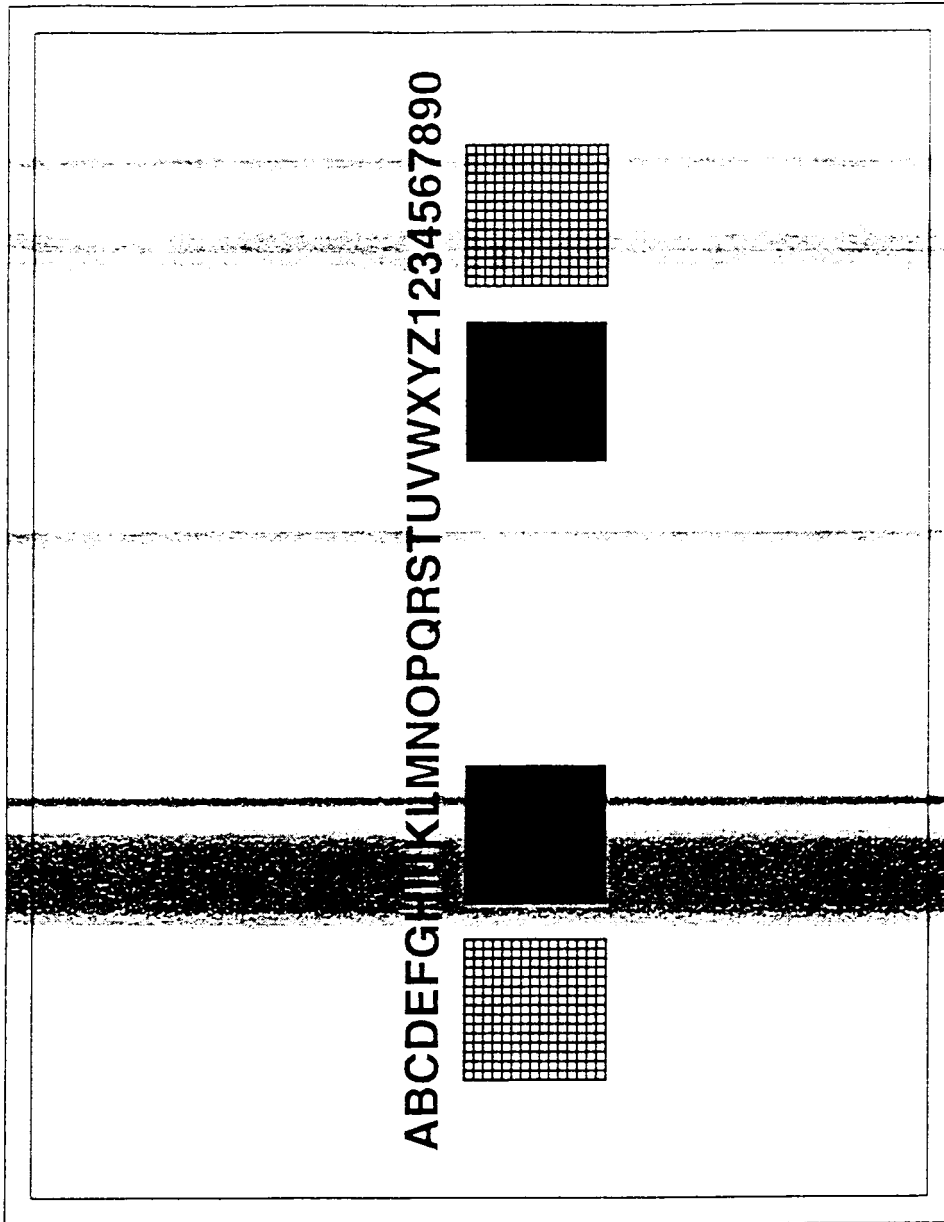

Figure 5-12. Dark Vertical Lines Print Example

Troubleshooting Procedure

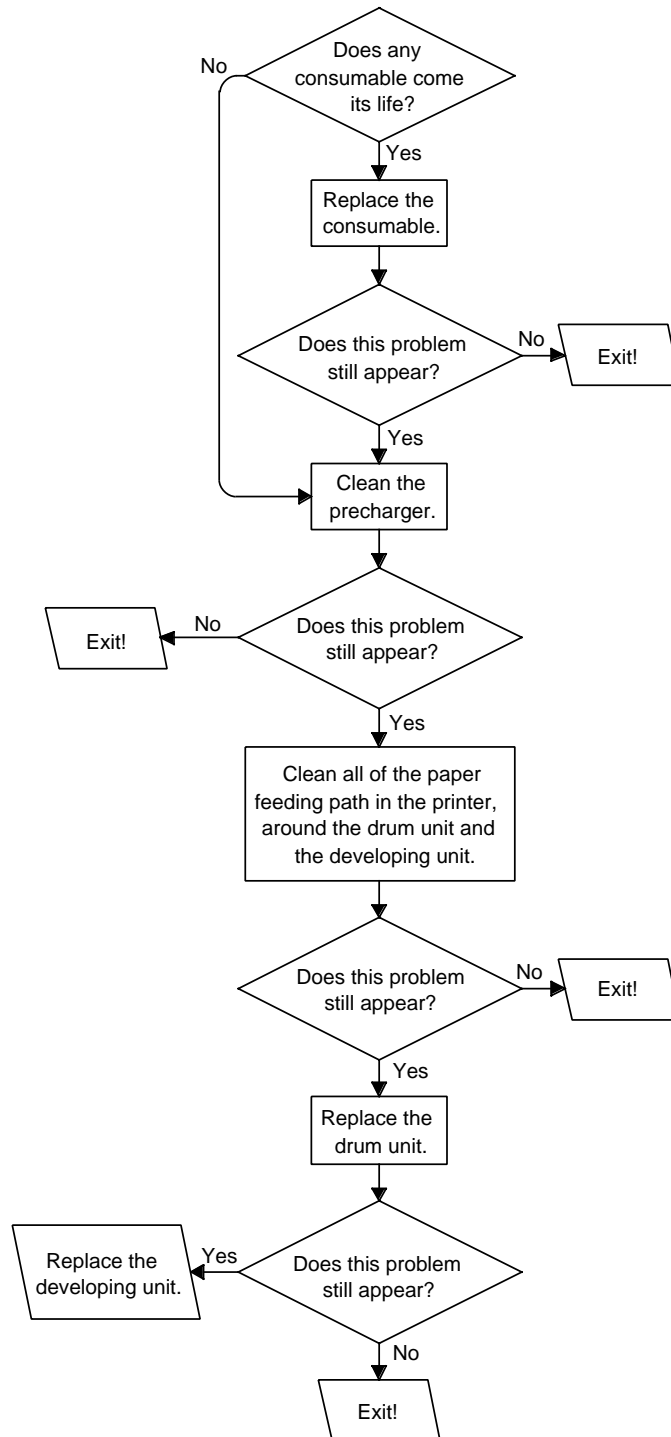

Figure 5-13. Dark Vertical Lines Print Flow Chart

5-6.9. Fusing Problems Print

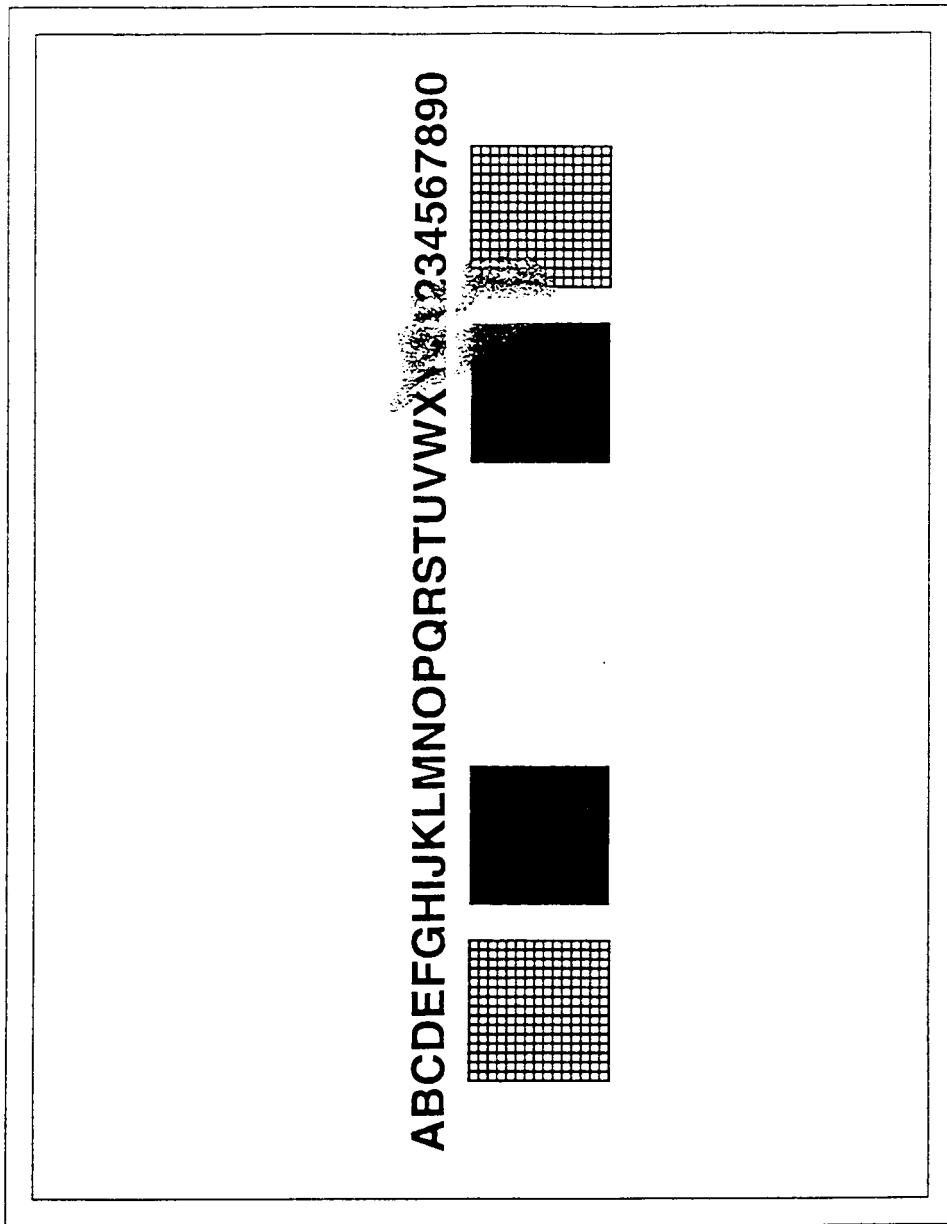

Figure 5-14. Fusing Problems Print Example

Troubleshooting Procedure

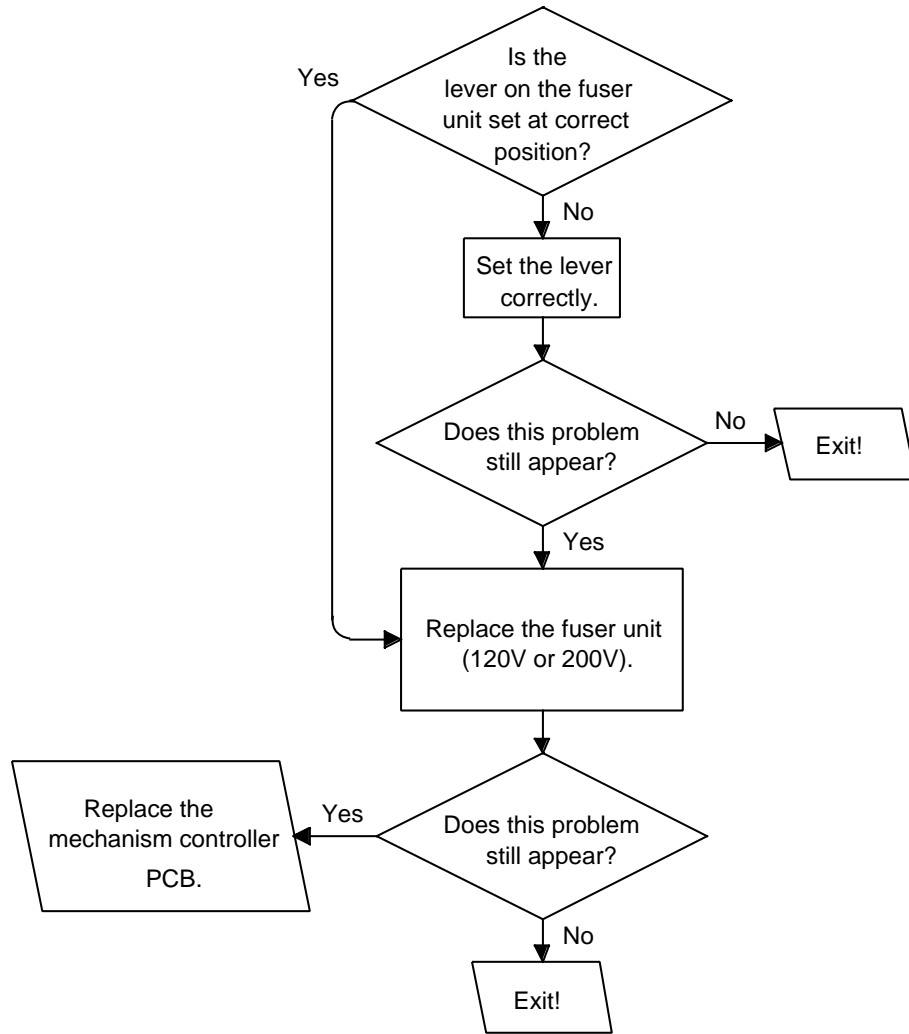

Figure 5-15. Fusing Problems Print Flow Chart

5-6.10. Light Print With Background

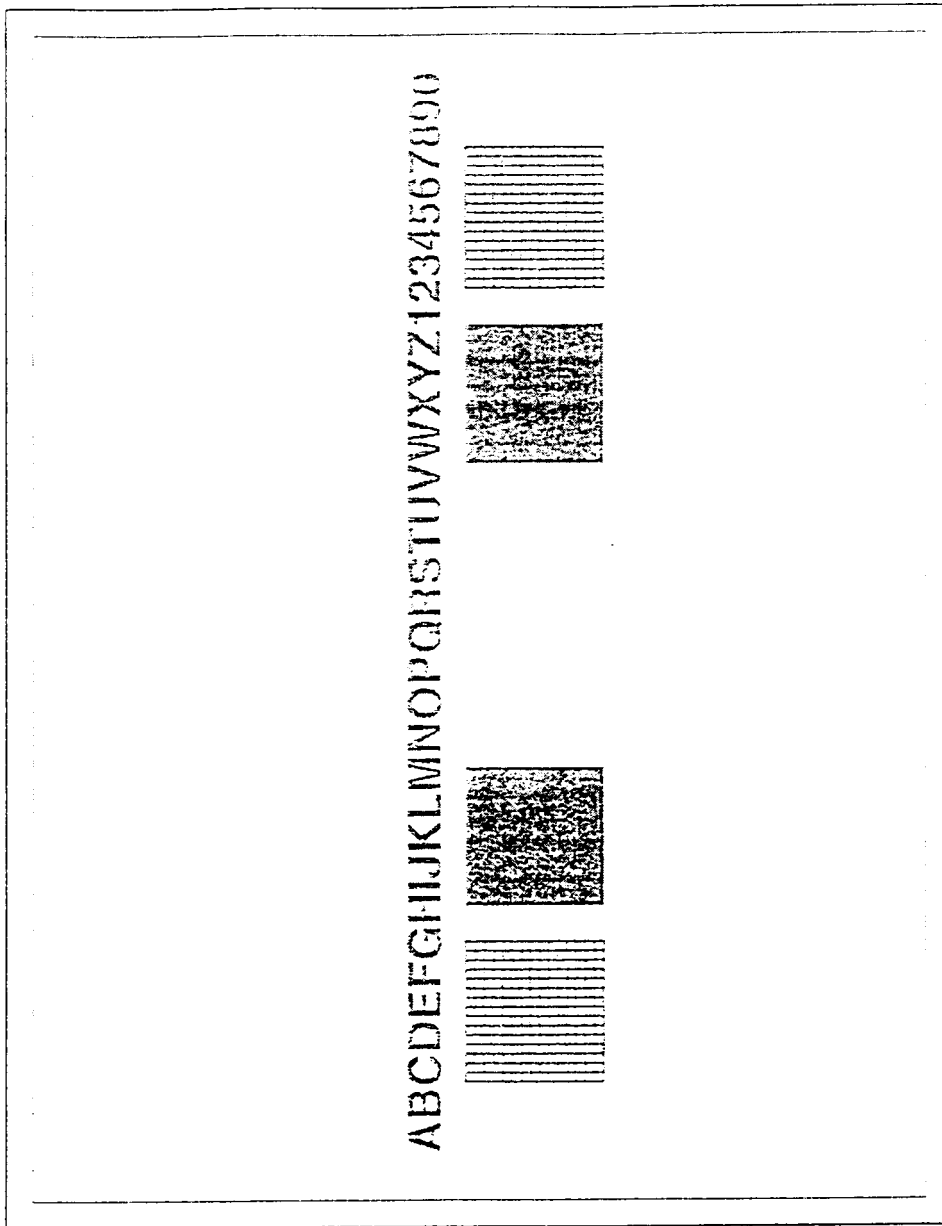

Figure 5-16. Light Print With Background Example

Troubleshooting Procedure

<020> Is the print density setting 9 or less? <Y:022, N:030>

<022> Set the print density 10 or more, and proceed test printing for several tens of pages.

<024> Does this problem still appear? <Y:030, N:Exit>

<030> Does any consumable come its life? <Y:032, N:040>

<032> Replace the consumable.

<034> Does this problem still appear? <Y:040, N:Exit>

<040> Is the image lightened partially? <Y:042, N:060>

<042> Clean the precharger.

<044> Does this problem still appear? <Y:046, N:Exit>

<046> Clean the transfer charger.

<048> Does this problem still appear? <Y:050, N:Exit>

<050> Clean the window of the optical unit (refer 4-172).

<052> Does this problem still appear? <Y:060, N:Exit>

<055> Is the developing bias voltage at the VB connector on the developing unit 400V +/- 30V?
<Y:060, N:100>

<060> Replace the developer.

<062> Does this problem still appear? <Y:080, N:064>

<064> Does the toner recycle mode set on? <Y:066, N:Exit>

<066> Set off the toner recycle mode.

<068> Exit.

<080> Replace the drum unit.

<082> Does this problem still appear? <Y:090, N:Exit>

<090> Replace the optical unit.

<092> Does this problem still appear? <Y:100, N:Exit>

<100> Replace the high voltage power supply PCB.

<102> Does this problem still appear? <Y:110, N:Exit>

<110> Replace the developing unit.

<112> Exit.

Troubleshooting Procedure

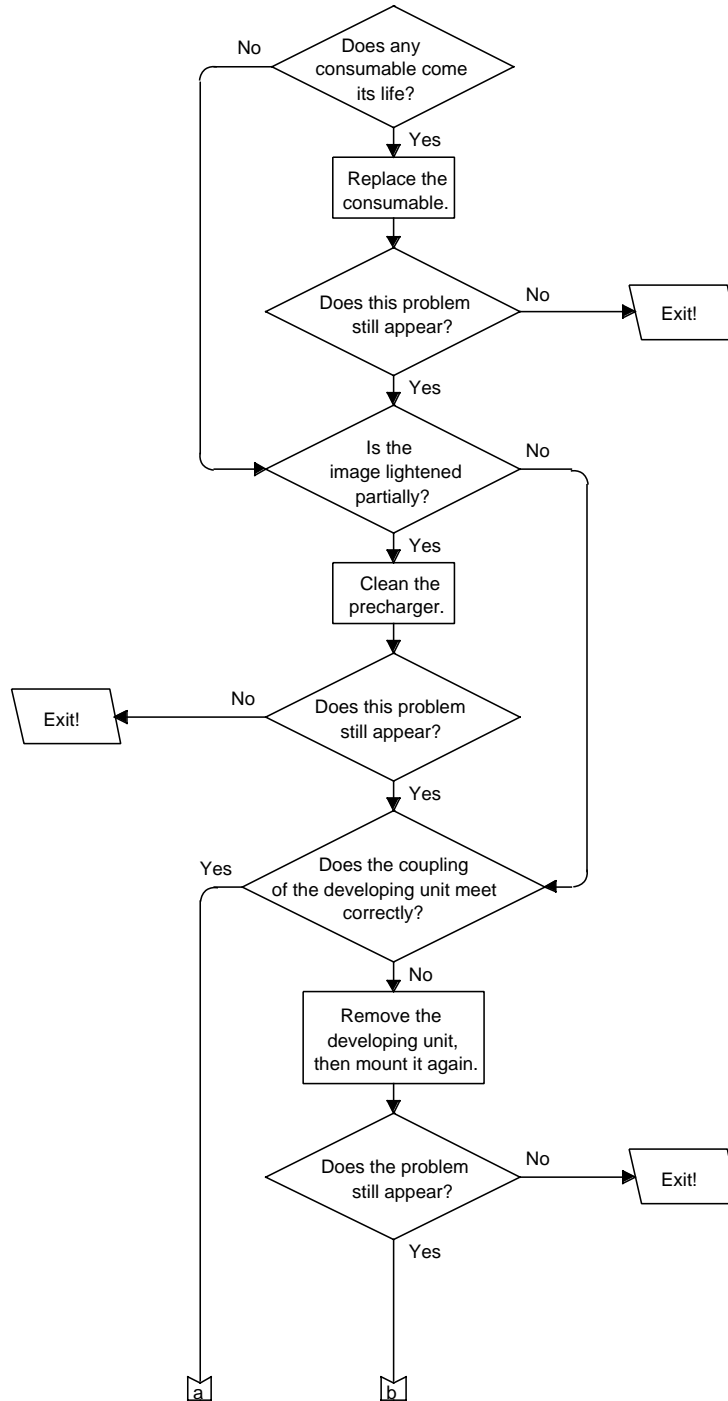

Figure 5-7. Light Print With Background Flow Chart (1 of 2)

Figure 5-7. Light Print With Background Flow Chart (2 of 2)

5-6.1. Light Horizontal Bands Print

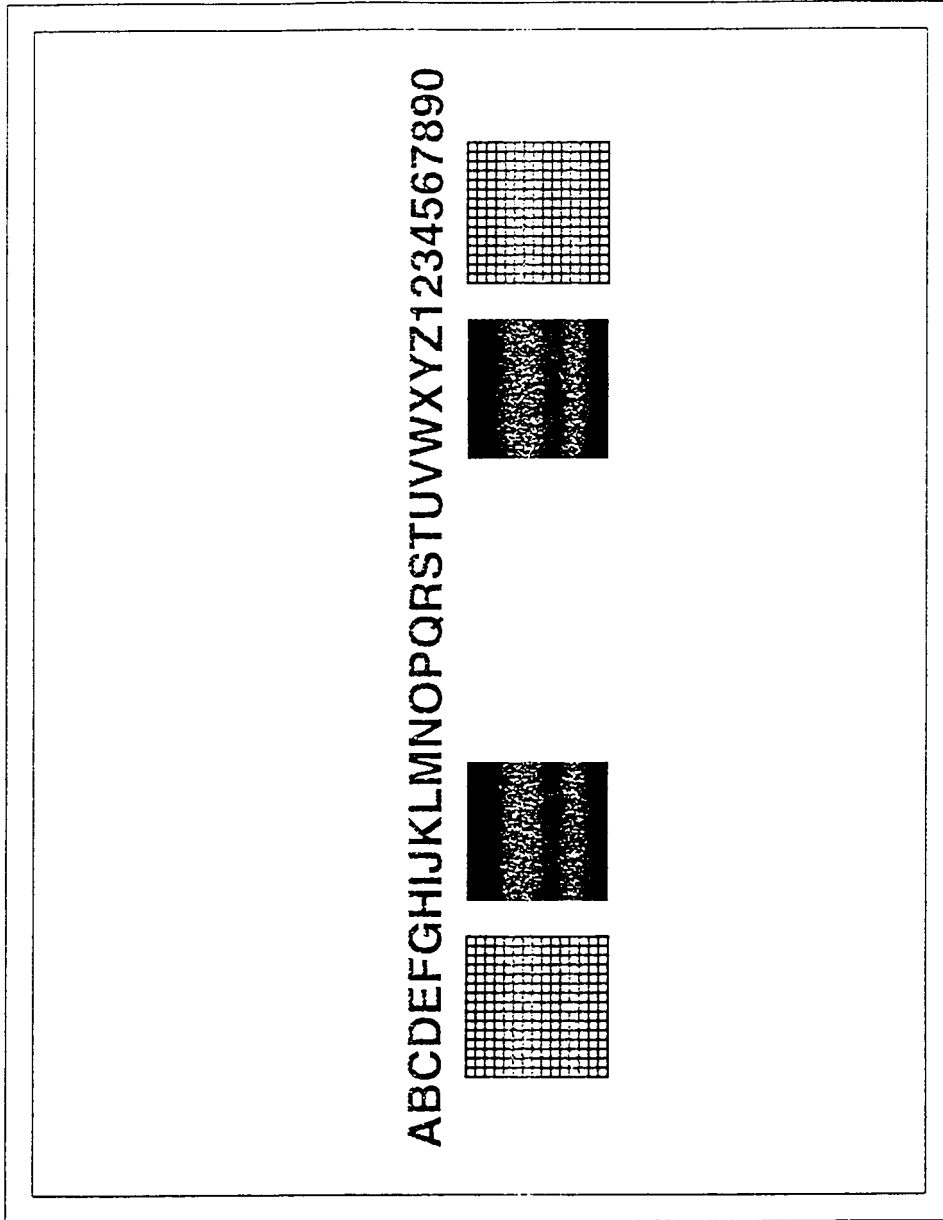

Figure 5-8. Light Horizontal Bands Print Example

Troubleshooting Procedure

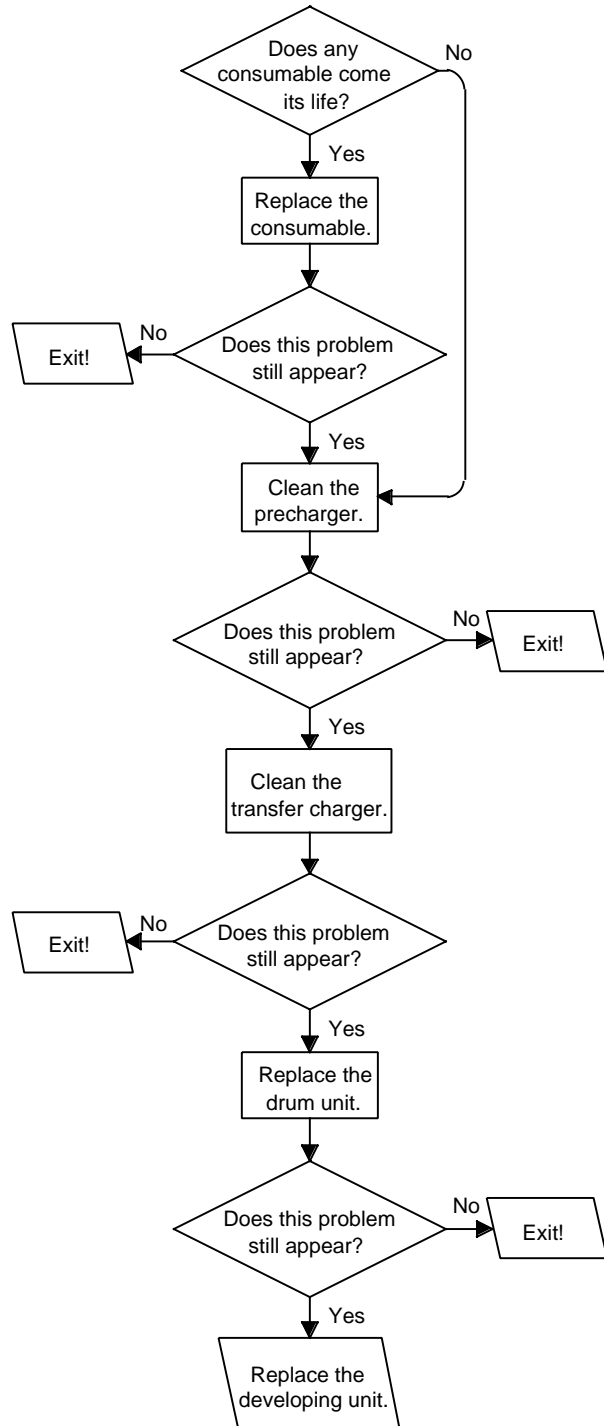

Figure 5-9. Light Horizontal Bands Print Flow Chart

5-6.1. Light Vertical Streaks Print

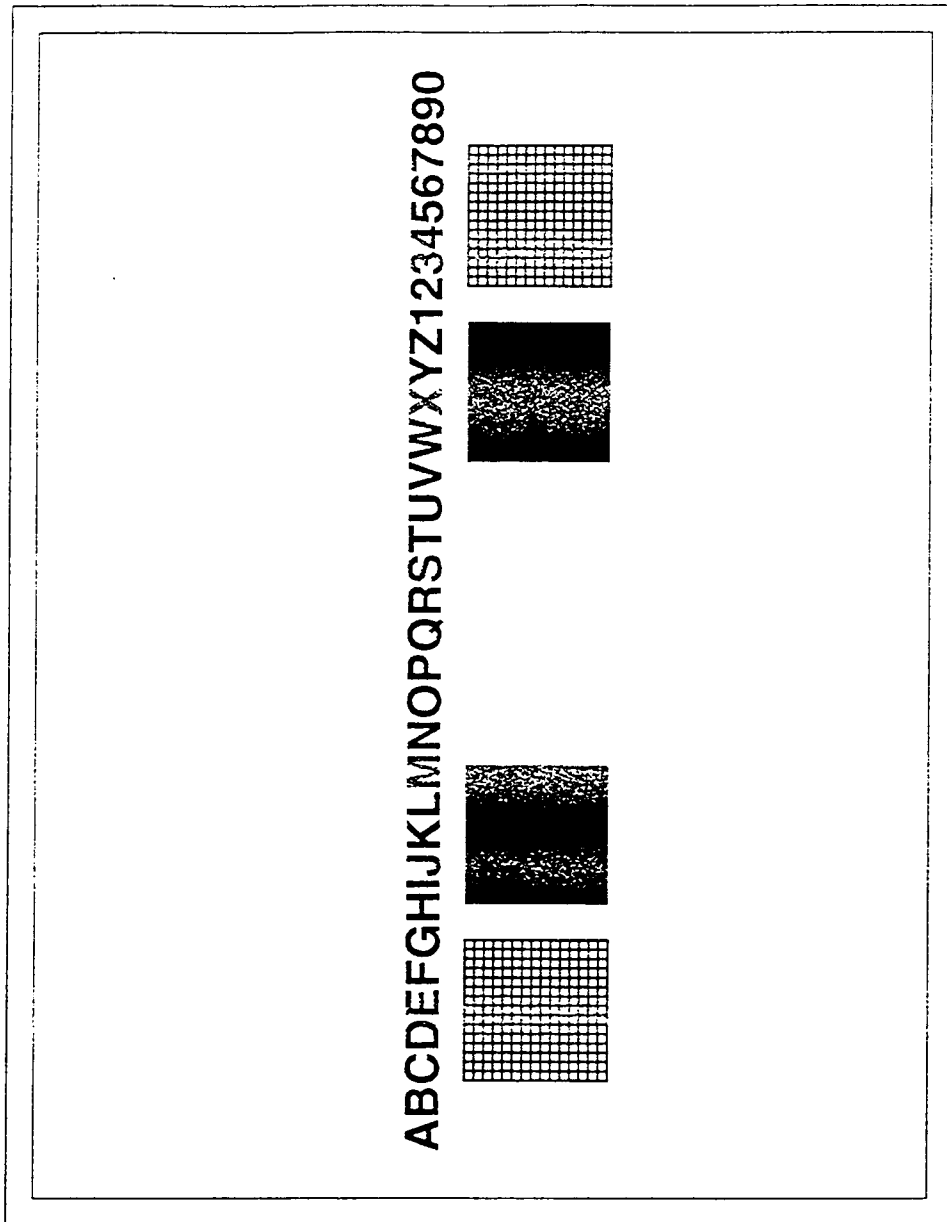

Figure 5-10. Light Vertical Streaks Print Example

Troubleshooting Procedure

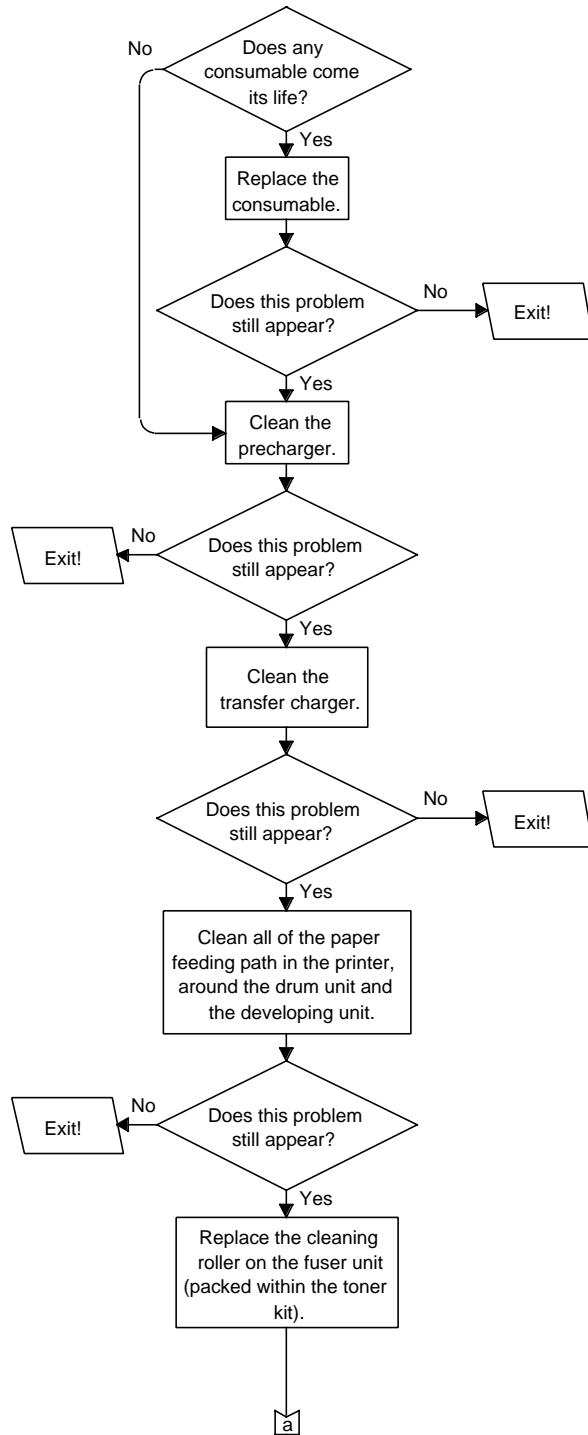

Figure 5-11. Light Vertical Streaks Print Flow Chart (1 of 2)

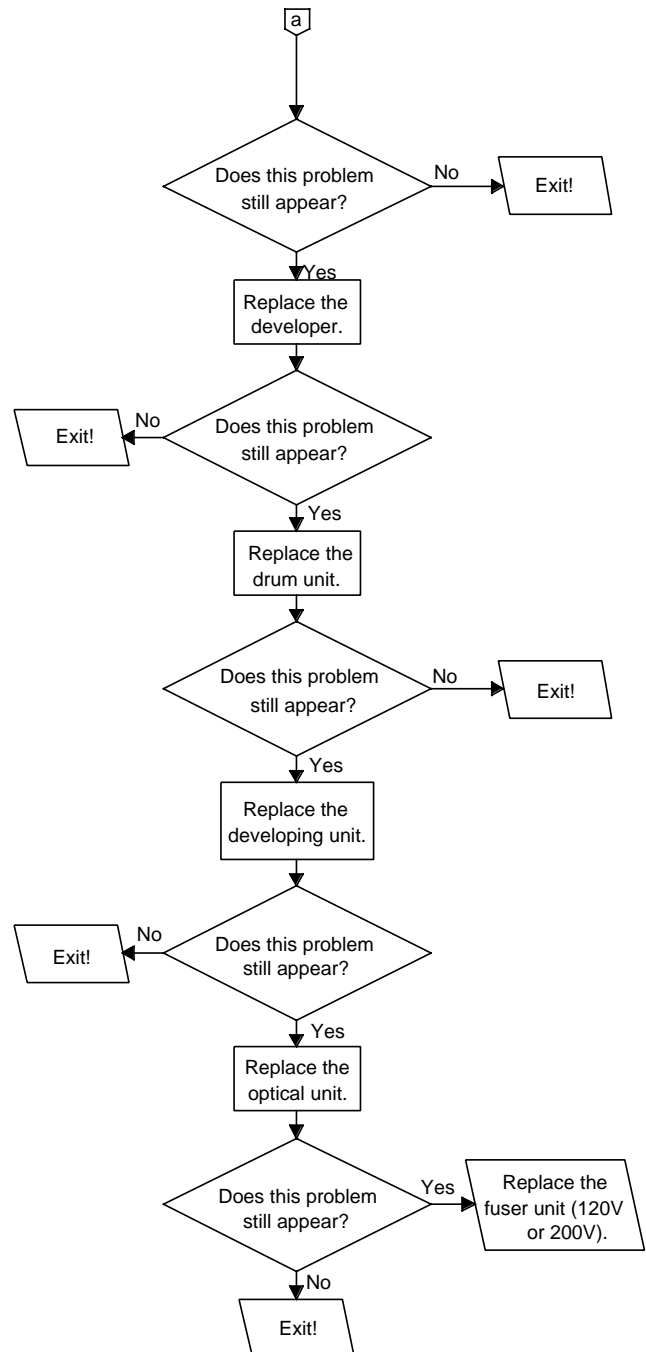

Figure 5-11. Light Vertical Streaks Print Flow Chart (2 of 2)

5-6.1. Misregistration Print

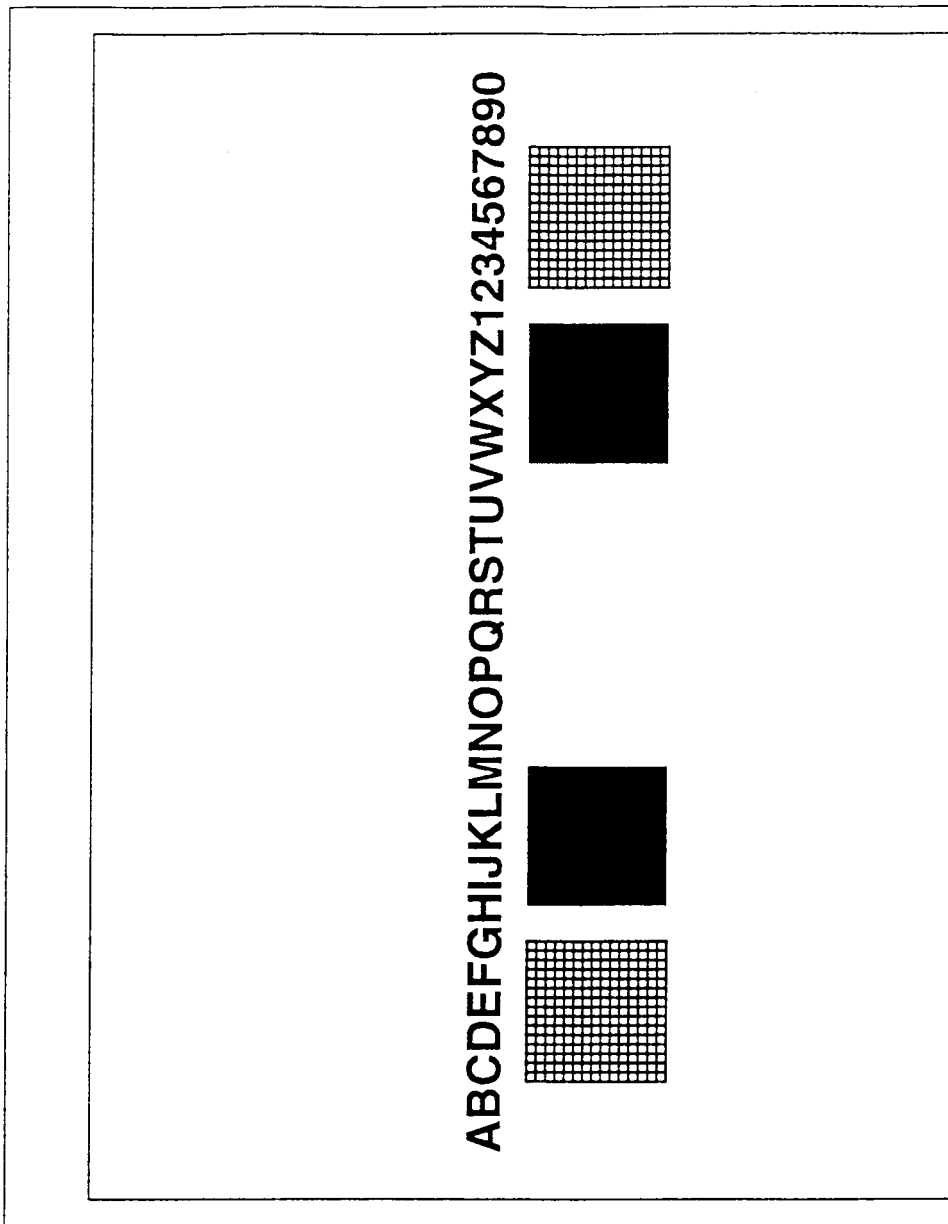

Figure 5-12. Misregistration Print Example

Troubleshooting Procedure

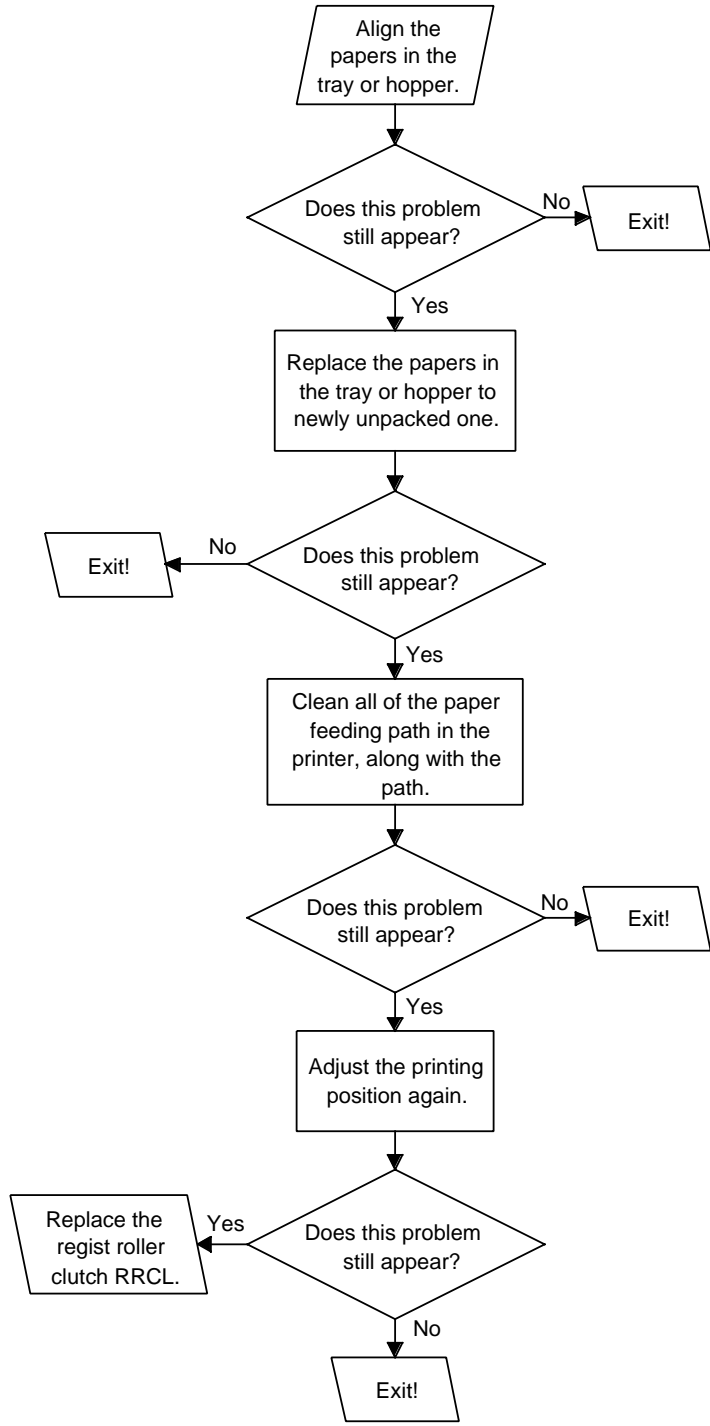

Figure 5-13. Misregistration Print Flow Chart

5-6.1. Residual Images Print

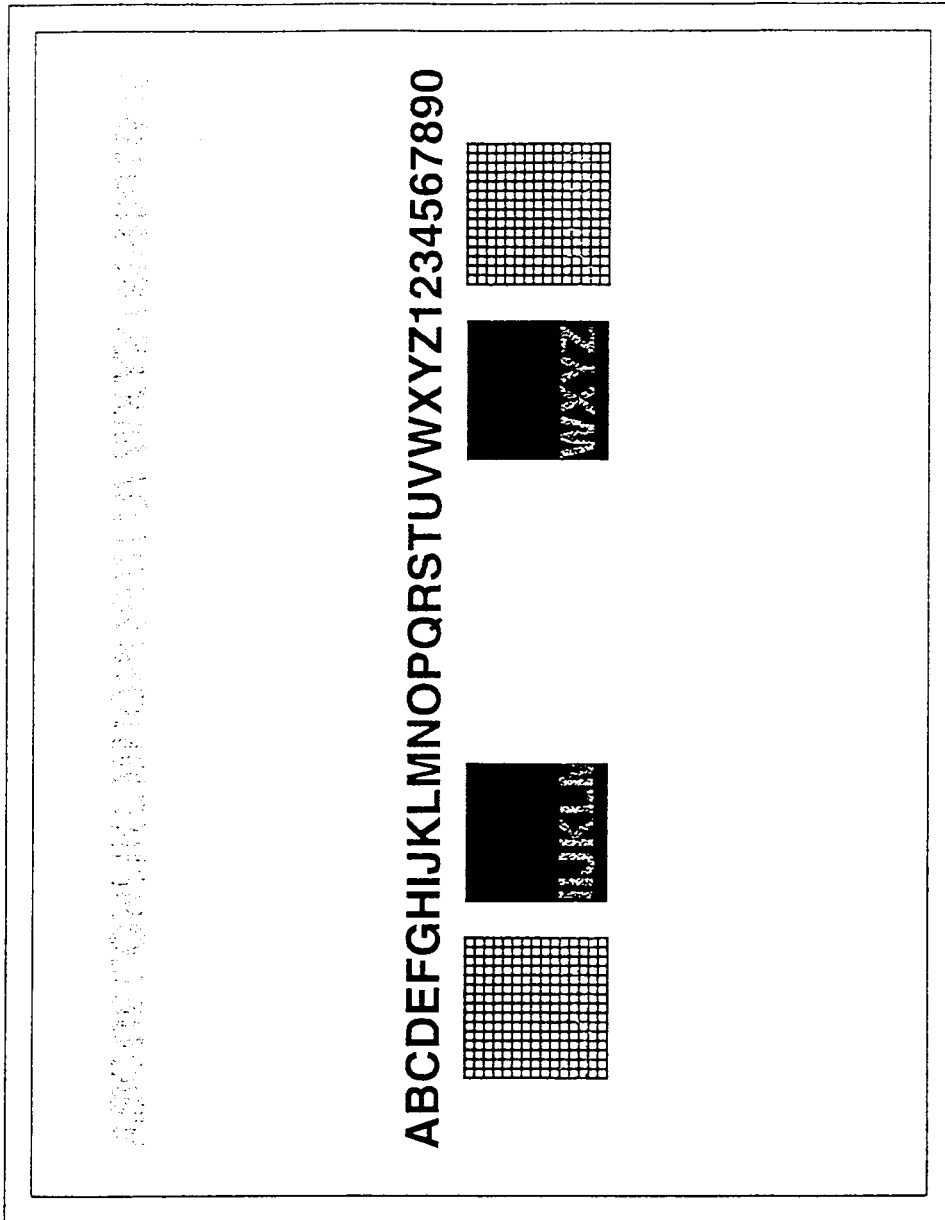

Figure 5-14. Residual Images Print Example

Troubleshooting Procedure

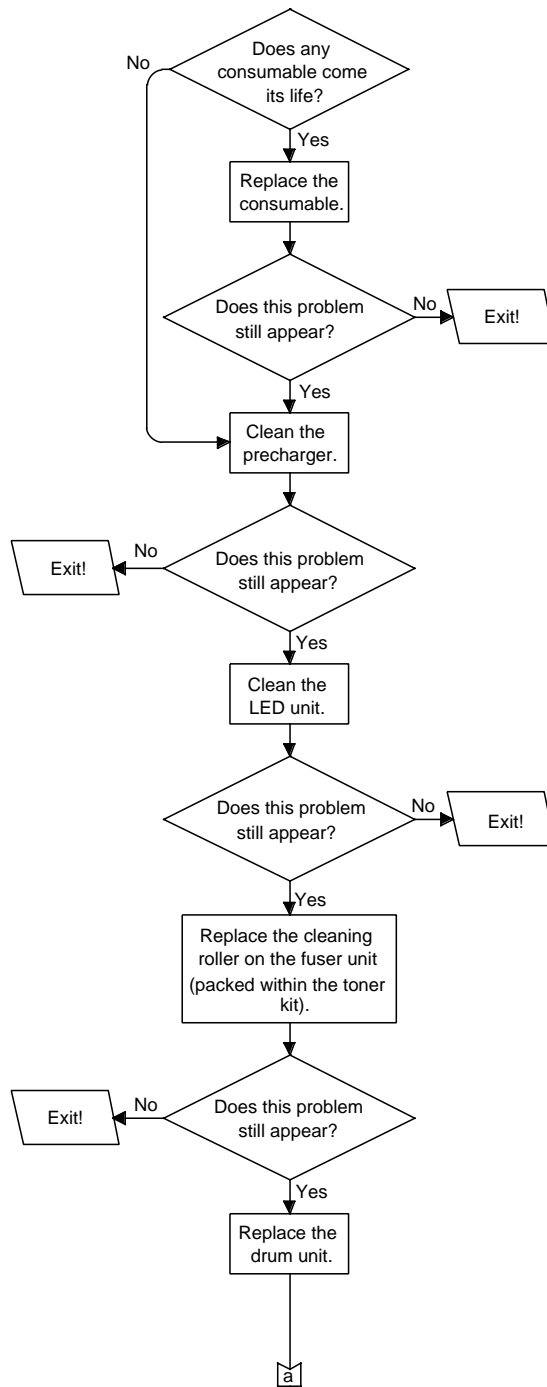

Figure 5-15. Residual Images Print Flow Chart (1 of 2)

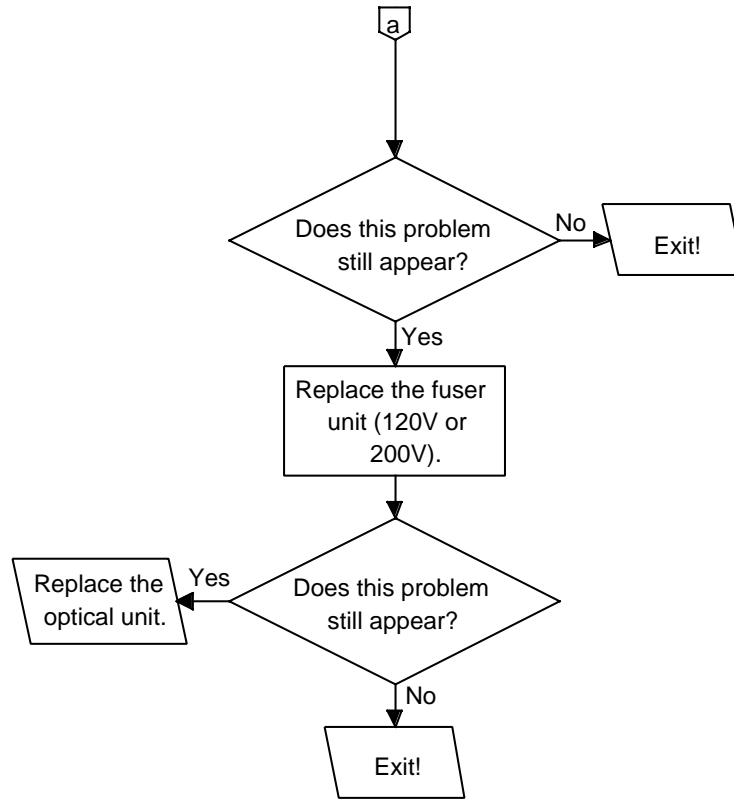

Figure 5-15. Residual Images Print Flow Chart (2 of 2)

5-6.1. Skewed Print

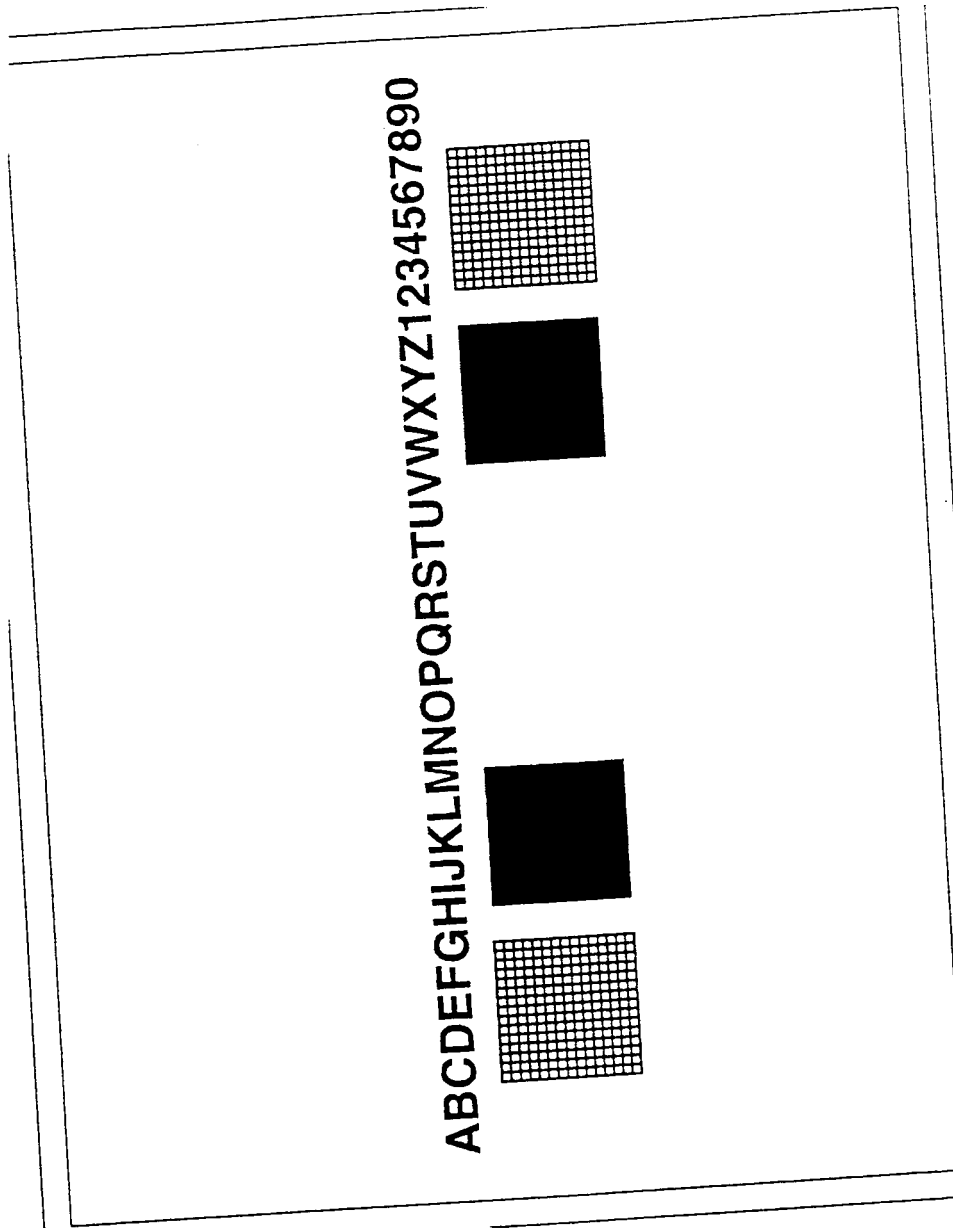

Figure 5-16. Skewed Print Example

Troubleshooting Procedure

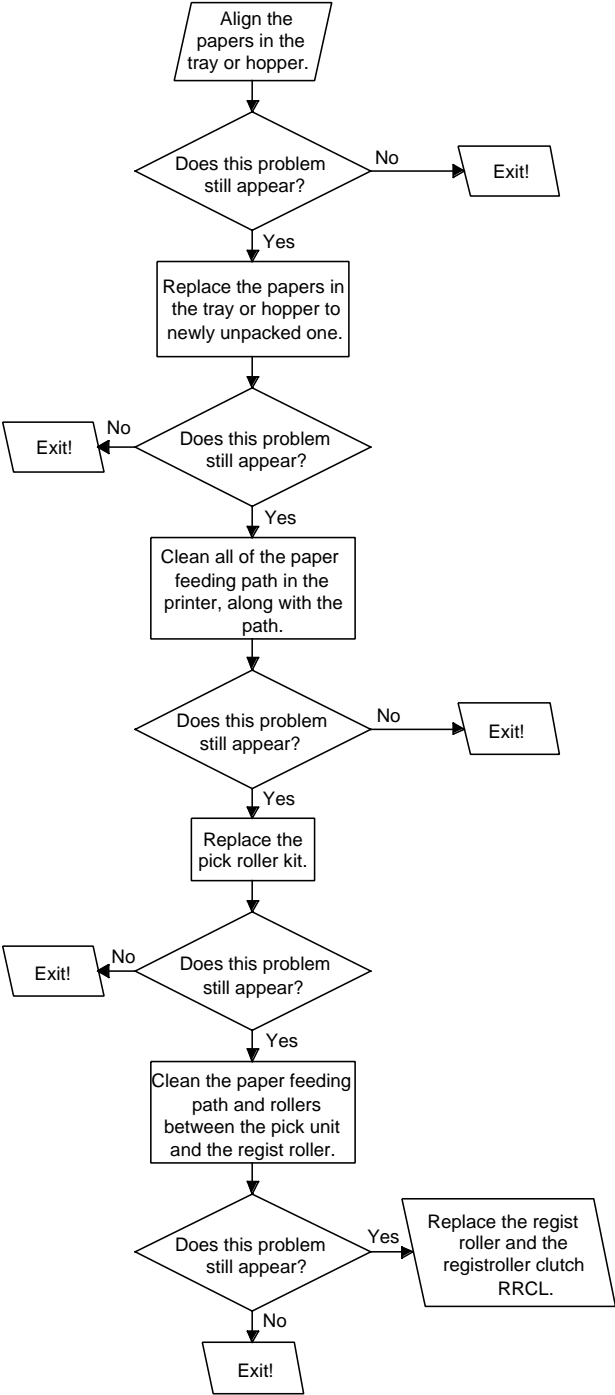

Figure 5-17. Skewed Print Flow Chart

5-6.1. Varying Print Density Print

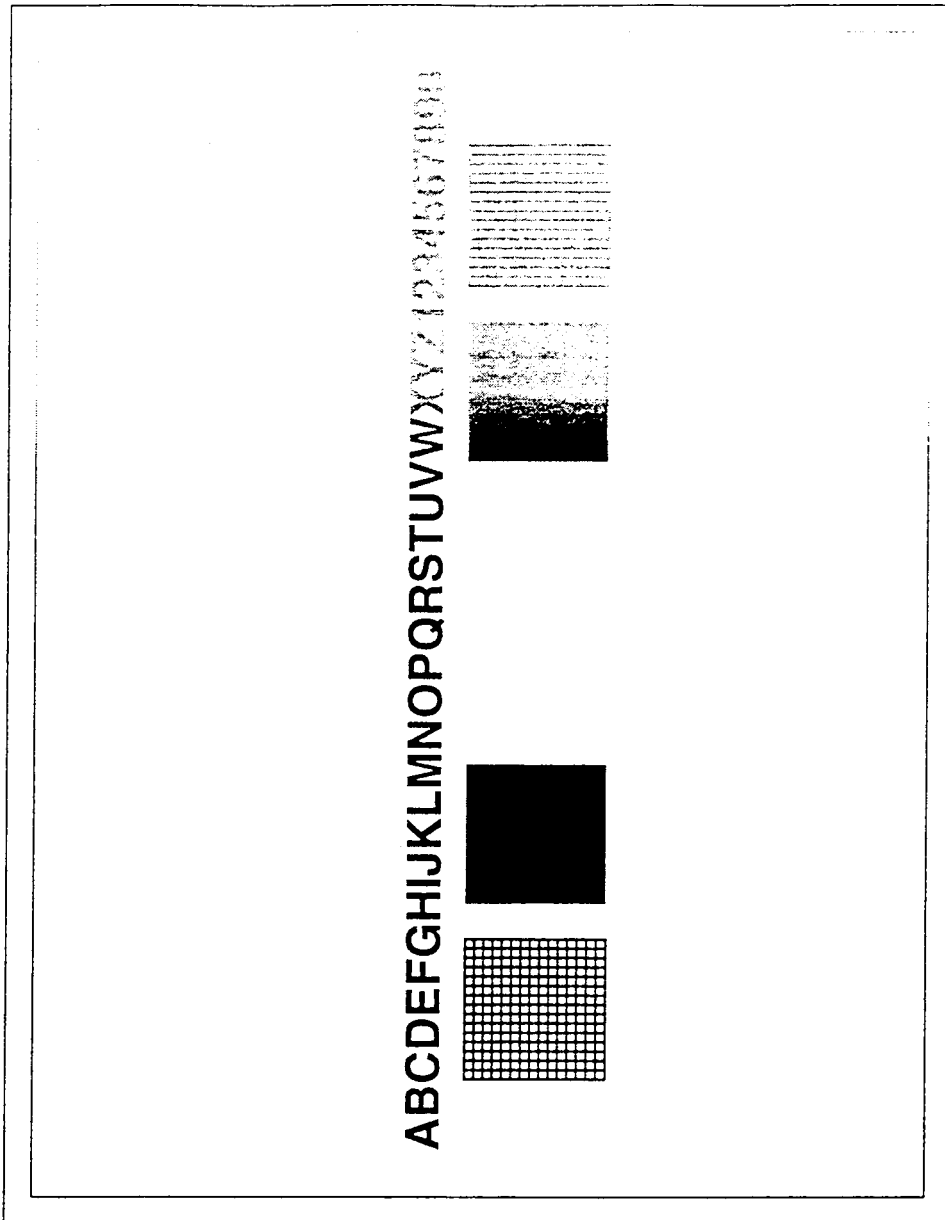

Figure 5-18. Varying Print Density Print Example

Troubleshooting Procedure

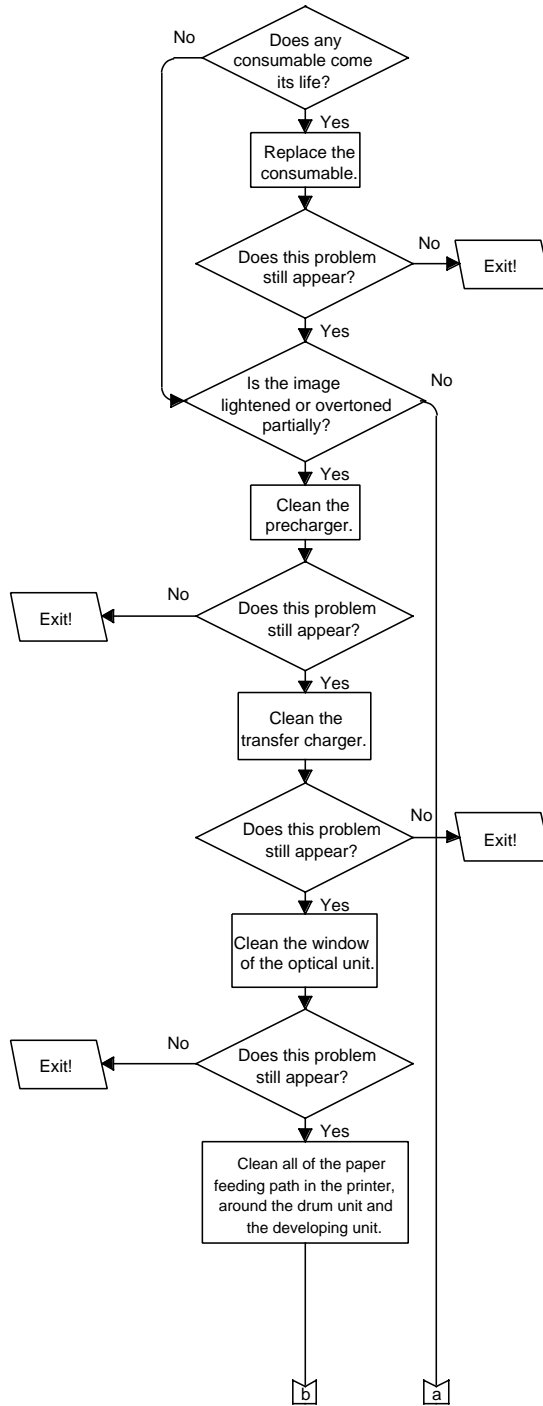

Figure 5-19. Varying Print Density Print Flow Chart (1 of 2)

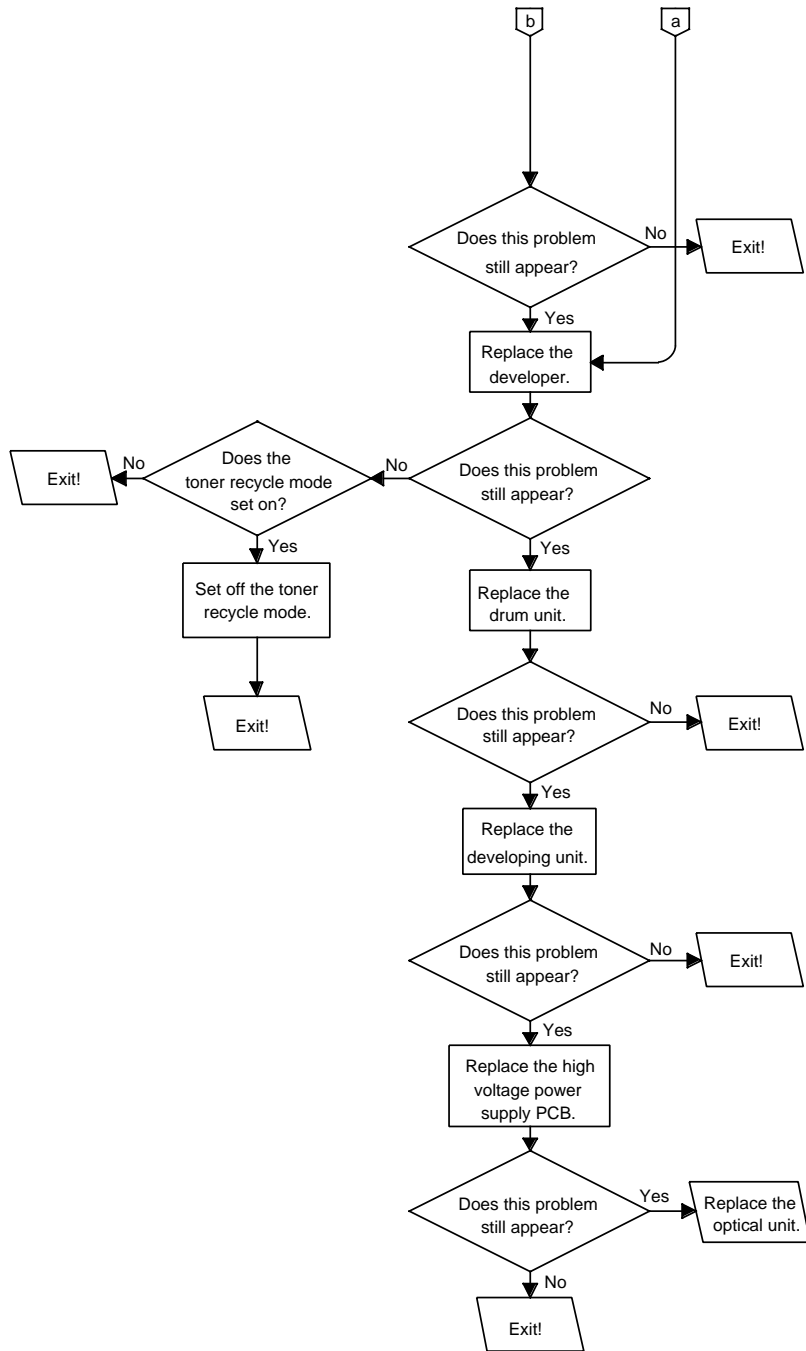

Figure 5-19. Varying Print Density Print Flow Chart (2 of 2)

5-6.1. Washed-out Print

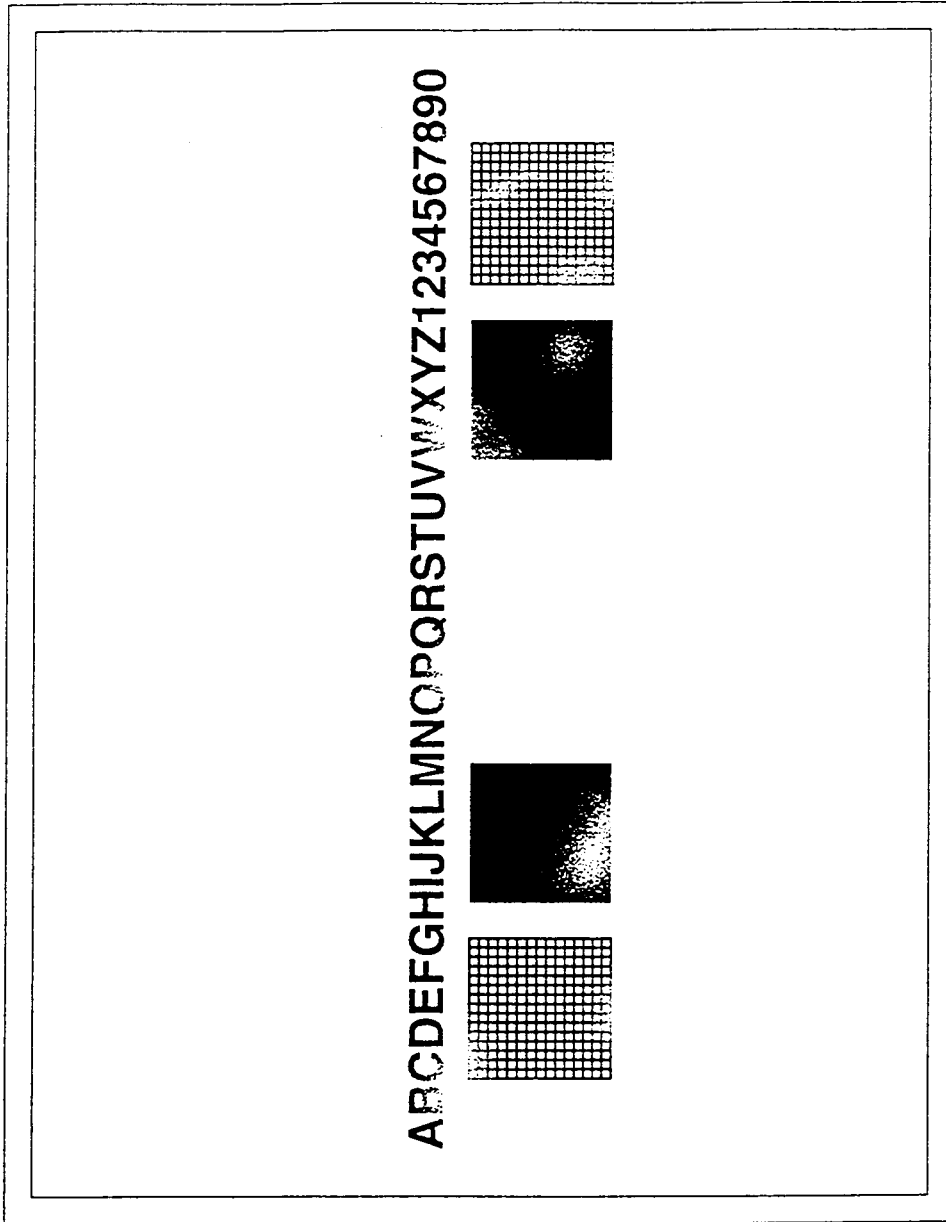

Figure 5-20. Washed-out Print Example

Troubleshooting Procedure

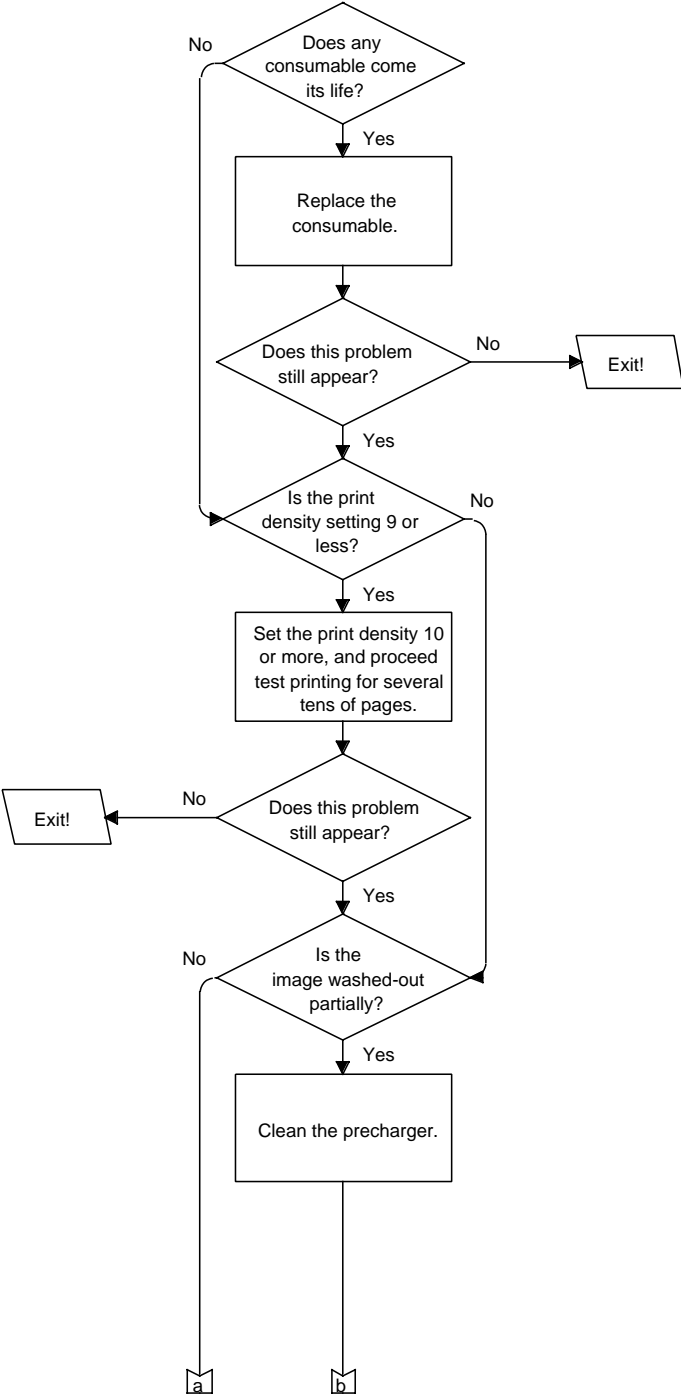

Figure 5-21. Washed-out Print Flow Chart (1 of 3)

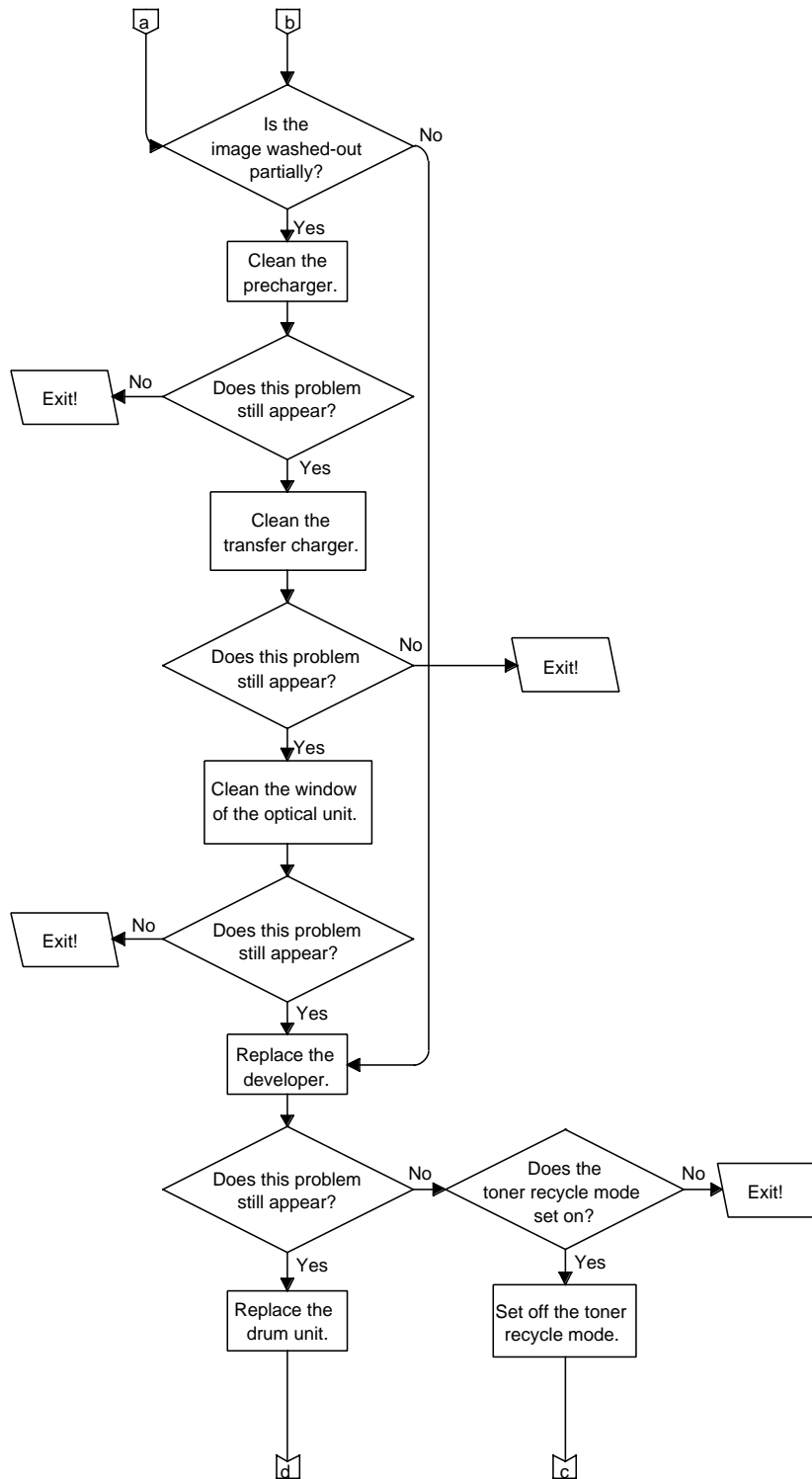

Figure 5-21. Washed-out Print Flow Chart (2 of 3)

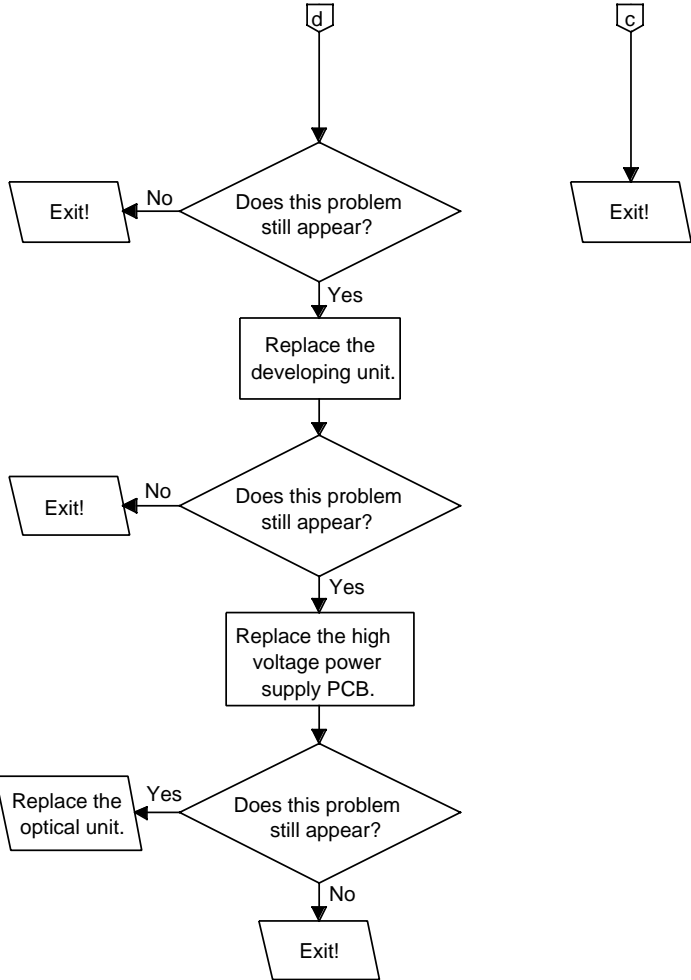

Figure 5-21. Washed-out Print Flow Chart (3 of 3)

5-7. LCH Alarm Error Message Reported Problems

As same as the paper jams in the printer, at any paper jam in the LCH occurs, check the following items before starting the trouble shoot.

- (1) Check whether the paper being used meets the standard (especially for dimensions, thickness, smoothness, foreign particles, or something sticking the paper each other).
- (2) Check whether the paper is handled correctly (especially for creases or wrinkles).
- (3) Check whether the environment both for the printer and the paper itself meets standard (especially for humidity).
- (4) Check whether the rollers and the paper guides regarding to the jam are clean (especially for scattered toner or developer, accumulated paper powder and paper pieces).

5-7.1. JAM51 LCH Pick Error

Explanation

Paper did not reach sensor KSEN before specified time passed after the pick roller started.

Troubleshooting Procedure

<010> Does the paper reached the KSEN sensor? <Y:040, N:020>

<020> Are the rollers (especially for the pick roller) or paper feeding path around the pick roller dirty?

<Y:022, N:030>

<022> Clean the rollers and guides.

<024> Does this jam still occur? <Y:030, N:Exit>

<030> Does the pick roller asy or separator roller asy come or exceed its life, or have any damage?

<Y:032, N:040>

<032> Replace the pick roller asy or the separator roller asy

<034> Does this jam still occur? <Y:040, N:Exit>

<040> Is there something clogging at the sensor KSEN (paper pieces, etc.)? <Y:042, N:050>

<042> Remove anything clogging at the sensor.

<044> Does this jam still occur? <Y:050, N:Exit>

<050> Check whether the PW board-A receives the output signal from the sensor KSEN properly. Is the voltage across pin3 of the connector CN2 on the PW board-A and GND approx 0V when the KSEN is blocked? Also, when KSEN is unblocked, does the voltage change to approx 5V?

<Y:060, N:052>

<052> Check damages or pinches of wire, cable and connector between the following connectors:
CN2 on the PW board-A and the sensor KSEN.

<053> Does this jam still occur? <Y:054, N:Exit>

<054> Replace the sensor KSEN.

<055> Does this jam still occur? <Y:100, N:Exit>

<060> Check damages or pinches of wire, cable, and connector between the following connectors:
CN4 on the PW board-A and the motor KMOT,

CN3 on the power supply PCB of the printer and the LCH interface connector,

LCH interface connector and CN1 on the PW board-A.

<062> Does this jam still occur? <Y:070, N:Exit>

<070> Remove the paper feed motor KMOT. Can the motor be turned by hand? <Y:080, N:090>

<080> Turn the pick roller counter-clockwise by hand while the motor KMOT being removed. Is the pulley G1 turning? <Y:090, N:082>

<082> Roller driving system is unrepairably damaged. Replace the whole LCH.

<084> Exit.

<090> Replace the motor KMOT.

<092> Does this jam still occur? <Y:100, N:Exit>

<100> Replace the PW board-A.

Troubleshooting Procedure

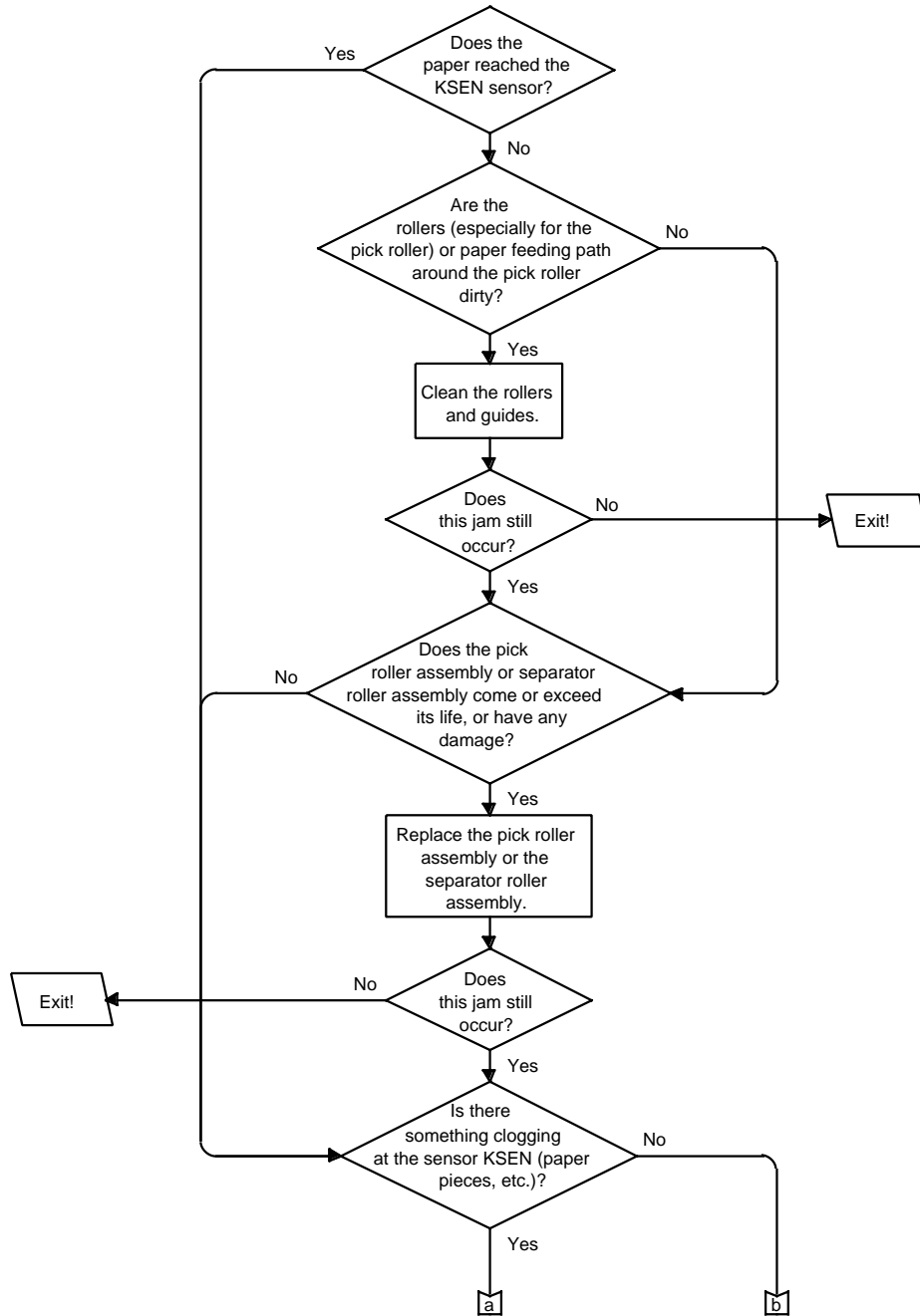
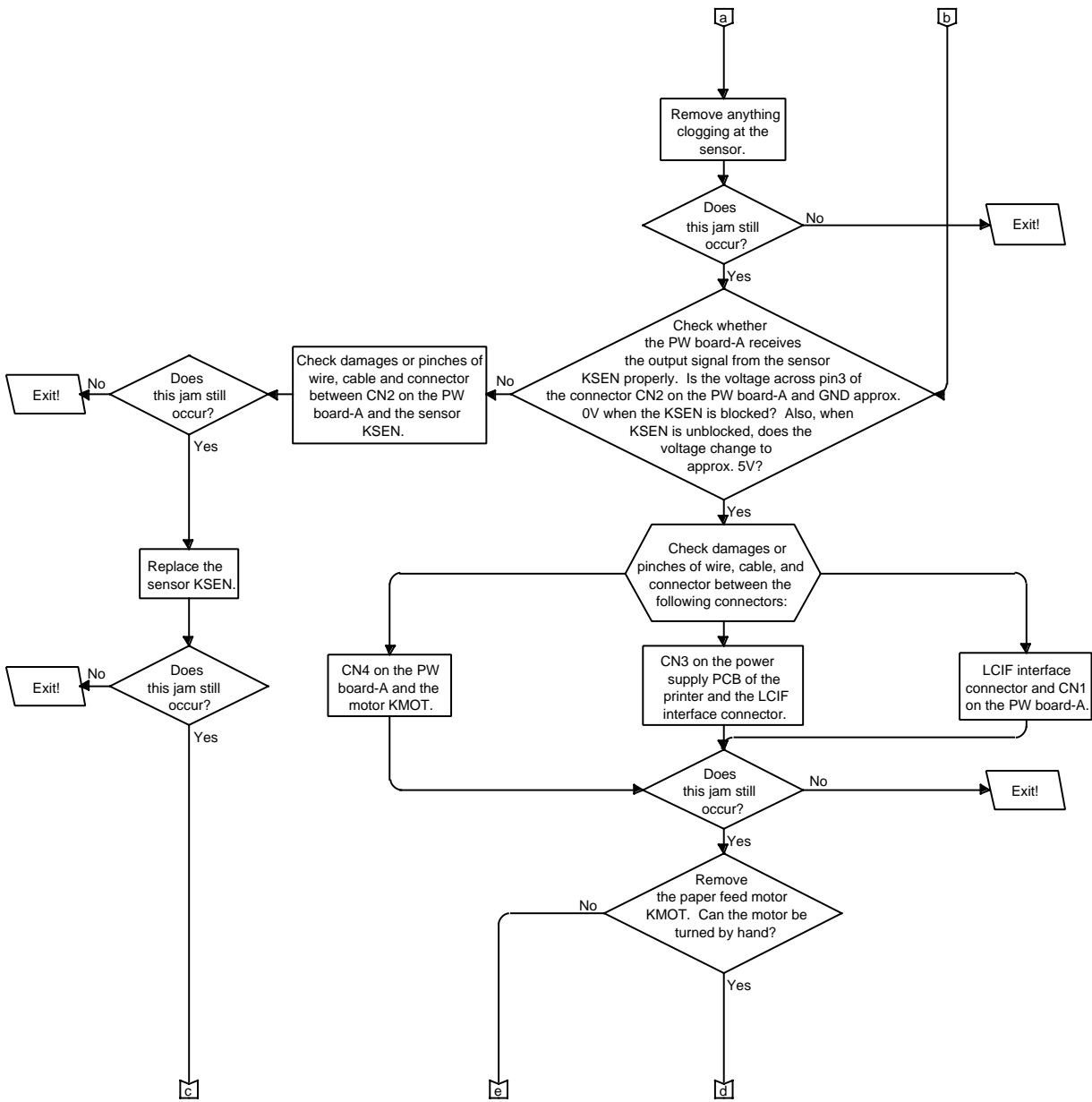

Figure 5-22. JAM51 LCH Pick Error Flow Chart (1 of 3)



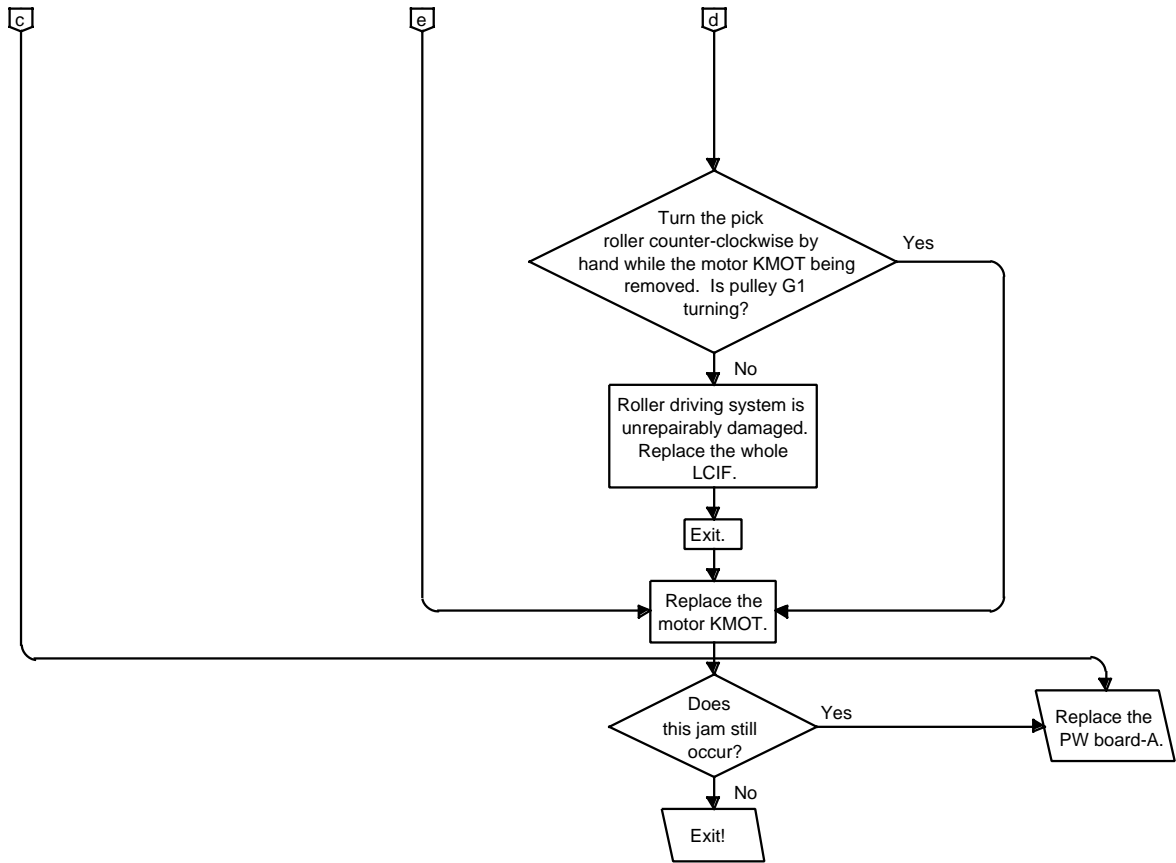

Figure 5-2. JAM51 LCH Pick Error Flow Chart (3 of 3)

Reference Diagrams

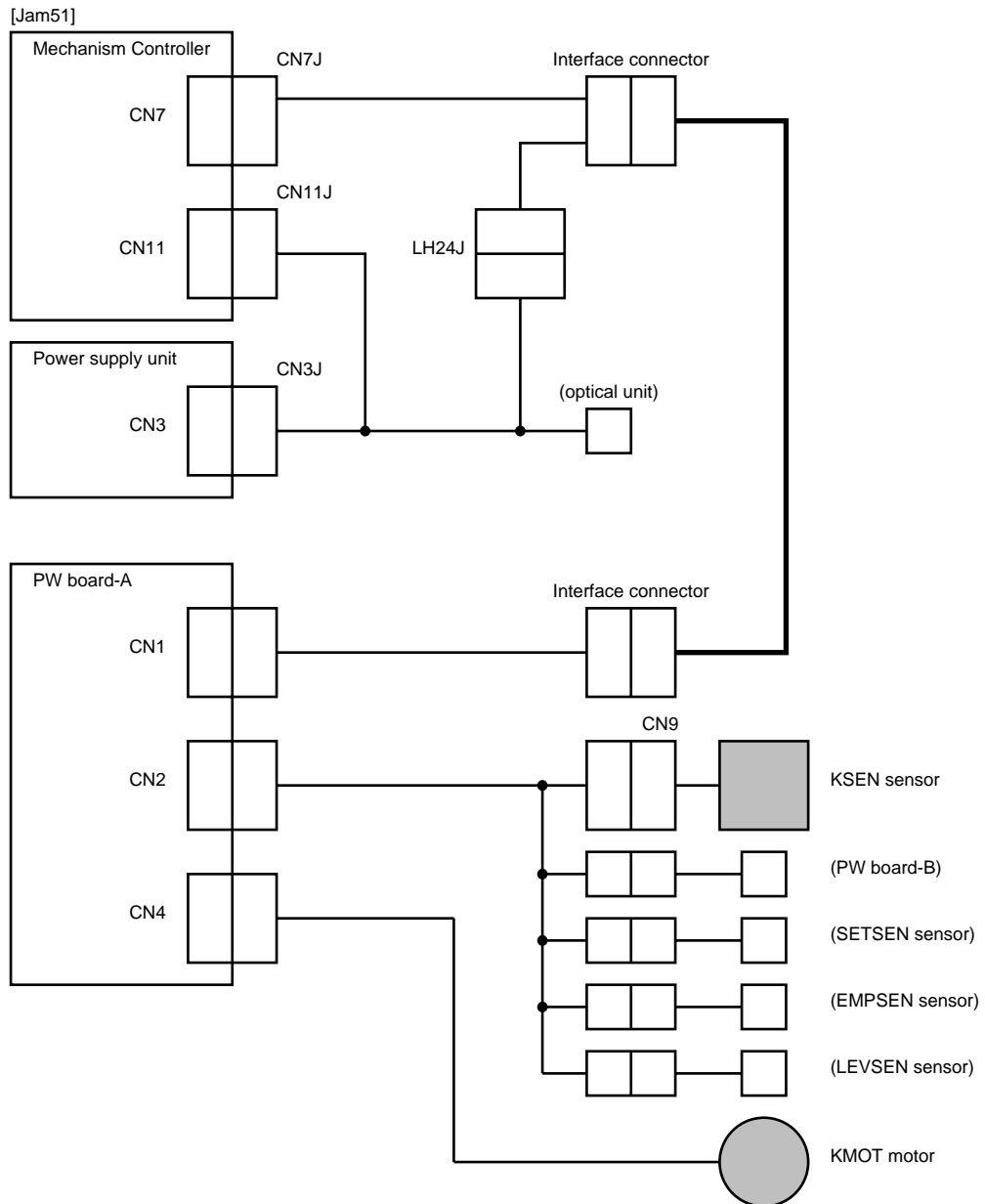

Figure 5-3. LCH Pick Error (JAM51) Interconnections Diagram (1 of 2)

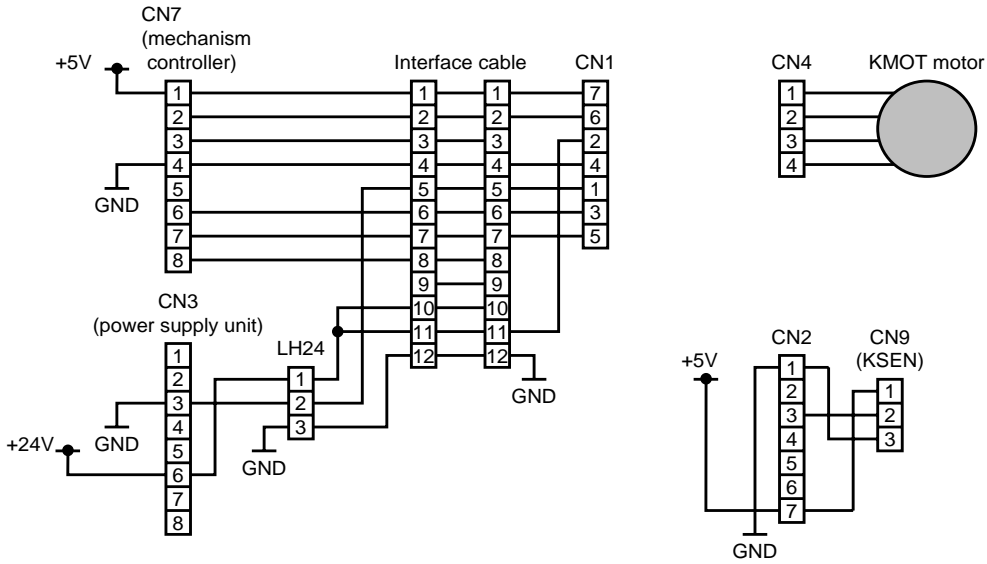

Figure 5-3. LCH Pick Error (JAM51) Interconnections Diagram (2 of 2)

5-7.2. JAM52 LCH Feed Jam 1**Explanation**

Once the paper feed motor (KMOT) was stopped and was turned on again. Paper did not reach KSEN sensor specified time passed after the KMOT was turned on.

Troubleshooting Procedure

<010> Does the paper reached the KSEN sensor? <Y:040, N:020>

<020> Are the rollers (especially for the pick roller) or paper feeding path around the pick roller dirty? <Y:022, N:030>

<022> Clean the rollers and guides.

<024> Does this jam still occur? <Y:030, N:Exit>

<030> Does the pick roller asy or separator roller asy come or exceed its life, or have any damage? <Y:032, N:040>

<032> Replace the pick roller asy or the separator roller asy.

<034> Does this jam still occur? <Y:040, N:Exit>

<040> Is there something clogging at the sensor KSEN (paper pieces, etc.)? <Y:042, N:050>

<042> Remove anything clogging at the sensor.

<044> Does this jam still occur? <Y:050, N:Exit>

<050> Check whether the PW board-A receives the output signal from the sensor KSEN properly. Is the voltage across pin3 of the connector CN2 on the PW board-A and GND approx 0V when the KSEN is blocked? Also, when KSEN is unblocked, does the voltage change to approx 5V? <Y:060, N:052>

<052> Check damages or pinches of wire, cable and connector between the following connectors:

CN2 on the PW board-A and the sensor KSEN.

<053> Does this jam still occur? <Y:054, N:Exit>

<054> Replace the sensor KSEN.

<055> Does this jam still occur? <Y:100, N:Exit>

<060> Check damages or pinches of wire, cable, and connector between the following connectors:

CN4 on the PW board-A and the motor KMOT,

CN3 on the power supply PCB of the printer and the LCH interface connector,

LCH interface connector and CN1 on the PW board-A.

<062> Does this jam still occur? <Y:070, N:Exit>

<070> Remove the paper feed motor KMOT. Can the motor be turned by hand? <Y:080, N:090>

<074> Does this jam still occur? <Y:080, N:Exit>

<080> Turn the pick roller counter-clockwise by hand while the motor KMOT being removed. Is the pulley G1 turning? <Y:090, N:082>

<082> Roller driving system is unrepairably damaged. Replace the whole LCH.

<084> Exit.

<090> Replace the motor KMOT (CA81003-5654, see x-xx, fig.2-20).

<092> Does this jam still occur? <Y:100, N:Exit>

<100> Replace the PW board-A (CA81003-5656, see x-xx, fig.2-16).

Troubleshooting Procedure

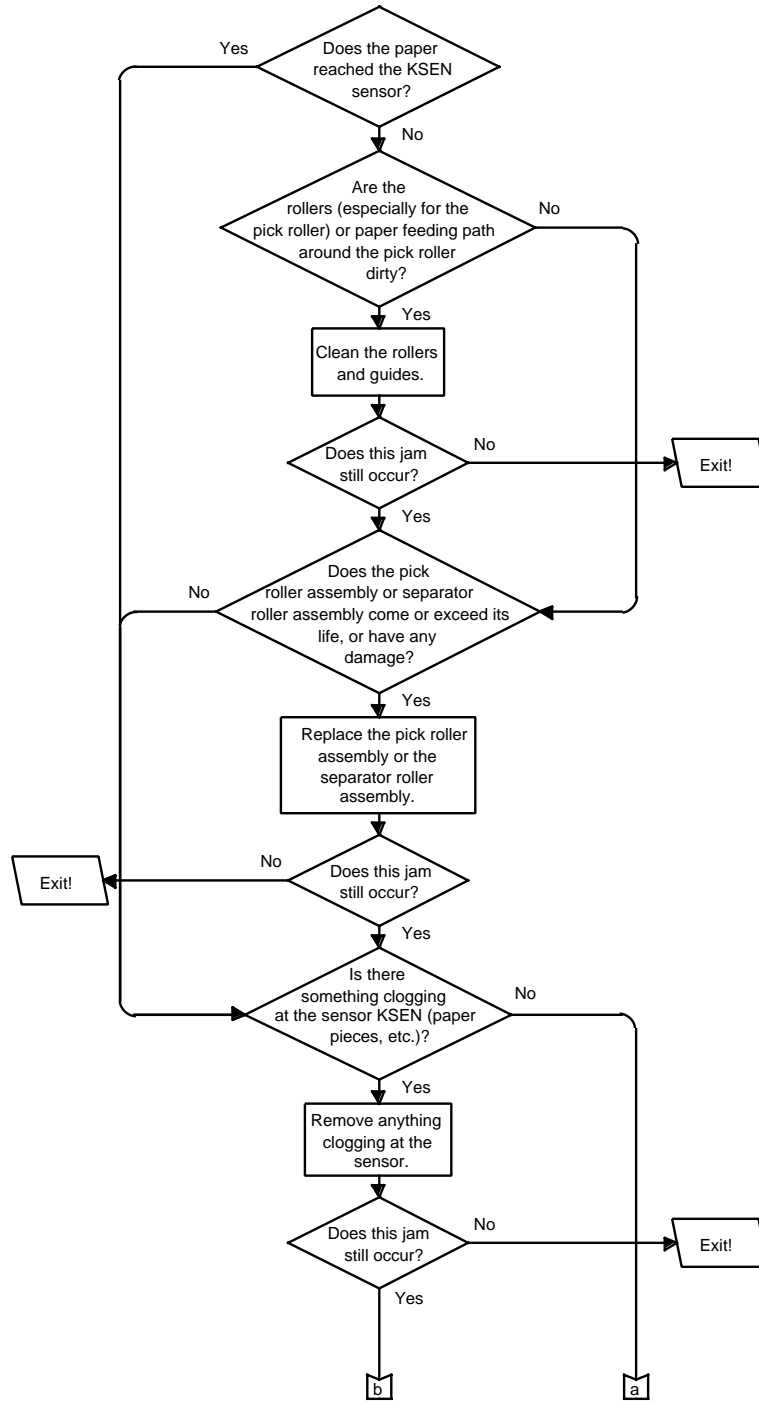

Figure 5-4. JAM52 LCH Feed Jam 1 Flow Chart (1 of 2)

Reference Diagrams

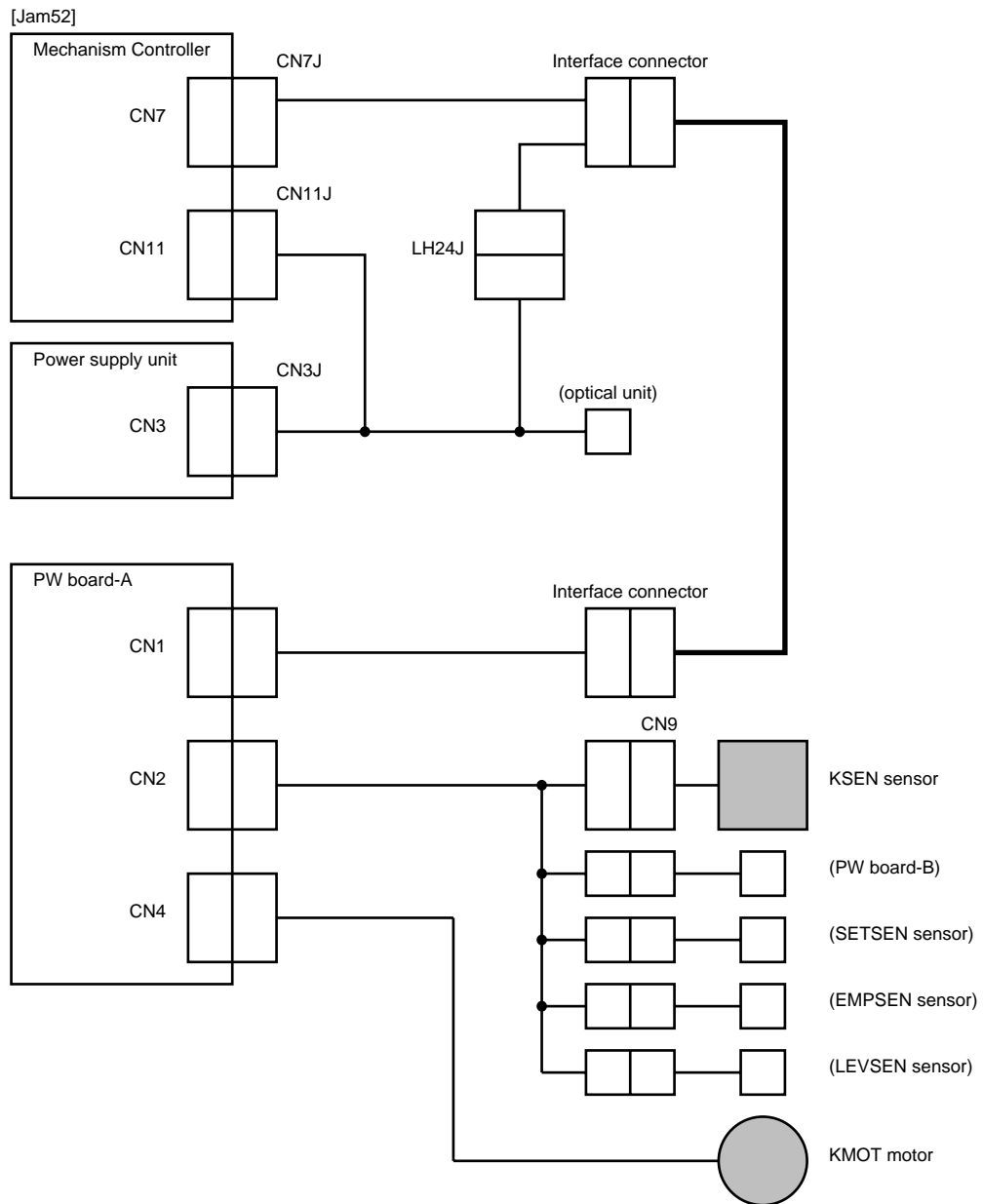

Figure 5-5. LCH Feed Jam 1 (JAM52) Interconnections Diagram (1 of 2)

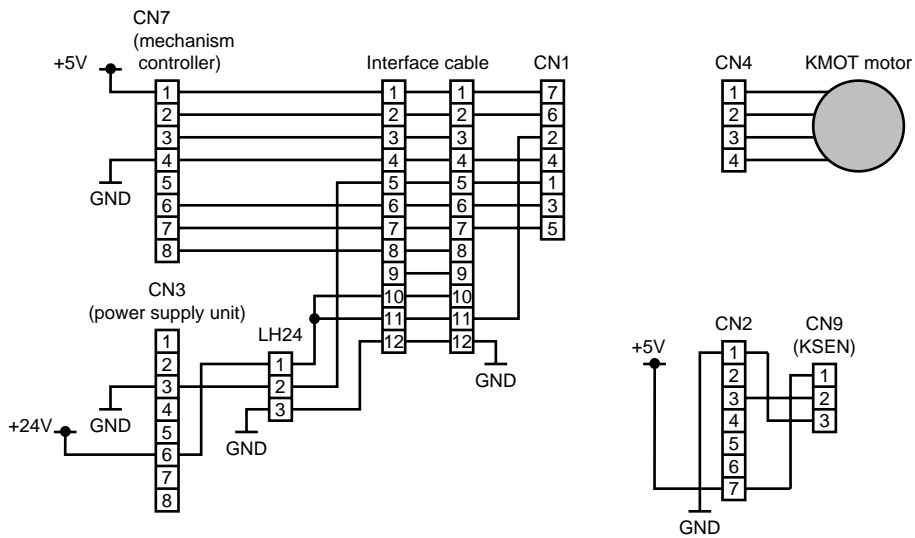

Figure 5-5. LCH Feed Jam 1 (JAM52) Interconnections Diagram (2 of 2)

5-7.3. JAM53 LCH Feed Jam 2

Explanation

When the printer is reset, there is paper at KSEN sensor.

Troubleshooting Procedure

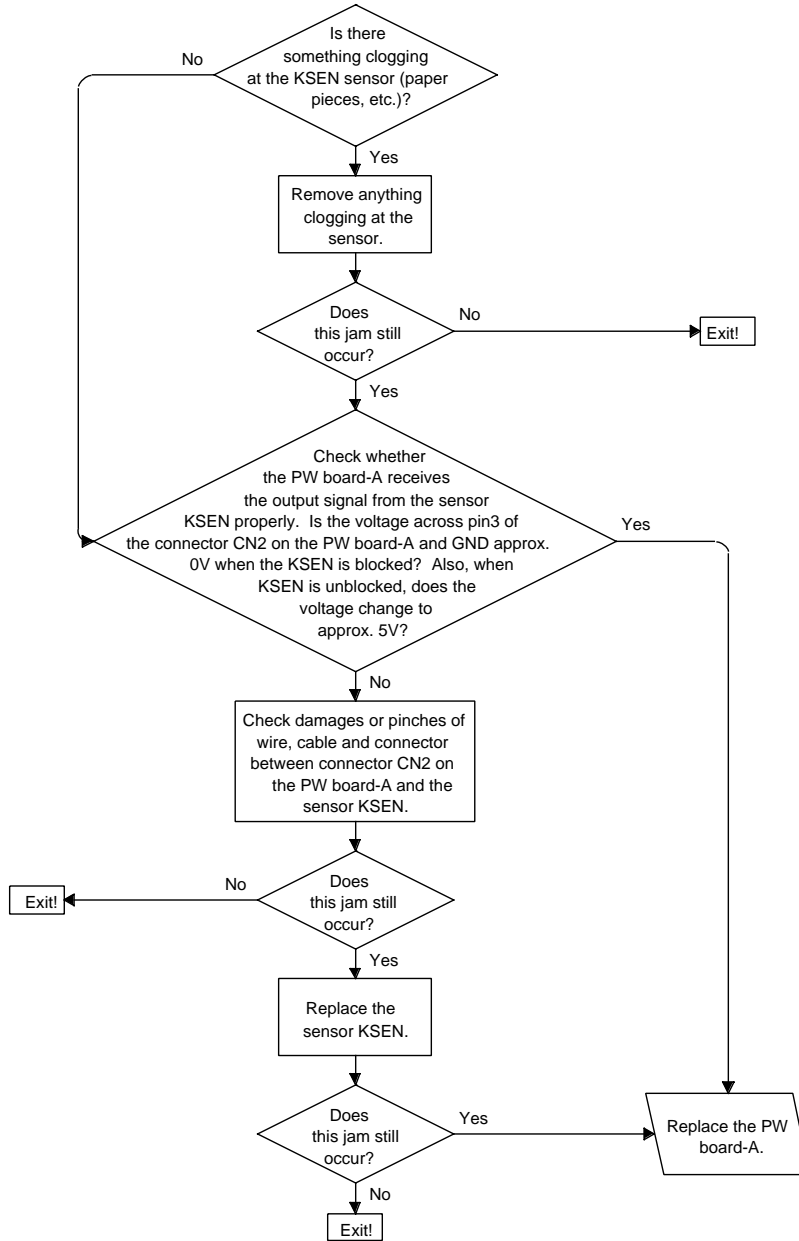

Figure 5-6. JAM53 LCH Feed Jam 2 Flow Chart

Reference Diagrams

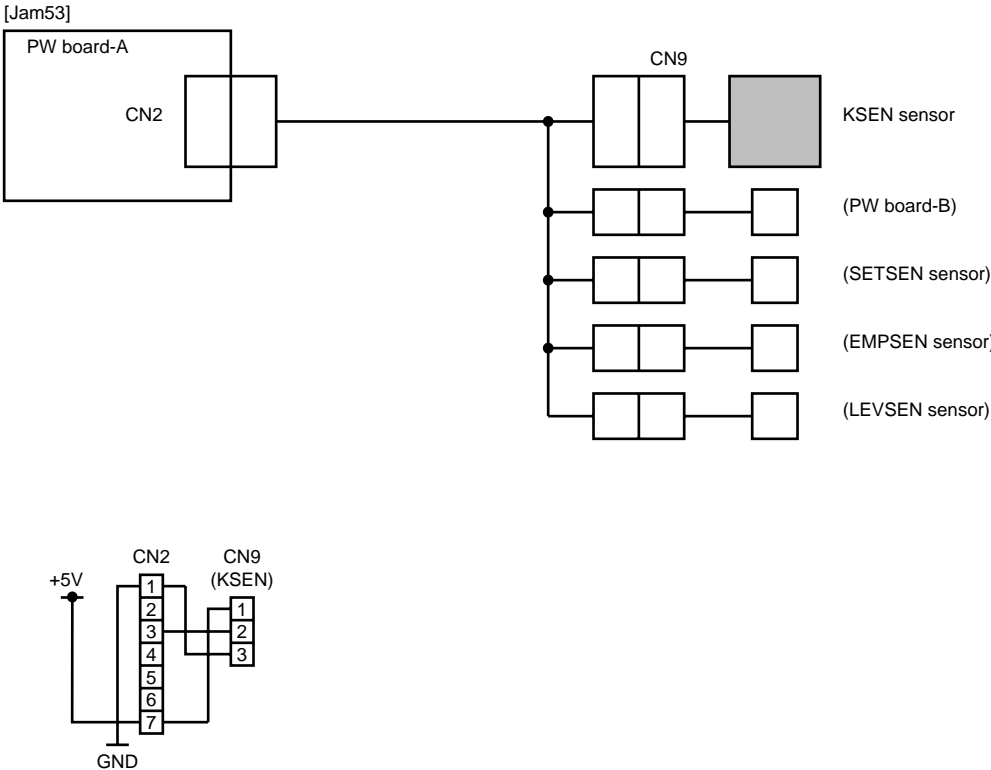

Figure 5-7. LCH Feed Jam 2 (JAM53) Interconnections Diagram

5-7.4. SVCC4 LCH Elevator Descent Alarm**Explanation**

The paper table lowered position sensor (LOWSEN) is not blocked (the sensor output does not go low) 12 sec. after the elevator motor (HMOT) is energized.

Troubleshooting Procedure

Troubleshooting Procedure

- <010> Is the actuator stopped and clogged into the sprocket? <Y:012, N:020>
- <012> The table driving system may already be unreparably deformed. Replace the whole LCH.
- <014> Exit.
- <020> Is there something clogging at the sensor LOWSEN (paper pieces, etc.)? <Y:022, N:030>
- <022> Remove anything clogging at the sensor.
- <024> Does this alarm still occur? (Confirm the front door of the printer is closed, then open and close the cassette door of the LCH.) <Y:030, N:Exit>
- <030> Check whether the PW board-A receives the output signal from the sensor LOWSEN properly. Is the voltage across pin5 of the connector CN3 on the PW board-A and GND approx 0V when the LOWSEN is blocked? Also, when LOWSEN is unblocked, does the voltage change to approx 5V? <Y:040, N:032>
- <032> Check damages or pinches of wire, cable and connector between the following connectors:
CN3 on the PW board-A and the sensor LOWSEN.
- <033> Does this jam still occur? <Y:034, N:Exit>
- <034> Replace the sensor LOWSEN (CA81003-5653, see x-xx, fig.2-14).
- <035> Does this jam still occur? <Y:040, N:Exit>
- <040> After resetting the malfunction, does opening/closing the cassette door of the LCH cause the paper table to ascend? (Confirm the front door of the printer is closed.) <Y:050, N:060>
- <050> Replace the PW board-A.
- <052> Exit.
- <060> Check damages or pinches of wire, cable, and connector between the following connectors:
CN3 on the PW board-A and the sensor DSEN,
CN5 on the PW board-A and the motor HMOT,

CN3 on the power supply PCB of the printer and the LCH interface connector,
LCH interface connector and CN1 on the PW board-A.

<062> Does this jam still occur? <Y:070, N:Exit>

<070> Replace the sensor DSEN.

<072> Does this jam still occur? <Y:080, N:Exit>

<080> Does opening/closing the cassette door of the LCH cause the motor HMOT to be applied 24V? (Confirm the front door of the printer is closed.) <Y:050, N:090>

<090> Remove the elevator motor HMOT (refer x-xx), then open/close the cassette door of LCH.

Does the motor rotate? <Y:012, N:100>

<100> Replace the motor HMOT (CA81003-5655, see x-xxx, fig.3-16).

<102> Exit.

Reference Diagrams

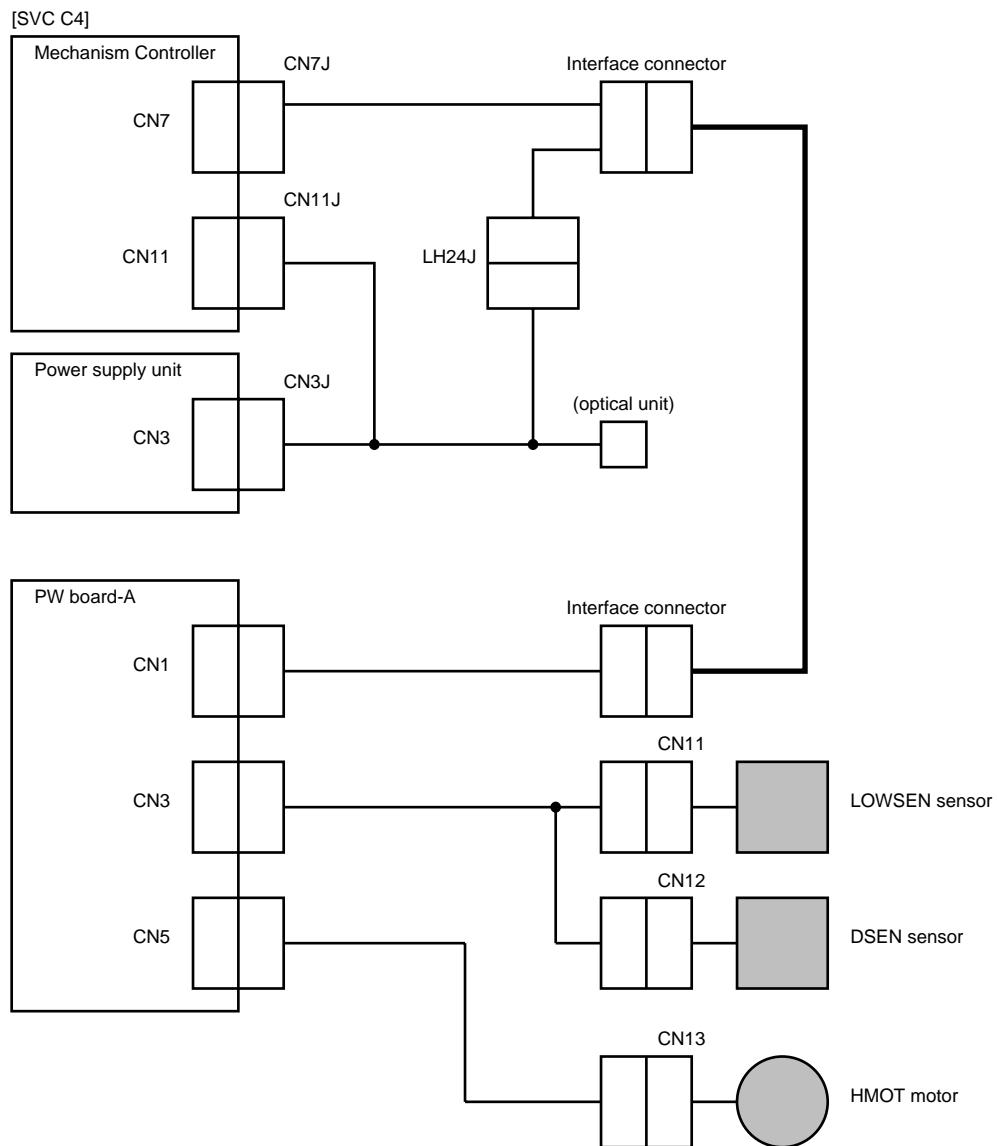

Figure 5-8. LCH Elevator Descent Alarm (SVCC4) Interconnections Diagram (1 of 2)

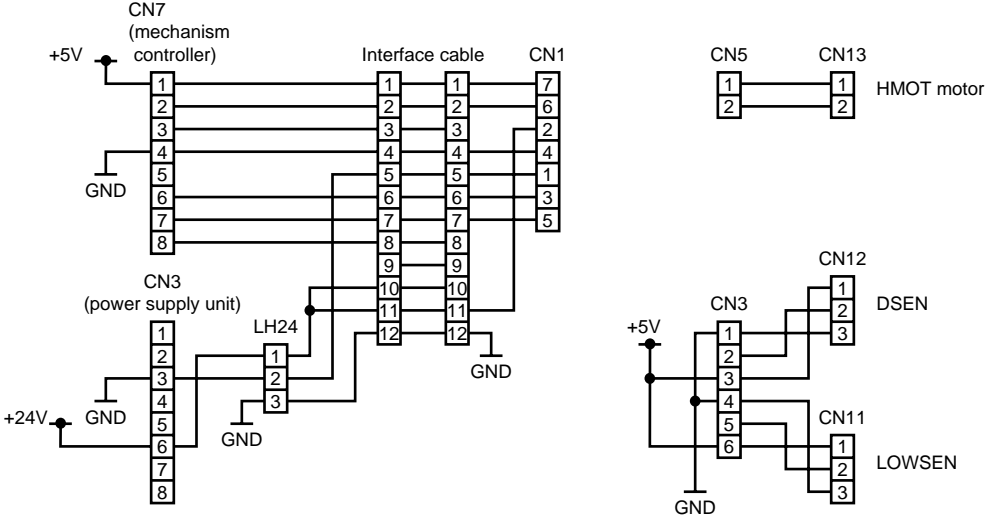

Figure 5-8. LCH Elevator Descent Alarm (SVCC4) Interconnections Diagram (2 of 2)

5-7.5. SVCC5 LCH Elevator Ascent Alarm**Explanation**

The paper raised position sensor (LEVSEN) is not blocked (the sensor output does not go low) 12 sec. after the elevator motor (HMOT) is energized.

Troubleshooting Procedure

<010> Is the paper table stopped at the top frame? <Y:012, N:020>

<012> The table driving system may already be unreparably deformed. Replace the whole LCH.

<014> Exit.

<020> Is there something clogging at the sensor LEVSEN (paper pieces, etc.)? <Y:022, N:030>

<022> Remove anything clogging at the sensor.

<024> Does this alarm still occur? (Confirm the front door of the printer is closed, then open and close the cassette door of the LCH.) <Y:030, N:Exit>

<030> Check whether the PW board-A receives the output signal from the sensor LEVSEN properly. Is the voltage across pin6 of the connector CN2 on the PW board-A and GND approx 0V when the LEVSEN is blocked? Also, when LEVSEN is unblocked, does the voltage change to approx 5V? <Y:040, N:032>

<032> Check damages or pinches of wire, cable and connector between the following connectors:
CN2 on the PW board-A and the sensor LEVSEN.

<033> Does this jam still occur? <Y:034, N:Exit>

<034> Replace the sensor LEVSEN.

<035> Does this jam still occur? <Y:040, N:Exit>

<040> After resetting the malfunction, does opening/closing the cassette door of the LCH cause the paper table to ascend? (Confirm the front door of the printer is closed.) <Y:050, N:060>

<050> Replace the PW board-A.

<052> Exit.

<060> Check damages or pinches of wire, cable, and connector between the following connectors:
CN3 on the PW board-A and the sensor DSEN,
CN5 on the PW board-A and the motor HMOT,
CN3 on the power supply PCB of the printer and the LCH interface connector,

LCH interface connector and CN1 on the PW board-A.

<062> Does this jam still occur? <Y:070, N:Exit>

<070> Replace the sensor DSEN.

<072> Does this jam still occur? <Y:080, N:Exit>

<080> Does opening/closing the cassette door of the LCH cause the motor HMOT to be applied 24V?

(Confirm the front door of the printer is closed.) <Y:050, N:090>

<090> Remove the elevator motor HMOT, then open/close the cassette door of LCH.

Does the motor rotate? <Y:012, N:100>

<100> Replace the motor HMOT (CA81003-5655, see x-xxx, fig.3-16).

<102> Exit.

Reference Diagrams

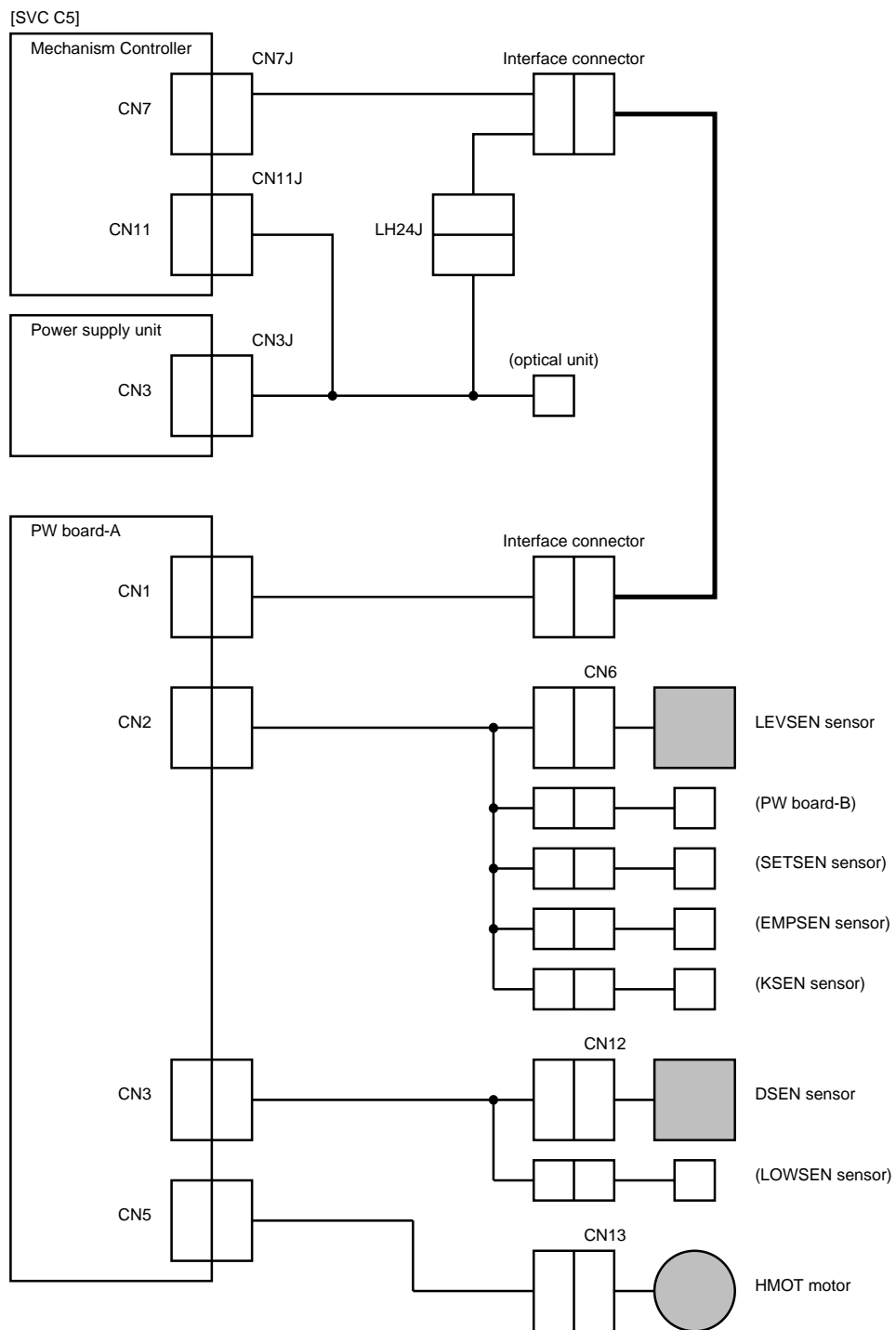

Figure 5-9. LCH Elevator Ascent Alarm (SVCC5) Interconnections Diagram (1 of 2)

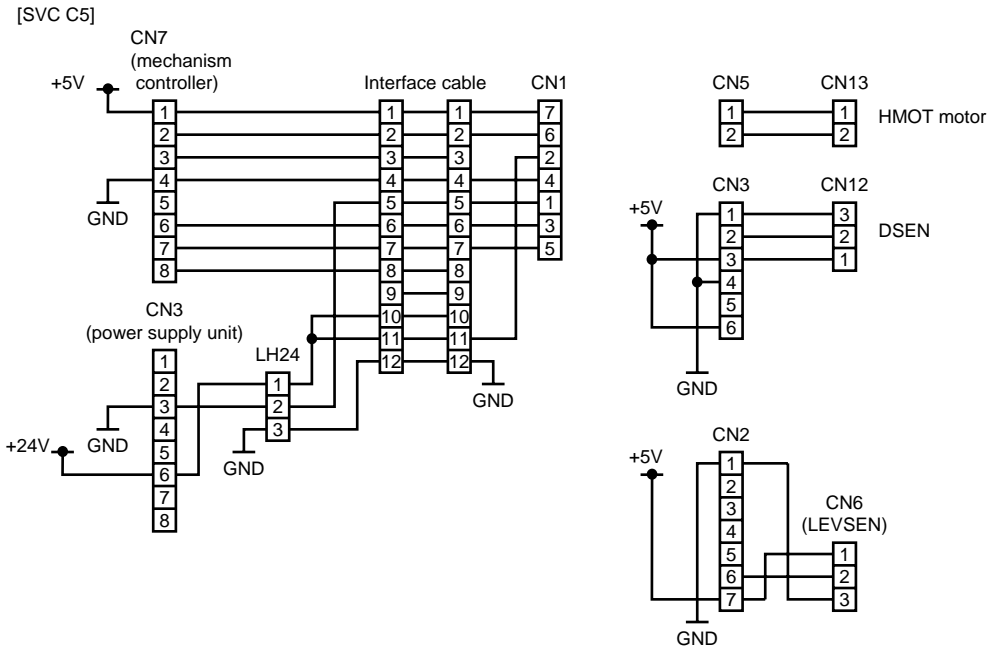

Figure 5-9. LCH Elevator Ascent Alarm (SVCC5) Interconnections Diagram (2 of 2)

5-8. LCH Miscellaneous Problems

5-8.1. LCH Sensing Problem 1

Explanation

The printer does not sense the installed LCH.

Troubleshooting Procedure

<010> Is the interface cable connected to the printer correctly? <Y:020, N:012>

<012> Connect the cable correctly.

<014> Does this problem still occur? <Y:020, N:Exit>

<020> Check damages or pinches of wire, cable, and connector between the following connectors:

CN3 on the power supply PCB of the printer and the LCH interface connector,

LCH interface connector and CN1 on the PW board-A.

<022> Does this problem still occur? <Y:030, N:Exit>

<030> Replace the PW board-A (CA81003-5656, see x-xx, fig.2-16).

Reference Diagrams

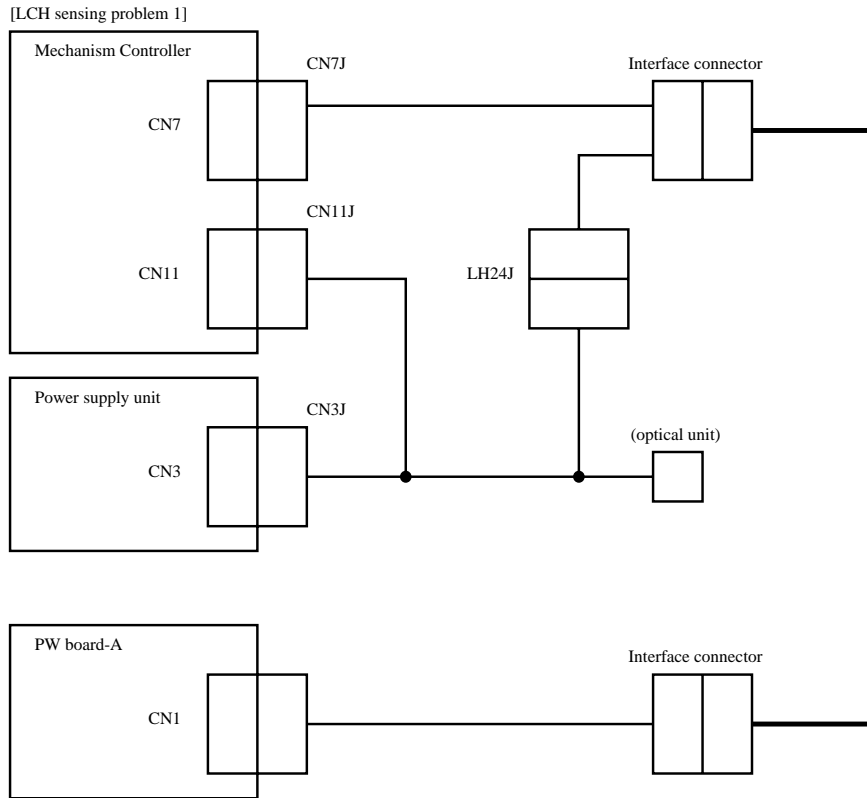

Figure 5-10. LCH Sensing Problem 1 Interconnections Diagram (1 of 2)

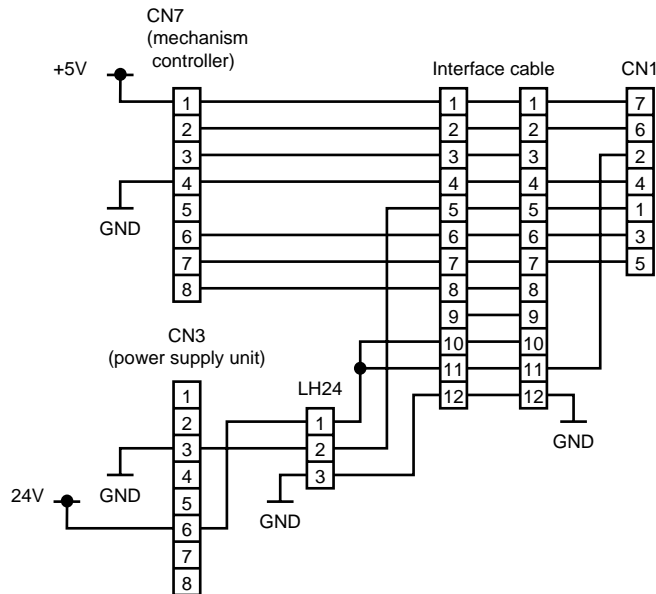

Figure 5-10. LCH Sensing Problem 1 Interconnections Diagram (2 of 2)

5-8.2. LCH Sensing Problem 2

Explanation

The printer senses the LCH although it is not installed.

Troubleshooting Procedure

<010> Check damages or pinches of wire, cable, and connector between the following connectors:
 CN7 on the mechanism controller PCB of the printer, especially for pin7, and LCH interface
 connector.

<012> Does this problem still occur? <Y:020, N:Exit>

<020> Replace the mechanism controller PCB (CA02626-J001, see 4-48, fig.4-2).

Reference Diagrams

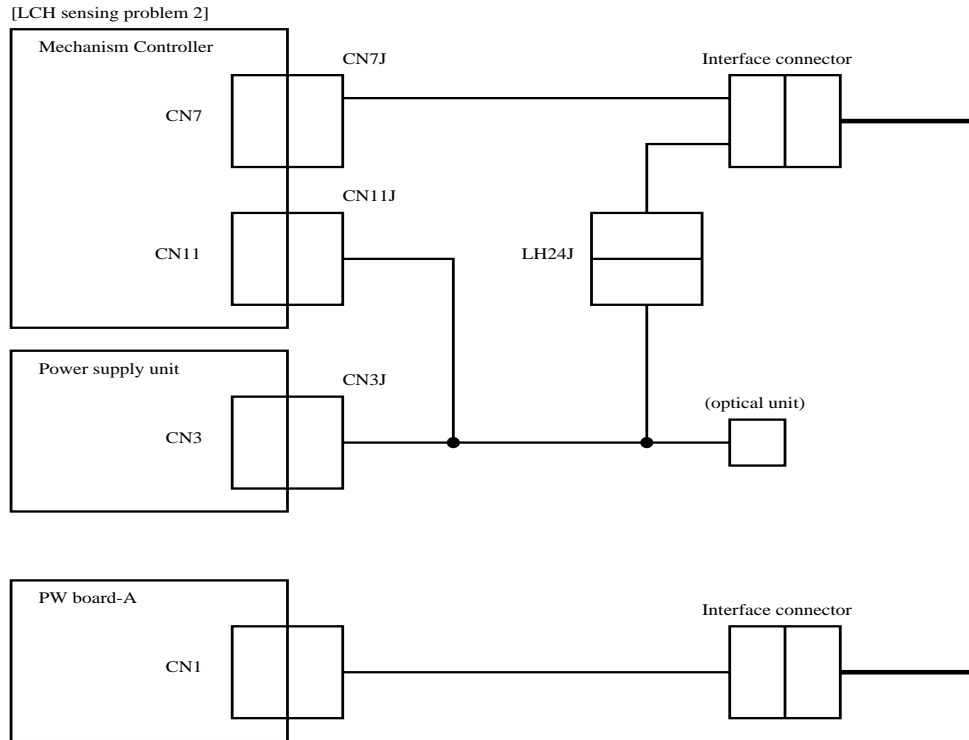

Figure 5-11. LCH Sensing Problem 2 Interconnections Diagram (1 of 2)

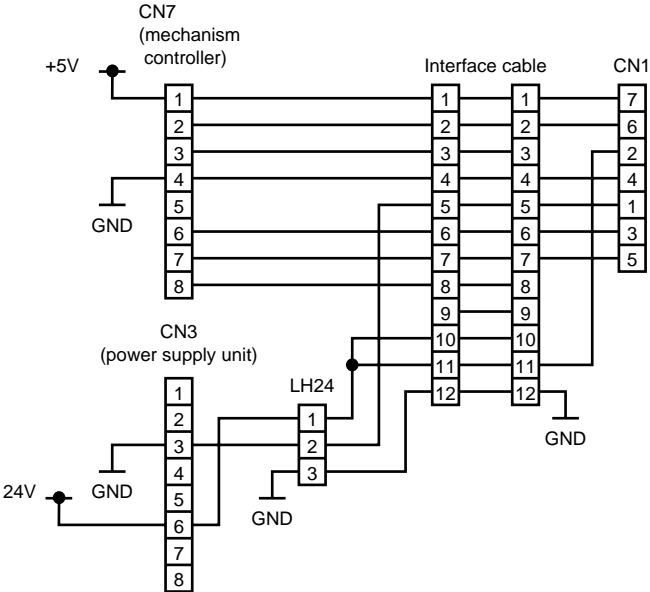

Figure 5-11. LCH Sensing Problem 2 Interconnections Diagram (2 of 2)

5-9. LCS Alarm Error Message Reported Problems

Self-Diagnosis of LCS

The LCS has the self-diagnosis feature using dip switch and LEDs on the LED unit combining with the front door interlock switch. The dip switch should be set as “0000” (all off) when normal operation. The LED’s meaning at this condition is following:

Table 5-1. dip switch = “0000” (all off)

LED No.	color of LED	description	meaning
LED3	amber	Guide sensor alarm	Being lit when the malfunction of the paper guide is detected.
LED4	red	DC motor (tray motor) alarm	Being lit when the malfunction of the paper tray ascending or descending is detected.
LED5	green	Offset alarm	Being lit when the malfunction of the paper tray offsetting is detected.
LED6	amber	Offset position	Being lit when the paper tray is in the offset position.
LED7	red	Reverse mode	Being lit when the LCS is set as reverse stacking mode by the printer.
LED8	green	Paper jam	Being lit when any paper jam in the LCS is detected.
LED9	amber	Power on	Being lit when the LCS power is turned on.

According to the setting of the dip switch and the condition of the front door, the meaning of the LEDs are changed as listed below. Note that the change of the dipswitch and the condition of the front door are recognized when the locker switch of the LCS is turned on. So you should turn off the locker switch when you change the diagnosis conditions, and you should turn on the locker switch to make the new condition effective.

(Set the dip switch=“1000” (switch 1 is on) and turn on the locker switch of the LCS, then the six LEDs are lit and off in order. Thi is the dianosis for the LED unit itself.)

Table 5-2. dip switch = “0100” (switch 2 is on) and the front door is closed

LED No.	color of LED	description	meaning
LED4	red	Paper jam 1 sensor	Being lit when a paper not actuate the sensor.
LED5	green	Paper jam 2 sensor	Being lit when a paper not actuate the sensor.

LED No.	color of LED	description	meaning
LED6	amber	(not used)	(always lit)
LED7	red	Hi-top sensor	Being lit when no paper is in front of the sensor.
LED8	green	Top sensor	Being lit when no paper is in front of the sensor.
LED9	amber	Guide sensor	Being lit when the paper guide is in the straight position.

Table 5-3. dip switch = “0100” (switch 2 is on) and the front door is open

LED No.	color of LED	description	meaning
LED4	red	Bottom switch	Being lit when the switch is not actuated.
LED5	green	Door switch	Being lit when the switch is actuated.
LED6	amber	Offset switch	Being lit when the switch is not actuated.
LED7	red	(not used)	(always off)
LED8	green	(not used)	(always off)
LED9	amber	(not used)	(always off)

Furthermore, following settings of the dipswitch can move some electrical parts automatically. The settings of the dip switch and their corresponding feature are listed below:

Table 5-4. Further features of the dip switch

setting of dip switch	feature
“1100” (switch 1 and 2 are on)	The feed motor continually rotates counterclockwise with paper feeding speed.
“0010” (switch 3 is on)	The exit motor continually rotates counterclockwise with maximum speed.
“1010” (switch 1 and 3 are on)	The offset motor mutually moves the paper tray back and forth, with stopping 1 second on every home and offset positions.
“0110” (switch 2 and 3 are on)	The tray motor mutually moves the paper tray up and down between the top sensor and the bottom switch, with stopping 3 seconds on every top and bottom positions.

setting of dip switch	feature
"1110" (switch 1 to 3 are on)	All the motors above work as above actions.

These all features above are useful to isolate the cause of the problems.

NOTE

When you check whether the problem still occur or exit the troubleshooting flow, do not forget to set the dip switch as it was "0000".

As same as the paper jams in the printer, at any paper jam in the LCS occurs, check the following items before starting the troubleshoot:

- (1) Check whether the paper being used meets the standard (especially for dimensions, thickness, smoothness, foreign particles, or something sticking the paper each other).
- (2) Check whether the paper is handled correctly (especially for creases or wrinkles).
- (3) Check whether the environment both for the printer and the paper itself meets standard (especially for humidity).
- (4) Check whether the rollers and the paper guides regarding to the jam are clean (especially for scattered toner or developer, accumulated paper powder and paper pieces).
- (5) Check whether the LCS is installed correctly aligned with the printer.

5-9.1. JAM41 LCS Stacker Jam

Explanation

Paper did not reach the paper jam 1 sensor before specified time passed after the output synchronous signal (OSYNC) was issued from the printer (at straight mode), or

Paper did not reach the paper jam 2 sensor before specified time passed after the output synchronous signal (OSYNC) was issued from the printer (at reverse mode), or

Paper did not leave the paper jam 1 sensor before specified time passed after the paper reached the paper jam 1 sensor, or

Paper did not leave the paper jam 2 sensor before specified time passed after the paper reached the paper jam 2 sensor, or

Paper did not reach the paper jam 1 sensor before specified time passed after the paper left the paper jam 2 sensor (at reverse mode).

Troubleshooting Procedure

<010> Are there any paper in the LCS when the jam occur? <Y:020, N:750>

<020> Does the jam occur when every 120 sheets stacked? <Y:600, N:030>

<030> Is the jammed paper stopped on the straight path before reaching the paper jam 1 sensor? <Y:400, N:040>

<040> Is the jammed paper stopped on the straight path after reaching the paper jam 1 sensor? <Y:550, N:050>

<050> Is the jammed paper stopped on the reversing path before reaching the paper jam 2 sensor? <Y:400, N:060>

<060> Is the jammed paper stopped on the reversing path before reaching the paper jam 1 sensor? <Y:150, N:070>

<070> Is the jammed paper stopped on the reversing path after reaching the paper jam 1 sensor? <Y:100, N:030>

<100> The problem may be on the paper jam 1 sensor. Is there something clogging near the paper jam 1 sensor (paper pieces, etc)? <Y:102, N:104>

<102> Remove anything clogging. Does this jam still occur? <Y:104, N:Exit>

<104> Once turn off the locker switch of the LCS, open the front door, and set the dip switch on the LED unit PCB "0100", then close the front door and turn on the locker switch again. (Confirm the printer is turned on and the front door of the LCS is closed. The change of the dip switch is recognized by the LCOS controller when the locker switch is turned on.)

<106> Check the paper jam 1 sensor by putting a piece of paper at the paper jam 1 sensor and

remove it, while seeing the LED4 (red LED) on the LED unit PCB. Does the LED turn on and off corresponding the paper jam 1 sensor? <Y:110, N:130>

<110> Check whether the interface cable is connected to the printer correctly. Check damages or pinches of wire, cable, and connector between the following connectors:

CN12 on the mechanism controller PCB of the printer (especially for pin17) and the LCS interface connector,

LCS interface connector and CN3 on the LCS controller PCB (especially for pin17).

<112> Does this problem still occur? <Y:114, N:Exit>

<114> Replace the LCS controller PCB.

<116> Does this jam still occur? <Y:120, N:Exit>

<120> Replace the paper feed unit.

<122> Exit.

<130> Check damages or pinches of wire, cable and connector between the following connectors:

CN2 on the LCS controller PCB and SEN1 at the paper jam 1 sensor.

<132> Does this problem still occur? <Y:140, N:Exit>

<140> Replace the paper jam 1 sensor.

<142> Exit.

<150> The problem may be on the exit motor system or the paper jam 2 sensor. Is there something clogging near the paper jam 2 sensor (paper pieces, etc)? <Y:152, N:160>

<152> Remove anything clogging. Does this jam still occur? <Y:160, N:Exit>

<160> Once turn off the locker switch of the LCS, open the front door, and set the dip switch on the LED unit PCB "0100", then close the front door and turn on the locker switch again. (Confirm the printer is turned on and the front door of the LCS is closed. The change of the dip switch is recognized by the LCS controller when the locker switch is turned on.)

<162> Check the paper jam 2 sensor by putting a piece of paper at the paper jam 1 sensor and remove it, while seeing the LED5 (green LED) on the LED unit PCB. Does the LED turn on and off corresponding the paper jam 2 sensor? <Y:170, N:220>

<170> Once turn off the locker switch of the LCS, open the front door, and set the dip switch on the LED unit PCB "0010", then close the front door and turn on the locker switch again. (Confirm the printer is turned on and the front door of the LCS is closed. The change of the dip switch is recognized by the LCOS controller when the locker switch is turned on.)

<172> Does the exit roller rotate? <Y:240, N:180>

<180> Remove the exit motor while its connector connected, then turn it by locker switch again.

<182> Does the exit motor rotate? <Y:240, N:190>

<190> Check damages or pinches of wires, cable and connector between the following connectors:

CN7 on the LCS controller PCB and M2 near the exit motor.

<192> Does this problem still occur? <Y:200, N:Exit>

<200> Replace the exit motor.

<202> Exit.

<220> Check damages or pinches of wire, cable and connector between the following connectors:

CN2 on the LCS controller PCB and SEN2 at the paper jam 2 sensor.

<222> Does this jam still occur? <Y:230, N:Exit>

<230> Replace the paper jam 2 sensor.

<232> Exit.

<240> Check the exit belt. Is there something clogging at the pulleys of the belt, or the belts twisted? <Y:242, N:250>

<242> Remove anything clogging at the belt, install the belts correctly.

<244> Does this jam still occur? <Y:250, N:Exit>

<250> Is the exit belt coming off or unrepairably damaged? <Y:252, N:260>

<252> Replace the exit belt.

<254> Does this jam still occur? <Y:260, N:Exit>

<260> Is the exit motor pulley unrepairably damaged? <Y:262, N:270>

<262> Replace the exit motor pulley.

<264> Does this jam still occur? <Y:270, N:Exit>

<270> Is the exit belt roller unrepairably damaged? <Y:272, N:280>

<272> Replace the exit belt roller.

<274> Does this jam still occur? <Y:280, N:Exit>

<280> Is the reverse roller pulley unrepairably damaged? <Y:282, N:290>

<282> Replace the reverse roller pulley.

- <284> Does this jam still occur? <Y:290, N:Exit>
- <290> Is the reverse roller unrepairably damaged? <Y:292, N:300>
- <292> Replace the reverse roller.
- <294> Does this jam still occur? <Y:300, N:Exit>
- <300> Are the reverse idlers unrepairably damaged? <Y:302, N:310>
- <302> Replace the damaged reverse idler.
- <304> Does this jam still occur? <Y:310, N:Exit>
- <310> Is the exit roller pulley unrepairably damaged? <Y:312, N:320>
- <312> Replace the exit roller pulley.
- <314> Does this jam still occur? <Y:320, N:Exit>
- <320> Is the exit roller unrepairably damaged? <Y:322, N:330>
- <322> Replace the exit roller.
- <324> Does this jam still occur? <Y:330, N:Exit>
- <330> Are the exit idlers unrepairably damaged? <Y:332, N:340>
- <332> Replace the damaged exit idler.
- <334> Does this jam still occur? <Y:340, N:Exit>
- <340> Is there any other unrepairable damage on the paper feed unit? <Y:350, N:110>
- <350> Replace the paper feed unit.
- <352> Exit.
- <400> The problem may be on the feed motor system or the paper guide. Is there something clogging in the paper feeding path, especially near the paper guide (paper pieces, etc)? <Y:402, N:410>
- <402> Remove anything clogging. Does this jam still occur? <Y:410, N:Exit>
- <410> Is there any unrepairable deformation or damage (discrepancy between each paddles of the paper guide) on the paper guide? <Y:120, N:420>

<420> Once turn off the locker switch of the LCS, open the front door, and set the dip switch on the LED unit PCB “1100”, then close the front door and turn on the locker switch again. (Confirm the printer is turned on and the front door of the LCS is closed. The change of the dip switch is recognized by the LCOS controller when the locker switch is turned on.)

<422> Does the feed roller rotate? <Y:470, N:430>

<430> Remove the feed motor while its connector connected, then turn it by locker switch again.

<432> Does the feed motor rotate? <Y:470, N:440>

<440> Check damages or pinches of wires, cable and connector between the following connectors:

CN7 on the LCS controller PCB and M1 near the feed motor.

<442> Does this problem still occur? <Y:450, N:Exit>

<450> Replace the feed motor.

<452> Exit.

<470> Is the feed motor gear unrepairably damaged? <Y:472, N:480>

<472> Replace the feed motor gear.

<474> Does this jam still occur? <Y:480, N:Exit>

<480> Is the feed roller gear unrepairably damaged? <Y:482, N:490>

<482> Replace the feed roller gear.

<484> Does this jam still occur? <Y:490, N:Exit>

<490> Is the feed roller unrepairably damaged? <Y:492, N:500>

<492> Replace the feed roller.

<494> Does this jam still occur? <Y:500, N:Exit>

<500> Are the feed idlers unrepairably damaged? <Y:502, N:340>

<502> Replace the damaged feed idler.

<504> Does this jam still occur? <Y:340, N:Exit>

<550> The problem may be on the exit motor system or the paper jam 1 sensor. Is there something clogging in the paper reversing or the exit path, especially near the paper jam 1 sensor (paper pieces, etc)? <Y:552, N:560>

<552> Remove anything clogging. Does this jam still occur? <Y:560, N:Exit>

<560> Once turn off the locker switch of the LCS, open the front door, and set the dip switch on

the LED unit PCB “0100”, then close the front door and turn on the locker switch again. (Confirm the printer is turned on and the front door of the LCS is closed. The change of the dip switch is recognized by the LCOS controller when the locker switch is turned on.)

<562> Check the paper jam 1 sensor by putting a piece of paper at the paper jam 1 sensor and remove it, while seeing the LED4 (red LED) on the LED unit PCB. Does the LED turn on and off corresponding the paper jam 1 sensor? <Y:170, N:130>

<600> The problem may be on tray driving system or hi-top sensor, or mis-detection of stacker full. Remove all the paper on the paper tray, then does this jam still occur? <Y:610, N:Exit>

<610> Once turn off the locker switch of the LCS, open the front door, and set the dip switch on the LED unit PCB “0100”, then close the front door and turn on the locker switch again. (Confirm the printer is turned on and the front door of the LCS is closed. The change of the dip switch is recognized by the LCOS controller when the locker switch is turned on.)

<612> Check the hi-top sensor by putting a piece of paper facing the hi-top sensor and remove it, while seeing the LED7 (red LED) on the LED unit PCB. Does the LED turn on and off corresponding the hi-top sensor? <Y:640, N:620>

<620> Check damages or pinches of wire, cable and connector between the following connectors:

CN2 on the LCS controller PCB and CN15 on the harness,

CN15 on the harness and SEN5 at the hi-top sensor.

<622> Does this problem still occur? <Y:630, N:Exit>

<630> Replace the hi-top sensor.

<632> Exit.

<640> Check the belts of the paper tray (one belt at the tray motor, two belts at both sides of the LCS). Is there something clogging at the pulleys of these belts, or the belts twisted? <Y:642, N:650>

<642> Remove anything clogging at the belts, install the belts correctly.

<643> Exit.

<650> Are these belts coming off or unrepairably damaged? <Y:900, N:660>

<660> Once turn off the locker switch of the LCS, open the front door, and set the dip switch on the LED unit PCB “0110”, then close the front door and turn on the locker switch again. (Confirm the printer is turned on and the front door of the LCS is closed. The change of the dip switch is recognized by the LCOS controller when the locker switch is turned on.)

<670> Does the paper tray move smoothly? <Y:790, N:680>

<680> Does the paper tray not move at all? <Y:900, N:690>

<690> Check damages or pinches of wire, cable, and connector between the following connectors:

CN6 on the LCS controller PCB and M3 near the tray motor.

<692> Does this problem still occur? <Y:700, N:Exit>

<700> Replace the tray motor.

<702> Exit.

<750> The problem may be on the paper jam 1 sensor or paper jam 2 sensor. Is there something clogging at the paper jam 1 sensor or paper jam 2 sensor (paper pieces, etc)? <Y:752, N:760>

<752> Remove anything clogging. Does this jam still occur? <Y:760, N:Exit>

<760> Once turn off the locker switch of the LCS, open the front door, and set the dip switch on the LED unit PCB “0100”, then close the front door and turn on the locker switch again. (Confirm the printer is turned on and the front door of the LCS is closed. The change of the dip switch is recognized by the LCS controller when the locker switch is turned on.)

<762> Check the paper jam 1 sensor by putting a piece of paper at the paper jam 1 sensor and remove it, while seeing the LED4 (red LED) on the LED unit PCB. Does the LED turn on and off corresponding the paper jam 1 sensor? <Y:130, N:764>

<764> Check the paper jam 2 sensor by putting a piece of paper at the paper jam 1 sensor and remove it, while seeing the LED5 (green LED) on the LED unit PCB. Does the LED turn on and off corresponding the paper jam 2 sensor? <Y:770, N:220>

<770> Check whether the interface cable is connected to the printer correctly. Check damages or pinches of wire, cable, and connector between the following connectors:

CN12 on the mechanism controller PCB of the printer and the LCOS interface connector,
LCOS interface connector and CN3 on the LCS controller PCB.

<772> Does this problem still occur? <Y:780, N:Exit>

<780> Replace the LCS controller PCB.

<782> Does this problem still occur? <Y:790, N:Exit>

<790> Replace the mechanism controller PCB of the printer.

<792> Exit.

<900> The driving mechanism may already be unrepairably deformed or damaged. Replace the whole LCS.

<902> Exit.

Reference Diagrams

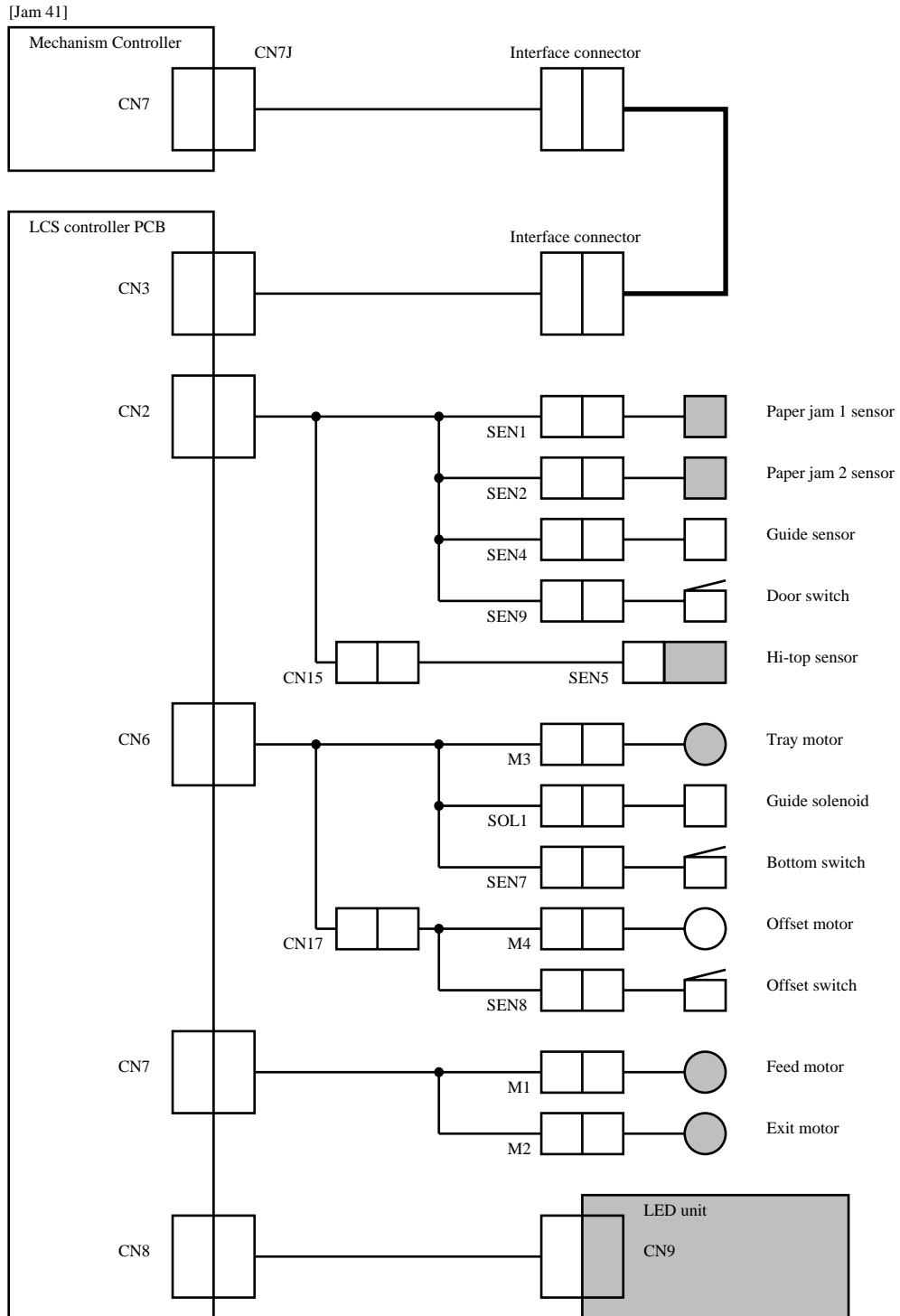

Figure 5-12. LCS Stacker Jam (JAM41) Interconnections Diagram (1 of 3)

[Jam 41]

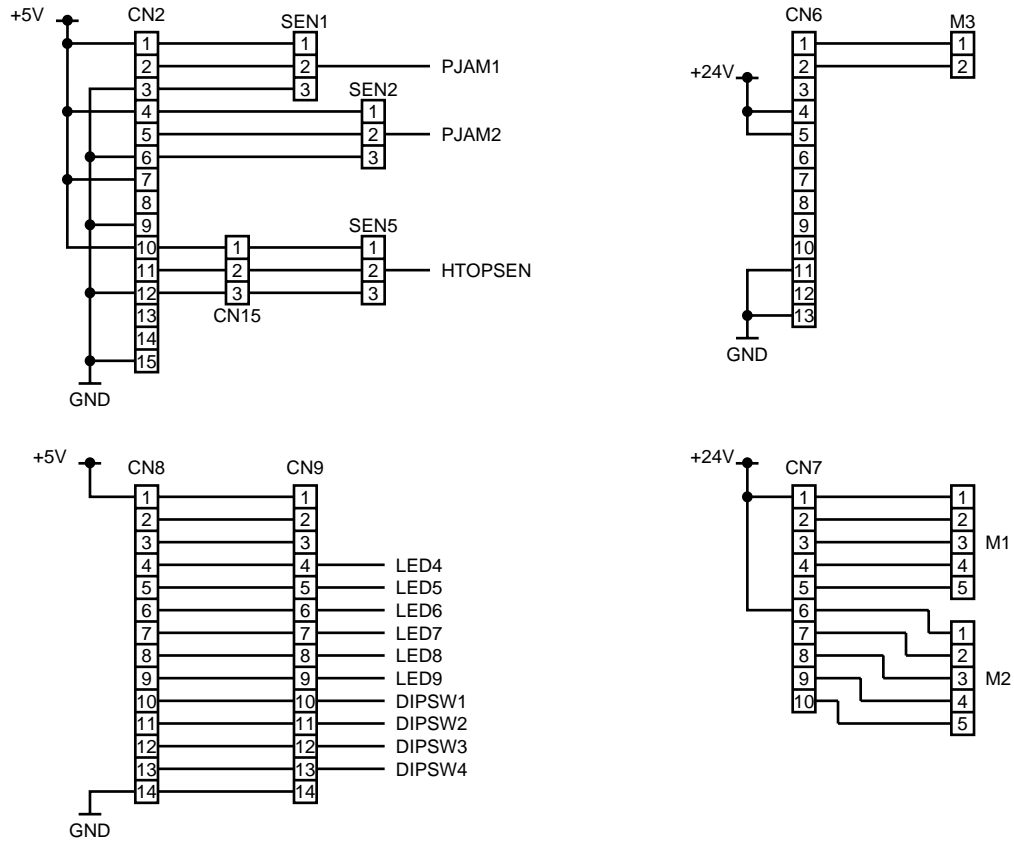

Figure 5-12. LCS Stacker Jam (JAM41) Interconnections Diagram (2 of 3)

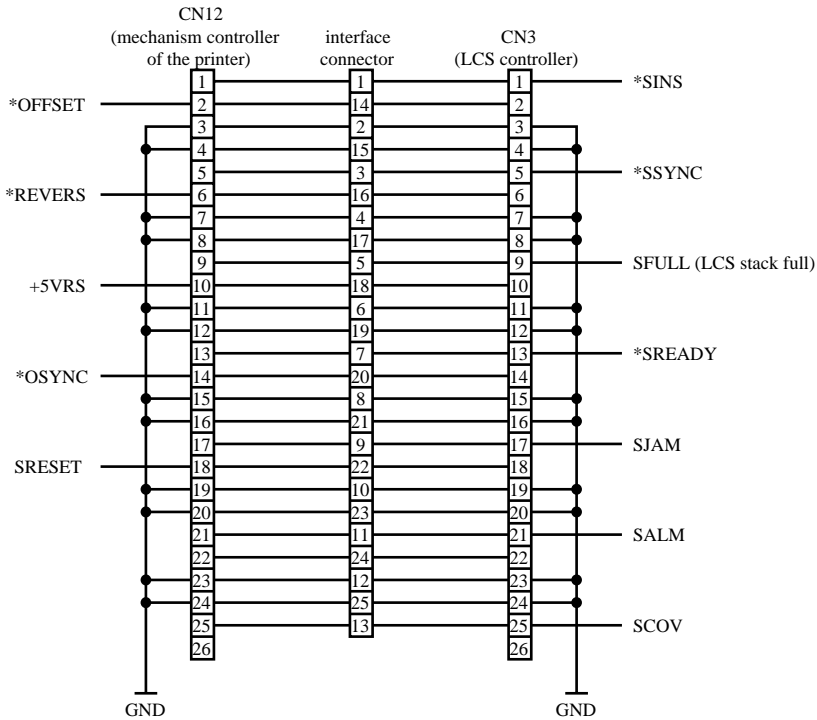

Figure 5-12. LCS Stacker Jam (JAM41) Interconnections Diagram (3 of 3)

5-9.2. SVCD8 LCS Stacker Alarm**Explanation**

The stacker ready signal (SREADY) was not detected by the mechanism controller within certain time after the printer power on, or

It was detected by the mechanism controller that the stacker alarm signal (SALM) was activated. The conditions which the SALM is activated are:

- Guide sensor alarm: It was detected from the guide sensor by the LCS controller that the paper guide was not at right position before specified time passed after the paper guide position was changed, or
- Offset alarm: It was detected from the offset sensor by the LCS controller that the paper tray was not at right position before specified time passed after the paper tray position was offset, or
- DC motor alarm: It was detected from the hi-top sensor by the LCS controller that the tray did not reach the hi-top sensor before specified time passed after the tray reached the top sensor.

Troubleshooting Procedure

<010> Open the front door of the LCS, and check the dip switch on the LED unit PCB. Is the dip switch set "0000" (all off)? <Y:020, N:012>

<012> Set the dip switch "0000" (all off).

<014> Does this problem still occur? <Y:020, N:Exit>

<020> Check whether any LED on the LED unit PCB is lit. Is the LED3 (amber LED) lit? <Y:750, N:030>

<030> Is the LED5 (green LED) lit? <Y:650, N:040>

<040> Is the LED4 (red LED) lit? <Y:300, N:050>

<050> Is any other LED lit? <Y:180, N:060>

<060> All the LEDs are not lit, then problem may on primary circuits of the power supply. Check the power cable and the circuit breaker. Is the power cable connected to appropriate AC voltage power outlet correctly? <Y:070, N:062>

<062> Turn on the circuit breaker, and connect the power cable correctly.

<064> Does this problem still occur? <Y:070, N:Exit>

<070> Is the locker switch of the LCOS set on? <Y:080, N:072>

<072> Turn the locker switch on.

<074> Does this problem still occur? <Y:080, N:Exit>

<080> Check the locker switch. Is the locker switch malfunctioned? <Y:082, N:090>

<082> Replace the locker switch.

<084> Does this problem still occur? <Y:090, N:Exit>

<090> Check whether the interface cable is connected to the printer correctly. Check damages or pinches of wire, cable, and connector between the following connectors:

CN12 on the mechanism controller PCB of the printer and the LCS interface connector,
LCOS interface connector and CN3 on the LCS controller PCB.

<092> Does this problem still occur? <Y:100, N:Exit>

<100> Is the fuse on the power supply unit blown? <Y:110, N:150>

<110> Is there something conductive on the power supply PCB? <Y:112, N:114>

<112> Remove anything conductive on the power supply PCB.

<114> Replace the fuse on the power supply PCB (125V, 5A).

<116> Does this problem still occur? <Y:120, N:Exit>

<120> Is the fuse on the power supply unit blown again? <Y:130, N:020>

<130> Replace the power supply PCB (100V or 200V).

<132> Exit.

<150> Check the voltage at the pin 3 of the connector CN31 on the power supply PCB. When checking the voltage, turn the printer on. Is the voltage approximate 5V? <Y:152, N:130>

<152> Check the voltage between the pin 3 and pin 4 of the connector CN1 on the LCS controller PCB. Is the voltage approximate 5V? <Y:160, N:154>

<154> Check damages or pinches of wire, cable and connector between the following connectors:

CN31 on the power supply PCB and CN1 on the LCS controller PCB.

<156> Exit.

<160> Replace the LCS controller PCB.

<162> Exit.

<180> Once turn off the locker switch of the LCS, open the front door, and set the dip switch on the LED unit PCB "1000", then close the front door and turn on the locker switch again. (Confirm the printer is turned on and the front door of the LCS is closed. The change of the dip switch is recognized by the LCOS controller when the locker switch is turned on.)

<182> Are the LEDs on the LED unit PCB lit and off in order? <Y:190, N:184>

<184> Check damages or pinches of wire, cable and connector between the following connectors:

CN8 on the LCS controller PCB and LED unit PCB.

<186> Replace the LED unit PCB. <go to 020>

<190> Check whether the interface cable is connected to the printer correctly. Check damages or pinches of wire, cable, and connector between the following connectors:

CN12 on the mechanism controller PCB of the printer and the LCS interface connector,

LCOS interface connector and CN3 on the LCS controller PCB.

<192> Does this problem still occur? <Y:194, N:Exit>

<194> Replace the LCS controller PCB.

<196> Does this problem still occur? <Y:200, N:Exit>

<200> Replace the mechanism controller PCB of the printer.

<202> Exit.

<300> Is the fuse on the LCS controller PCB blown? <Y:310, N:600>

<310> The problem may be an overload on the 24V circuits. Is the paper tray stopped at the top position? <Y:320, N:350>

<320> Once turn off the locker switch of the LCS, open the front door, and set the dip switch on the LED unit PCB "0100", then close the front door and turn on the locker switch again. (Confirm the printer is turned on and the front door of the LCS is closed. The change of the dip switch is recognized by the LCS controller when the locker switch is turned on.)

<322> Check the hi-top sensor by putting a piece of paper facing the hi-top sensor and remove it, while seeing the LED7 (red LED) on the LED unit PCB. Does the LED turn on and off corresponding the hi-top sensor? <Y:400, N:330>

<330> Check damages or pinches of wire, cable and connector between the following connectors:

CN2 on the LCS controller PCB and CN15 on the harness,

CN15 on the harness and SEN5 at the hi-top sensor.

<332> Does this problem still occur? <Y:340, N:Exit>

<340> Replace the hi-top sensor and the fuse on the LCS controller PCB (24V, 3A).

<342> Exit.

<350> Is the paper tray stopped at the bottom position? (Is the bottom switch actuated?) <Y:360, N:400>

<360> Once turn off the locker switch of the LCS, open the front door, and set the dip switch on the LED unit PCB "0100", then turn on the locker switch again with the front door is open. (Confirm the printer is turned on and the front door of the LCS is open. The change of the dip switch is recognized by the LCS controller when the locker switch is turned on.)

<362> Check the bottom switch by pressing the actuator of the bottom switch by hand, while seeing the LED4 (red LED) on the LED unit PCB. Does the LED turn on and off corresponding the bottom switch? <Y:400, N:370>

<370> Check damages or pinches of wire, cable and connector between the following connectors:
CN6 on the LCS controller PCB and SEN7 at the bottom switch.

<372> Does this problem still occur? <Y:380, N:Exit>

<380> Replace the bottom switch and the fuse on the LCS controller PCB (24V, 3A).

<382> Exit.

<400> Can you move the paper tray up or down while turning the tray motor by hand? <Y:410, N:540>

<410> Is the resistance between pin 4 of the CN6 on the LCS controller PCB and FG approximate 0 ohm? <Y:420, N:160>

<420> Disconnect the connector CN6 on the LCS controller PCB.

<430> Is the resistance between pin 4 of the CN6 on the LCS controller PCB (PCB side, not harness side) and FG 50 ohms or more? <Y:490, N:435>

<435> Disconnect the connector CN7 on the LCOS controller PCB.

<440> Is the resistance between pin 4 of the CN6 on the LCS controller PCB (PCB side, not harness side) and FG 50 ohms or more? <Y:445, N:160>

<445> Disconnect the connector M1 near the feed motor, and connect the CN7 on the LCS controller PCB as it was.

<450> Is the resistance between pin 4 of the CN6 on the LCS controller PCB (PCB side, not harness side) and FG 50 ohms or more? <Y:452, N:455>

<452> Replace the feed motor and the fuse on the LCS controller PCB (24V, 3A).

<453> Exit.

<455> Disconnect the connector M2 near the exit motor.

<460> Is the resistance between pin 4 of the CN6 on the LCS controller PCB (PCB side, not harness side) and FG 50 ohms or more? <Y:462, N:470>

<462> Replace the exit motor and the fuse on the LCS controller PCB (24V, 3A).

<463> Exit.

<470> Check damages or pinches of wire, cable and connector between the following connectors:

CN7 on the LCS controller PCB and M1 near the feed motor,

CN7 on the LCS controller PCB and M2 near the exit motor.

<480> Replace the fuse on the LCS controller PCB (24V, 3A).

<482> Exit.

<490> Disconnect the M3 connector near the tray motor, connect the CN6 on the LCOS controller PCB as it was.

<500> Is the resistance between pin 4 of the CN6 on the LCS controller PCB (PCB side, not harness side) and FG 50 ohms or more? <Y:502, N:505>

<502> Replace the tray motor and the fuse on the LCS controller PCB (24V, 3A).

<503> Exit.

<505> Disconnect the connector SOL1 near the guide solenoid.

<510> Is the resistance between pin 4 of the CN6 on the LCS controller PCB (PCB side, not harness side) and FG 50 ohms or more? <Y:512, N:515>

<512> Replace the guide solenoid and the fuse on the LCS controller PCB (24V, 3A).

<513> Exit.

<515> Disconnect the connector M4 near the offset motor.

<520> Is the resistance between pin 4 of the CN6 on the LCS controller PCB (PCB side, not harness side) and FG 50 ohms or more? <Y:522, N:530>

<522> Replace the offset motor assembly and the fuse on the LCS controller PCB (24V, 3A).

<523> Exit.

<530> Check damages or pinches of wire, cable and connector between the following connectors:

CN6 on the LCS controller PCB and M3 near the tray motor,

CN6 on the LCS controller PCB and M4 near the offset motor,

CN6 on the LCS controller PCB and SOL1 near the guide solenoid.

<532> Exit.

<540> Check the belts of the paper tray (one belt at the tray motor, two belts at both sides of the LCS). Is there something clogging at the pulleys of these belts, or the belts twisted? <Y:542, N:550>

<542> Remove anything clogging at the belts, install the belts correctly.

<543> Exit.

<550> Remove the tray motor.

<552> Can you rotate the tray motor by hand? <Y:560, N:502>

<560> The paper tray driving mechanism may already be unrepairably deformed or damaged. Replace the whole LCS.

<562> Exit.

<600> The problem may be at the paper tray driving mechanism. Check the belts of the paper tray (one belt at the tray motor, two belts at both sides of the LCOS). Is there something clogging at the pulleys of these belts, or the belts twisted? <Y:602, N:610>

<602> Remove anything clogging at the belts, install the belts correctly.

<603> Exit.

<610> Are these belts coming off or unrepairably damaged? <Y:560, N:620>

<620> Once turn off the locker switch of the LCS, open the front door, and set the dip switch on the LED unit PCB "0110", then close the front door and turn on the locker switch again. (Confirm the printer is turned on and the front door of the LCS is closed. The change of the dip switch is recognized by the LCOS controller when the locker switch is turned on.)

<622> Does the paper tray move smoothly? <Y:160, N:624>

<624> Does the paper tray not move at all? <Y:630, N:560>

<630> Check damages or pinches of wire, cable, and connector between the following connectors:
CN6 on the LCS controller PCB and M3 near the tray motor.

<632> Does this problem still occur? <Y:640, N:Exit>

<640> Replace the tray motor.

<642> Exit.

<650> LCS controller PCB detected the offset alarm. The problem may be in the paper tray offset mechanism. Is the fuse on the LCS controller blown? <Y:310, N:660>

<660> Once turn off the locker switch of the LCS, open the front door, and set the dip switch on the LED unit PCB "0100", then turn on the locker switch again with the front door is open. (Confirm the printer is turned on and the front door of the LCS is open. The change of the dip switch is recognized by the LCS controller when the locker switch is turned on.)

<662> Check the offset switch by pressing the actuator of the offset switch by hand, while seeing the LED6 (amber LED) on the LED unit PCB. Does the LED turn on and off corresponding the

bottom switch? <Y:670, N:664>

<664> Check damages or pinches of wire, cable and connector between the following connectors:

CN6 on the LCS controller PCB and CN17 on the harness,

CN17 on the harness and SEN8 at the offset switch.

<666> Does this problem still occur? <Y:380, N:Exit>

<668> Replace the offset switch.

<669> Exit.

<670> Once turn off the locker switch of the LCS, open the front door, and set the dip switch on the LED unit PCB “1010”, then close the front door and turn on the locker switch again. (Confirm the printer is turned on and the front door of the LCS is closed. The change of the dip switch is recognized by the LCS controller when the locker switch is turned on.)

<672> Does the paper tray offset smoothly? <Y:160, N:674>

<674> Does the paper tray not offset at all? <Y:680, N:900>

<680> Remove the offset motor.

<682> Can you rotate the offset motor by hand? <Y:690, N:684>

<684> Replace the offset motor assembly.

<686> Exit.

<690> Check damages or pinches of wire, cable, and connector between the following connectors:
CN6 on the LCS controller PCB and CN17 on the harness,
CN17 on the harness and M4 at the offset motor.

<692> Does this problem still occur? <Y:694, N:Exit>

<694> Replace the offset motor assembly.

<696> Does this problem still occur? <Y:700, N:Exit>

<700> Replace the LCS controller PCB.

<702> Does this problem still occur? <Y:900, N:Exit>

<750> Once turn off the locker switch of the LCS, open the front door, and set the dip switch on the LED unit PCB “0100”, then close the front door and turn on the locker switch again. (Confirm the printer is turned on and the front door of the LCS is closed. The change of the dip switch is recognized by the LCOS controller when the locker switch is turned on.)

<752> Check the guide sensor by putting a piece of paper at the guide sensor and remove it, while seeing the LED9 (amber LED) on the LED unit PCB. Does the LED turn on and off corresponding the guide sensor? <Y:770, N:760>

<760> Check damages or pinches of wire, cable and connector between the following connectors:
CN2 on the LCS controller PCB and SEN4 at the guide sensor.

<762> Does this problem still occur? <Y:764, N:Exit>

<764> Replace the guide sensor.

<766> Exit.

<770> Once turn off the locker switch of the LCS, open the front door, and set the dip switch on

the LED unit PCB “1100”, then close the front door and turn on the locker switch again. (Confirm the printer is turned on and the front door of the LCS is closed. The change of the dip switch is recognized by the LCS controller when the locker switch is turned on.)

<772> Does the feed roller rotate? <Y:810, N:780>

<780> Remove the feed motor while its connector connected, then turn it by locker switch again.

<782> Does the feed motor rotate? <Y:840, N:790>

<790> Check damages or pinches of wires, cable and connector between the following connectors:

CN7 on the LCS controller PCB and M1 near the feed motor.

<792> Does this problem still occur? <Y:794, N:Exit>

<794> Replace the feed motor.

<796> Exit.

<810> Check damages or pinches of wires, cable and connector between the following connectors:

CN6 on the LCS controller PCB and SOL1 near the guide solenoid.

<812> Does this problem still occur? <Y:820, N:Exit>

<820> Replace the guide solenoid.

<822> Does this problem still occur? <Y:160, N:Exit>

<840> Is the feed motor gear damaged? <Y:842, N:850>

<842> Replace the feed motor gear.

<844> Does this problem still occur? <Y:850, N:Exit>

<850> Is the feed roller gear damaged? <Y:852, N:860>

<852> Replace the feed roller gear.

<854> Does this problem still occur? <Y:860, N:Exit>

<860> Is the guide gear damaged? <Y:862, N:870>

<862> Replace the guide gear.

<864> Does this problem still occur? <Y:870, N:Exit>

<870> Is the feed roller damaged? <Y:872, N:880>

<872> Replace the feed roller.

<874> Does this problem still occur? <Y:880, N:Exit>

<880> Is there any unrepairable damage on the paper guide? <Y:882, N:160>

<882> Replace the paper feed unit.

<884> Does this problem still occur? <Y:160, N:Exit>

<900> The driving mechanism may already be unrepairably deformed or damaged. Replace the whole LCS.

<902> Exit.

Reference Diagrams

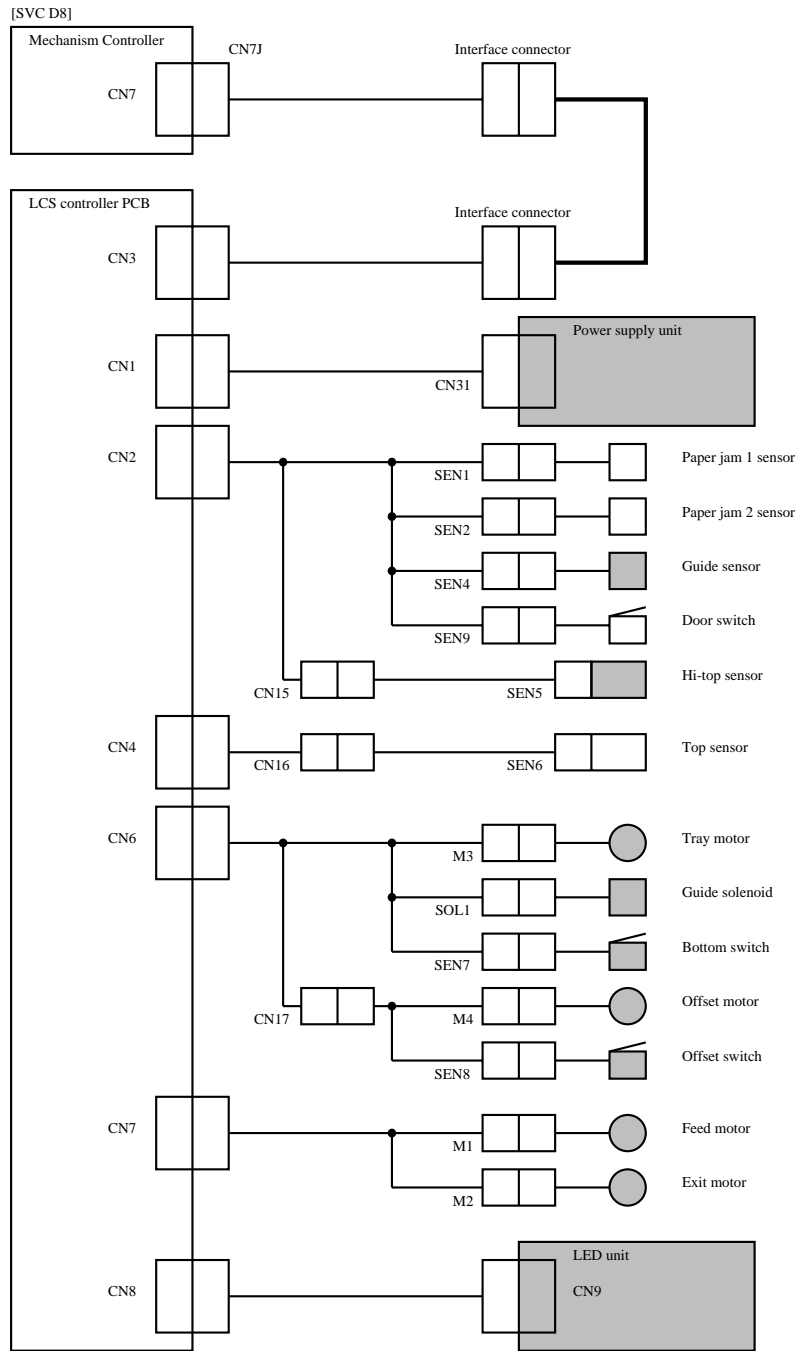

Figure 5-13. LCS Stacker Alarm (SVCD8) Interconnections Diagram (1 of 3)

[Jam 41]

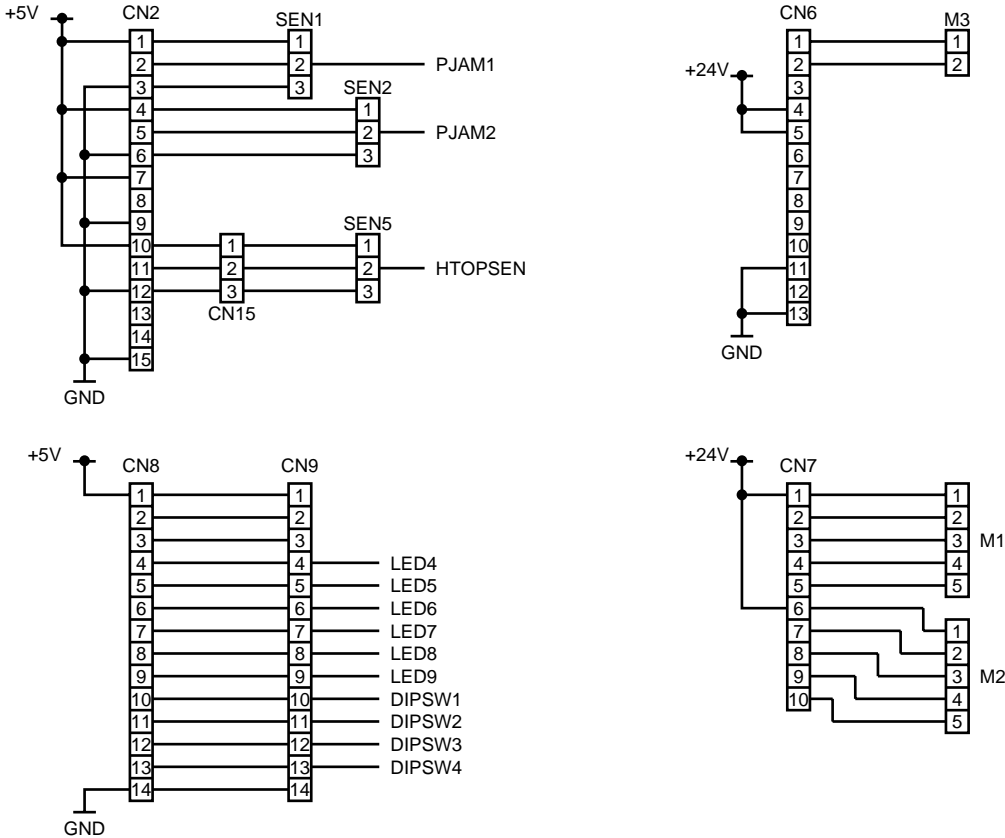

Figure 5-13. LCS Stacker Alarm (SVCD8) Interconnections Diagram (2 of 3)

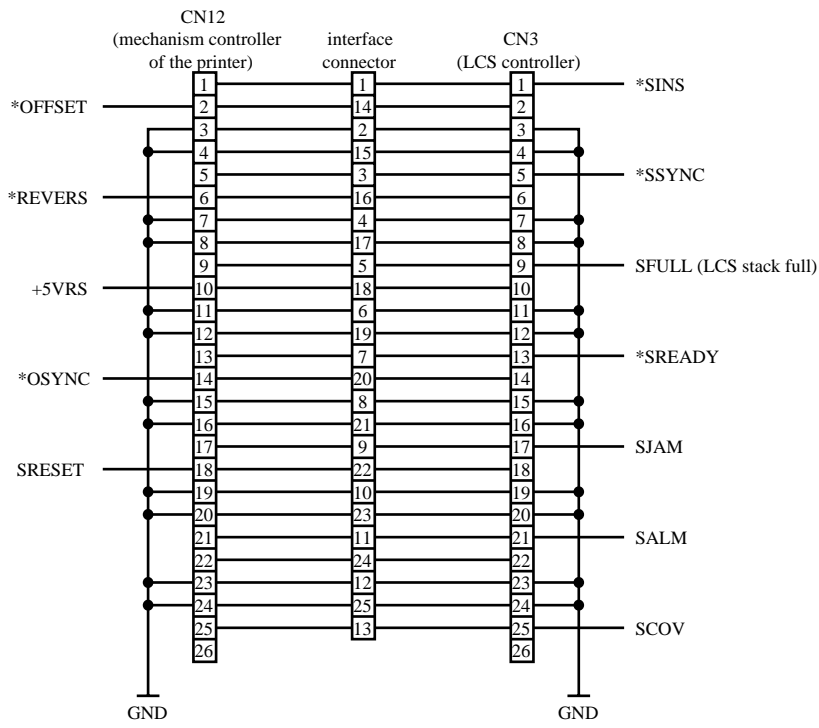

Figure 5-13. LCS Stacker Alarm (SVCD8) Interconnections Diagram (3 of 3)

5-10. LCS Miscellaneous Problems

5-10.1. LCS Stacker Full Related Problems

Explanation

The stacker full of the LCS cannot be cleared.

Troubleshooting Procedure

<010> Is there any external light shining at the hi-top sensor? <Y:020, N:012>

<012> Remove or turn off the external light.

<014> Does this problem still occur? <Y:020, N:Exit>

<020> Once turn off the locker switch of the LCS, open the front door, and set the dip switch on the LED unit PCB "0100", then close the front door and turn on the locker switch again. (Confirm the printer is turned on and the front door of the LCS is closed. The change of the dip switch is recognized by the LCS controller when the locker switch is turned on.)

<030> Is the paper tray stopped at the bottom position? (Is the bottom switch actuated?) <Y:040, N:050>

<040> Check the top sensor by putting a piece of paper facing the top sensor and remove it, while seeing the LED8 (green LED) on the LED unit PCB. Does the LED turn on and off corresponding the top sensor? <Y:050, N:100>

<050> Check the hi-top sensor by putting a piece of paper facing the hi-top sensor and remove it, while seeing the LED7 (red LED) on the LED unit PCB. Does the LED turn on and off corresponding the top sensor? <Y:060, N:200>

<060> Once turn off the locker switch of the LCS, open the front door, and set the dip switch on the LED unit PCB "0100", then turn on the locker switch again with the front door is open. (Confirm the printer is turned on and the front door of the LCS is open. The change of the dip switch is recognized by the LCS controller when the locker switch is turned on.)

<070> Check the bottom switch by pressing the actuator of the bottom switch by hand, while seeing the LED4 (red LED) on the LED unit PCB. Does the LED turn on and off corresponding the bottom switch? <Y:080, N:300>

<080> Check damages or pinches of wire, cable, and connector between the following connectors:

CN12 on the mechanism controller PCB of the printer (especially for the pin9) and the LCS interface connector,

LCS interface connector and CN3 on the LCS controller PCB (especially for the pin9).

<082> Does this problem still occur? <Y:090, N:Exit>

<090> Replace the LCS controller PCB.

<092> Exit.

<100> Check damages or pinches of wire, cable and connector between the following connectors:
CN4 on the LCS controller PCB and CN16 on the harness,
CN16 on the harness and SEN6 at the top sensor.

<110> Does this problem still occur? <Y:120, N:Exit>

<120> Replace the top sensor.

<130> Does this problem still occur? <Y:050, N:Exit>

<200> Check damages or pinches of wire, cable and connector between the following connectors:
CN2 on the LCS controller PCB and CN15 on the harness,
CN15 on the harness and SEN5 at the hi-top sensor.

<210> Does this problem still occur? <Y:220, N:Exit>

<220> Replace the hi-top sensor.

<230> Does this problem still occur? <Y:060, N:Exit>

<300> Check damages or pinches of wire, cable and connector between the following connectors:
CN6 on the LCS controller PCB and SEN7 at the bottom switch.

<310> Does this problem still occur? <Y:320, N:Exit>

<320> Replace the bottom switch.

<330> Does this problem still occur? <Y:080, N:Exit>

NOTE

When you check whether the problem still occur or exit the troubleshooting flow, do not forget to set the dip switch as it was "0000".

Troubleshooting Procedure

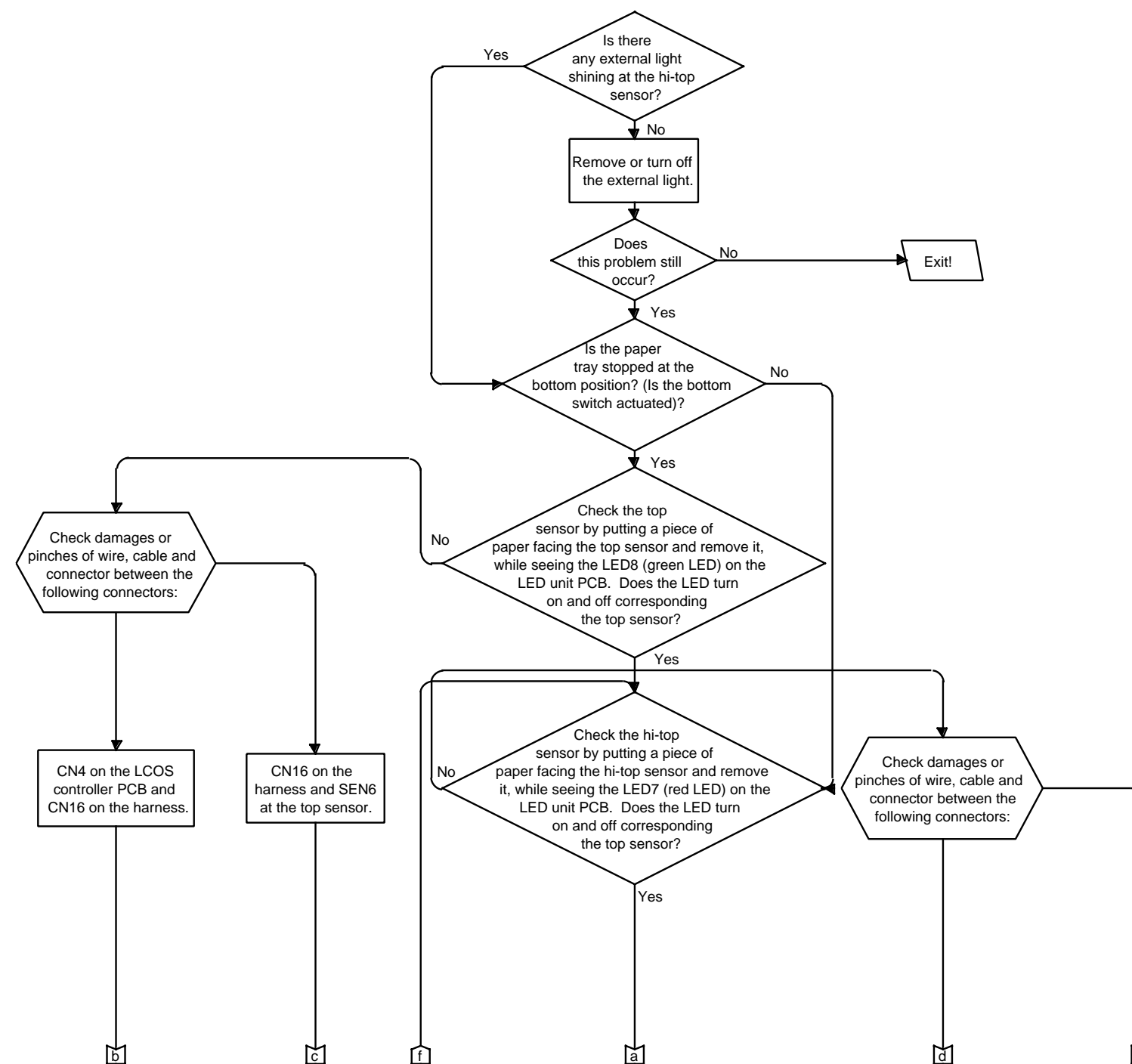

Figure 5-164. LCS Stacker Full Related Problems Flow Chart (1 of 2)

Reference Diagrams

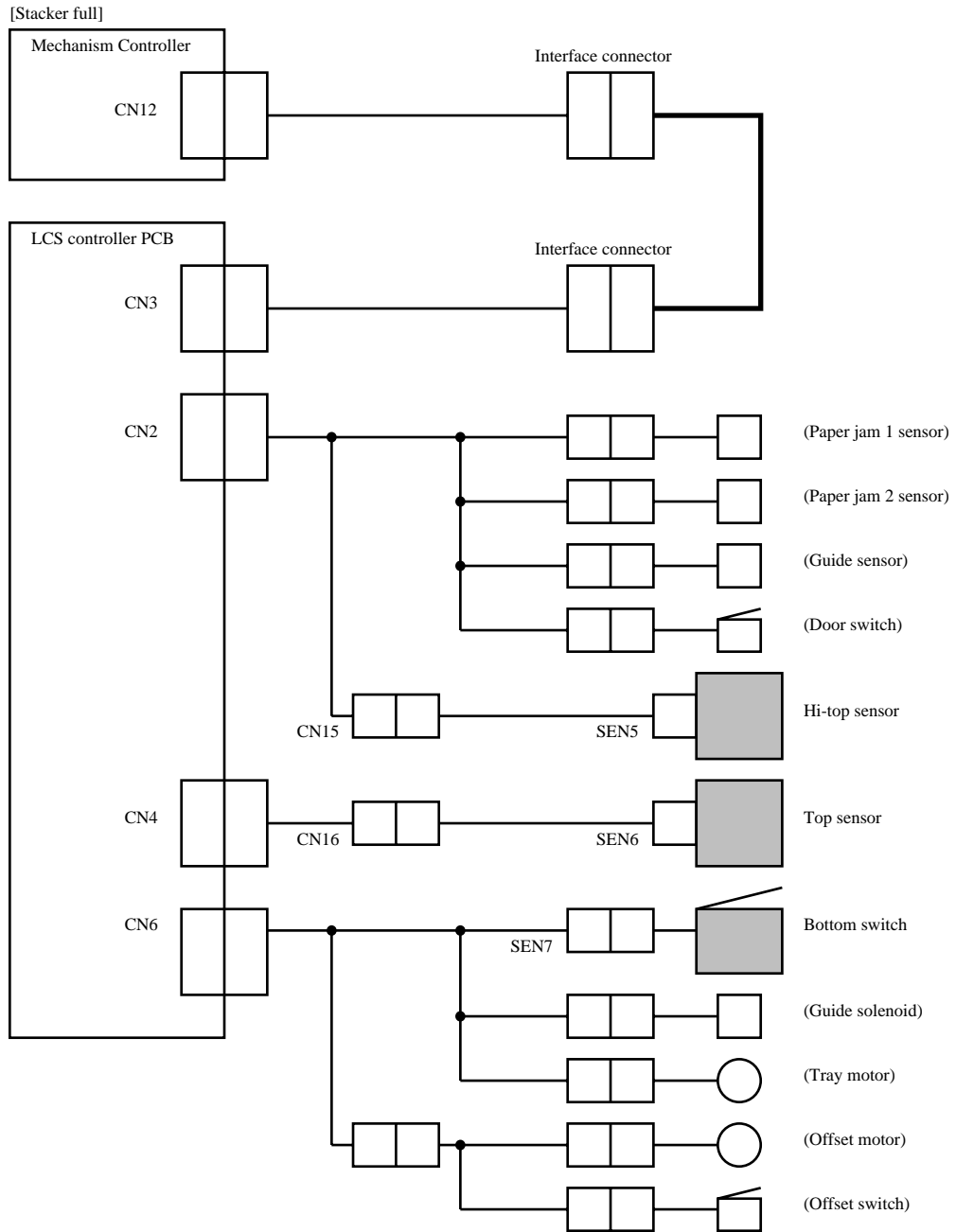

Figure 5-5. LCS Stacker Full Related Problems Interconnections Diagram (1 of 3)

[Stacker full]

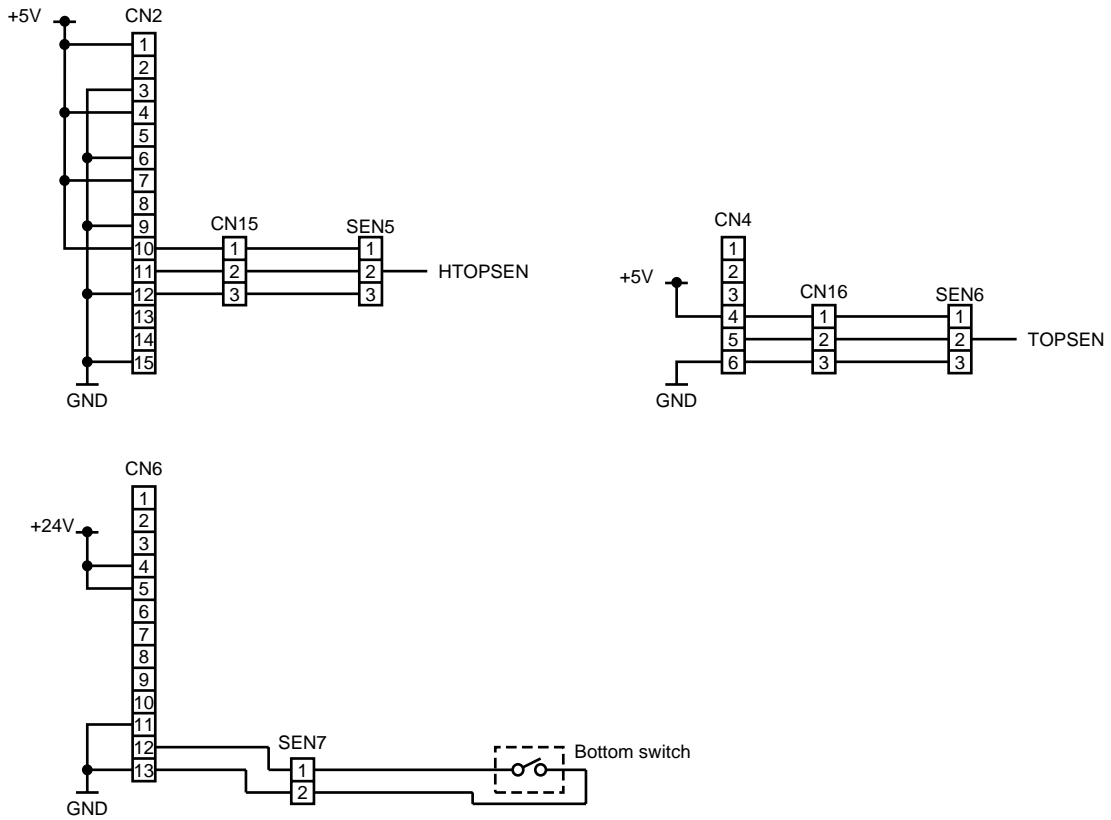

Figure 5-5. LCS Stacker Full Related Problems Interconnections Diagram (2 of 3)

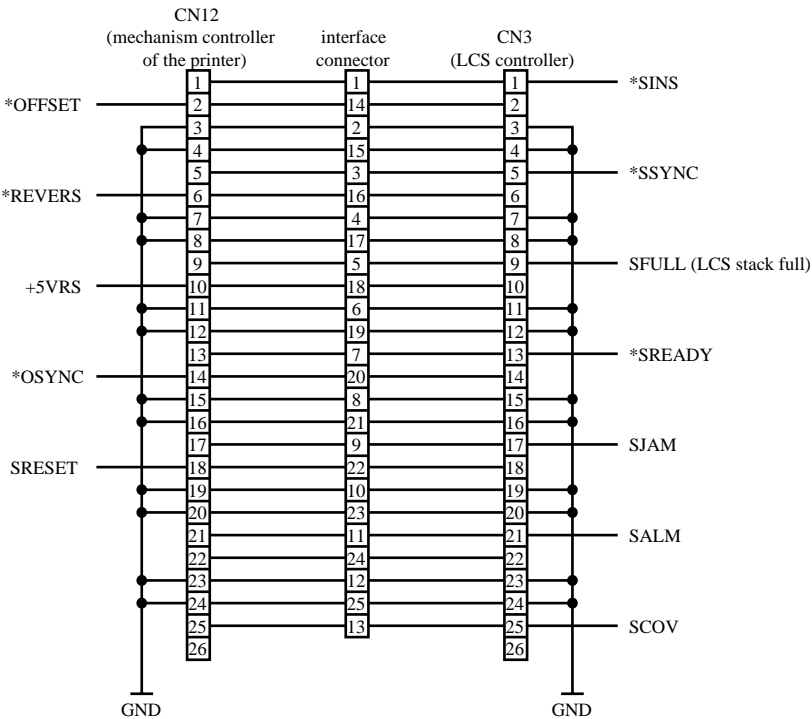

Figure 5-5. LCS Stacker Full Related Problems Interconnections Diagram (3 of 3)

5-10.2. LCS Door Open Related Problems**Explanation**

The interlock of the front door of the LCS was detected.

Troubleshooting Procedure

<010> Is the actuator behind the front door deformed or damaged? <Y:012, N:020>

<012> Replace the front door.

<014> Does this problem still occur? <Y:020, N:Exit>

<020> Once turn off the locker switch of the LCS, open the front door, and set the dip switch on the LED unit PCB "0100", then turn on the locker switch again with the front door is open. (Confirm the printer is turned on and the front door of the LCS is open. The change of the dip switch is recognized by the LCS controller when the locker switch is turned on.)

<030> Check the door switch by pressing the actuator of the door switch by hand, while seeing the LED5 (green LED) on the LED unit PCB. Does the LED turn on and off corresponding the bottom switch? <Y:100, N:040>

<040> Check damages or pinches of wire, cable, and connector between the following connectors:
CN12 on the mechanism controller PCB of the printer (especially for the pin25) and the LCS interface connector,

LCS interface connector and CN3 on the LCS controller PCB (especially for the pin25).

<042> Does this problem still occur? <Y:050, N:Exit>

<050> Replace the LCS controller PCB.

<052> Exit.

<100> Check damages or pinches of wire, cable and connector between the following connectors:
CN2 on the LCS controller PCB and SEN9 at the door switch.

<110> Does this problem still occur? <Y:120, N:Exit>

<120> Replace the door switch.

<130> Does this problem still occur? <Y:040, N:Exit>

NOTE

When you check whether the problem still occur or exit

the troubleshooting flow, do not forget to set the dip switch as it was "0000".

Reference Diagrams

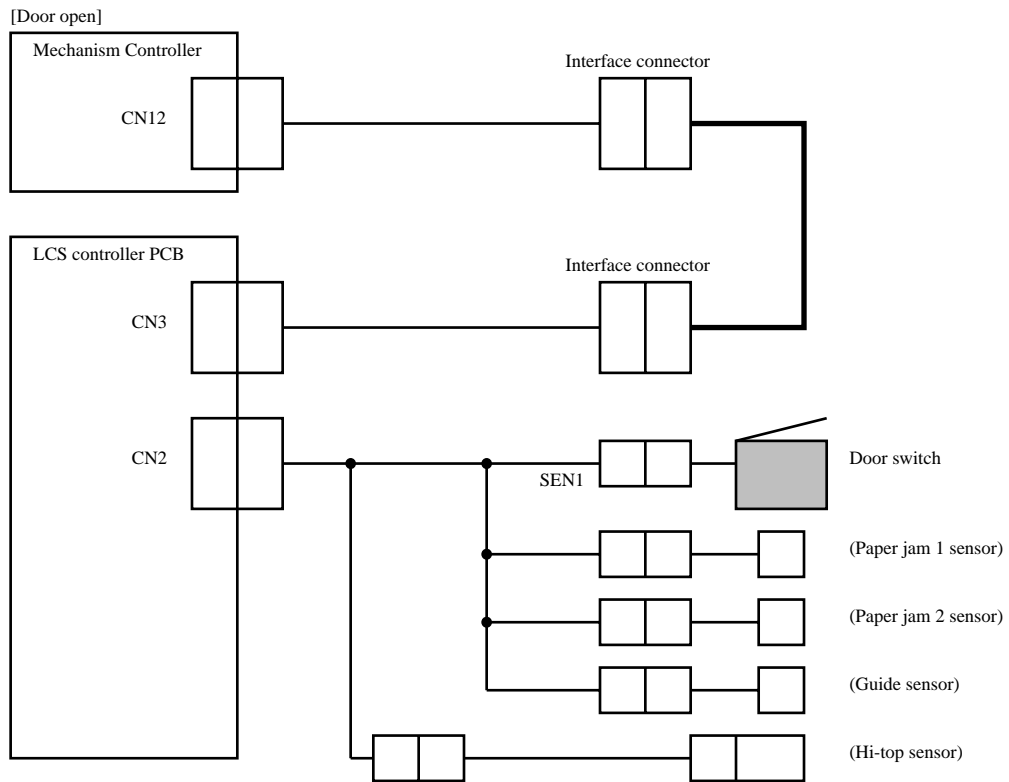

Figure 5-6. LCS Door Open Related Problems Interconnections Diagram (1 of 2)

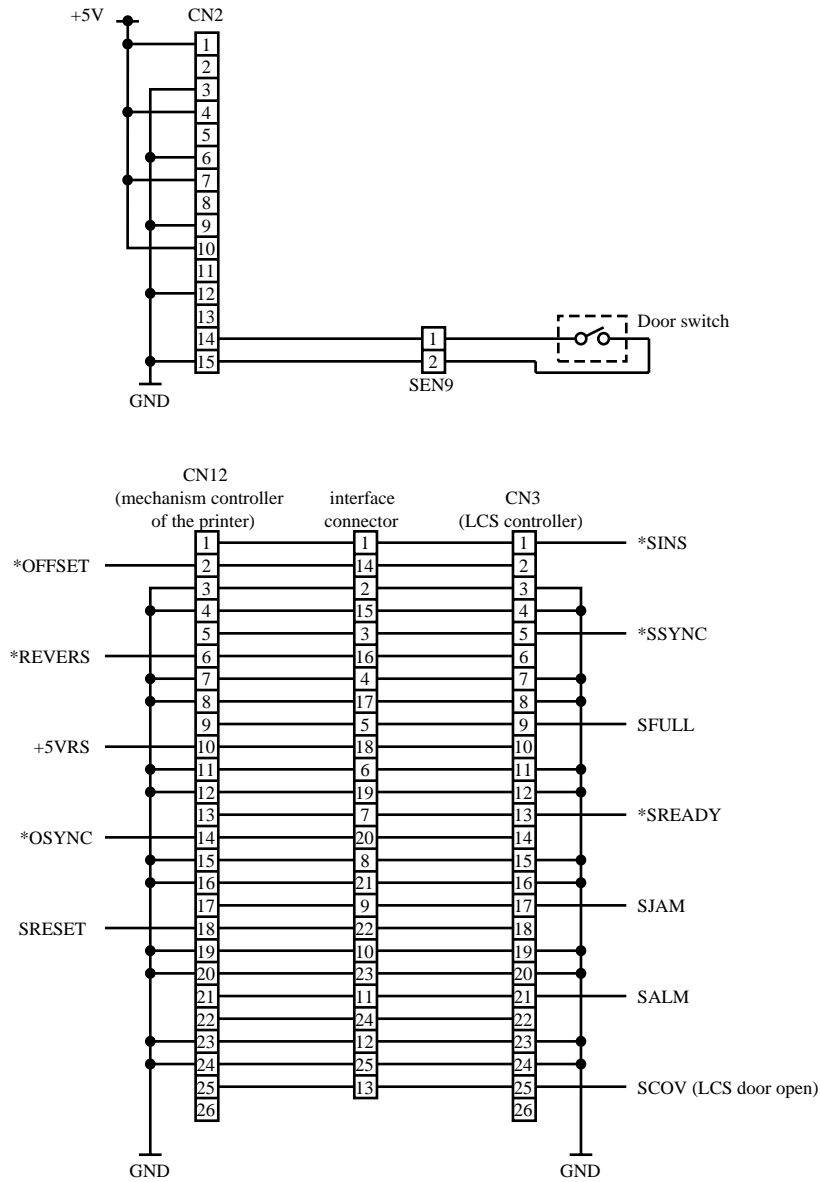

Figure 5-6. LCS Door Open Related Problems Interconnections Diagram (2 of 2)

5-10.3. LCS Stacker Tray Continuous Up-Down Travel

Explanation

The paper tray moves up and down reciprocally.

Troubleshooting Procedure

<010> Once turn off the locker switch of the LCS, open the front door, and set the dip switch on the LED unit PCB "0100", then close the front door and turn on the locker switch again. (Confirm the printer is turned on and the front door of the LCS is closed. The change of the dip switch is recognized by the LCS controller when the locker switch is turned on.)

<020> Check the top sensor by putting a piece of paper facing the top sensor and remove it, while seeing the LED8 (green LED) on the LED unit PCB. Does the LED turn on and off corresponding the top sensor? <Y:100, N:030>

<030> Replace the LCS controller PCB.

<040> Exit.

<100> Check damages or pinches of wire, cable and connector between the following connectors:

CN4 on the LCS controller PCB and CN16 on the harness,

CN16 on the harness and SEN6 at the top sensor.

<110> Does this problem still occur? <Y:120, N:Exit>

<120> Replace the top sensor.

<130> Does this problem still occur? <Y:030, N:Exit>

NOTE

When you check whether the problem still occur or exit the troubleshooting flow, do not forget to set the dip switch as it was "0000".

Reference Diagrams

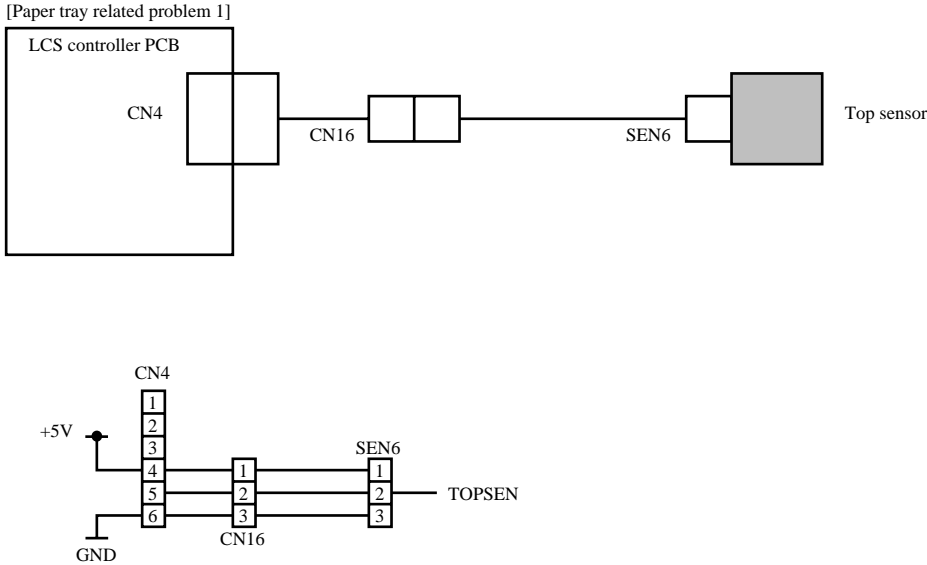

Figure 5-7. LCS Stacker Tray Continuous Up-Down Travel Interconnections Diagram

5-10.4. LCOS Stacker Tray Stays Down**Explanation**

The paper tray does not move up after the stacked paper was removed.

Troubleshooting Procedure

<010> Once turn off the locker switch of the LCS, open the front door, and set the dip switch on the LED unit PCB "0100", then close the front door and turn on the locker switch again. (Confirm the printer is turned on and the front door of the LCS is closed. The change of the dip switch is recognized when the locker switch is turned on by the LCS controller.)

<020> Check the top sensor by putting a piece of paper facing the top sensor and remove it, while seeing the LED8 (green LED) on the LED unit PCB. Does the LED turn on and off corresponding the top sensor? <Y:100, N:030>

<030> Replace the LCS controller PCB.

<040> Exit.

<100> Check damages or pinches of wire, cable and connector between the following connectors:

CN4 on the LCS controller PCB and CN16 on the harness,

CN16 on the harness and SEN6 at the top sensor.

<110> Does this problem still occur? <Y:120, N:Exit>

<120> Replace the top sensor.

<130> Does this problem still occur? <Y:030, N:Exit>

NOTE

When you check whether the problem still occur or exit the troubleshooting flow, do not forget to set the dip switch as it was "0000".

Reference Diagrams

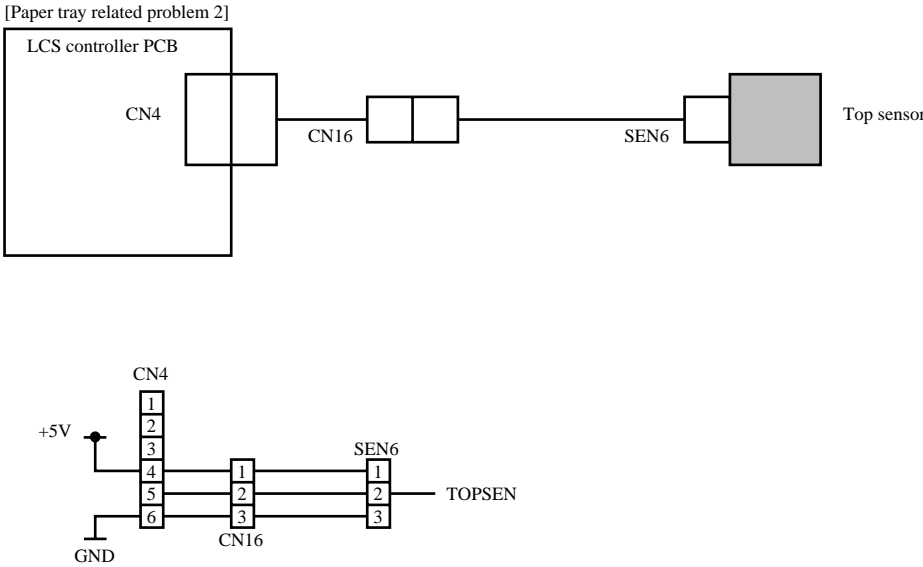

Figure 5-8. LCS Stacker Tray Stays Down Interconnections Diagram

5-10.5. LCS Not Sensed By Printer

Explanation

The printer does not sense the installed LCS.

Troubleshooting Procedure

<010> Is the interface cable connected to the printer correctly? <Y:020, N:012>

<012> Connect the cable correctly.

<014> Does this problem still occur? <Y:020, N:Exit>

<020> Check damages or pinches of wire, cable, and connector between the following connectors:

CN12 on the mechanism controller PCB of the printer (especially for pin1) and the LCS interface connector,

LCS interface connector and CN3 on the LCS controller PCB (especially for pin1).

<022> Does this problem still occur? <Y:030, N:Exit>

<030> Replace the LCS controller PCB.

Reference Diagrams

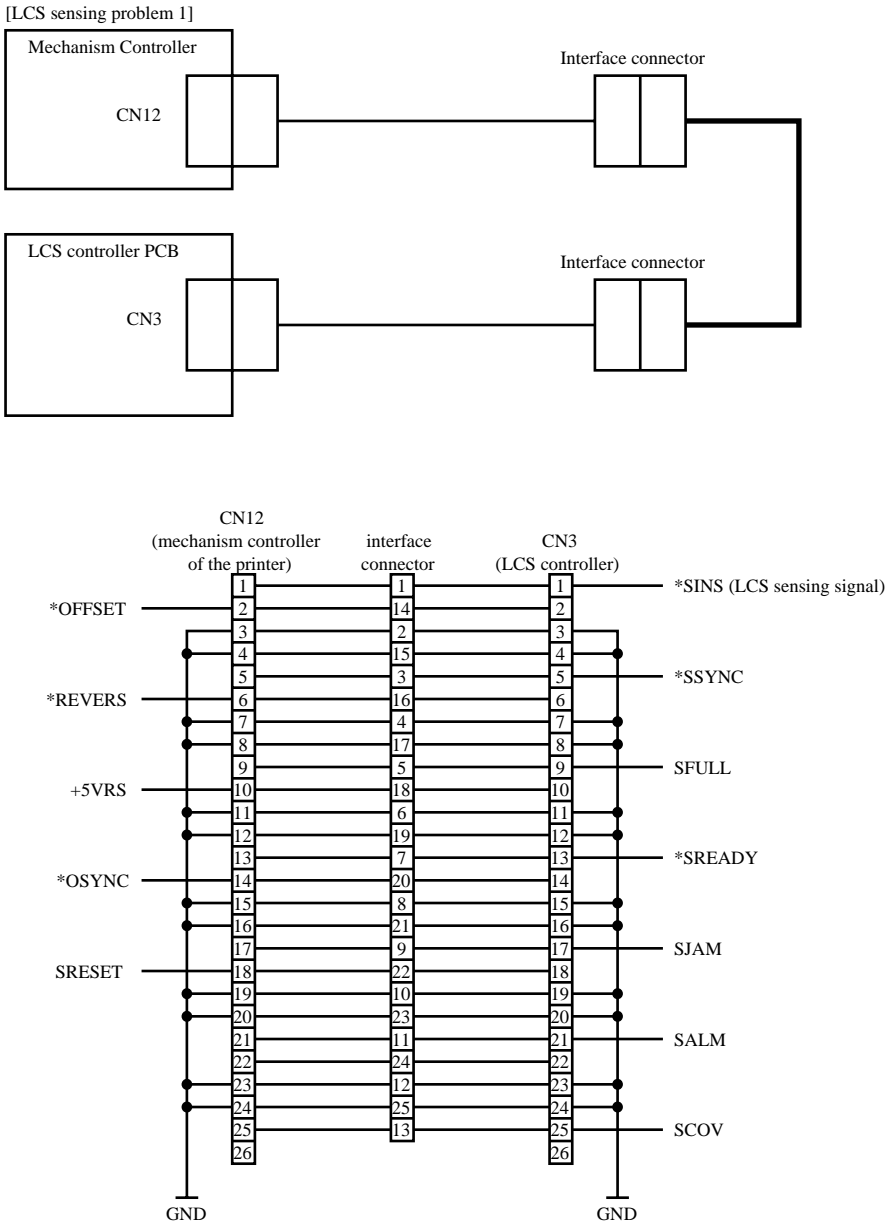

Figure 5-9. LCS Not Sensed By Printer Interconnections Diagram

5-10.6. LCS Not Installed But Sensed By Printer

Explanation

The printer senses the LCS although it is not installed.

Troubleshooting Procedure

<010> Check damages or pinches of wire, cable, and connector between the following connectors:

CN12 on the mechanism controller PCB of the printer (especially for pin1) and LCS interface connector.

<012> Does this problem still occur? <Y:020, N:Exit>

<020> Replace the mechanism controller PCB (CA02626-J001, see 4-48, fig.4-2).

Reference Diagrams

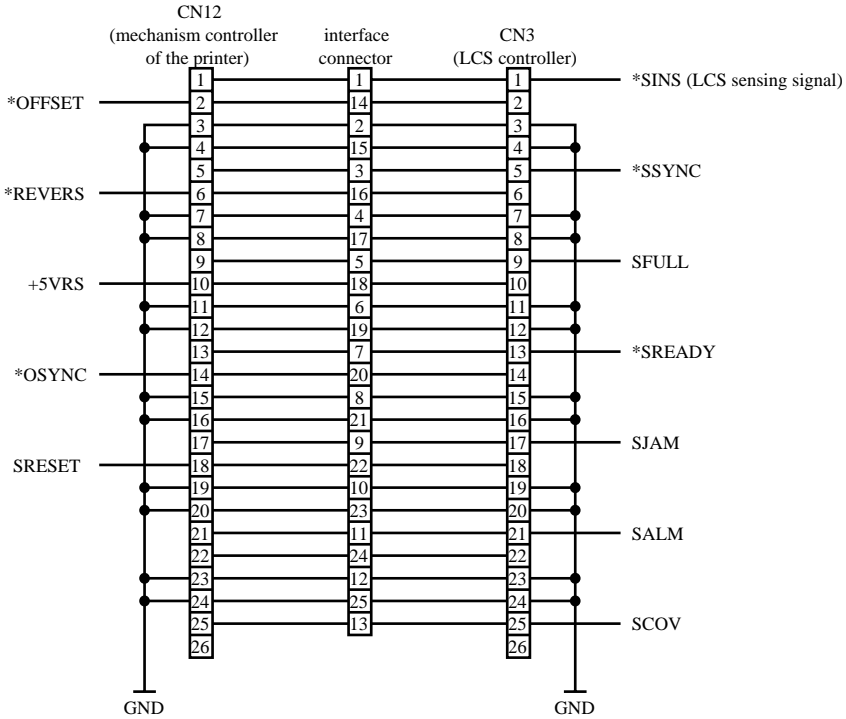
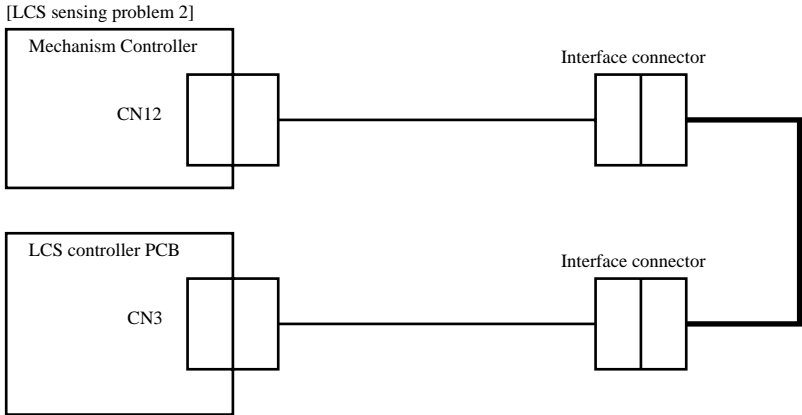

Figure 5-10. LCS Not Installed But Sensed By Printer Interconnections Diagram

CHAPTER 6 MAINTENANCE

Chapter 6 maintenance contents include:

Section

6-1	Introduction.....	6-3
6-2	Scope of Repair Procedures.....	6-3
6-3	Safety.....	6-3
6-4	Maintenance Parts Replacement Overview.....	6-3
	6-4.1 FRU Locational Views.....	6-4
	6-4.2 FRU Repair Procedure Locations.....	6-4
6-5	Adjustments.....	6-16
	6-5.1 +5V Power Supply Adjustment.....	6-16
	6-5.2 Laser Start Position Alignment.....	6-18
	6-5.3 Paper Feed System Alignment.....	6-21
6-6	Front of Printer Accessed FRUs.....	6-22
	6-6.1 Duplex Unit.....	6-22
	6-6.2 LED Erase Unit.....	6-25
	6-6.3 Operator Panel Board.....	6-29
	6-6.4 Transfer Assembly Guide.....	6-33
	6-6.5 Paper Tray Lift Motor.....	6-37
	6-6.6 Paper Size Sensor Board.....	6-39
6-7	Top of Printer Accessed FRUs.....	6-41
	6-7.1 Main Controller Board.....	6-41
	6-7.2 Optical Unit.....	6-45
6-8	Rear of Printer Accessed FRUs.....	6-49
	6-8.1 Drive Unit D Motor Assembly.....	6-49
	6-8.2 Mechanism Controller Board.....	6-51
	6-8.3 Registration Roller Standby Clutch.....	6-55
	6-8.4 High Voltage Power Supply.....	6-57
	6-8.5 Low Voltage Power Supply.....	6-59
	6-8.6 Low Voltage Power Supply Fan.....	6-63
	6-8.7 Power Sequencing Relay.....	6-65
	6-8.8 Drive Unit M.....	6-67
	6-8.9 Drive Unit M Lower Fan.....	6-77
	6-8.10 Drive Unit M Waste Toner Screw Sensor.....	6-79
	6-8.11 Drive Unit M Fuser Interlock Switch (TINTSW).....	6-83
	6-8.12 Drive Unit E to Ejection Unit Belt.....	6-87
	6-8.13 Drive Unit E Gear Assembly.....	6-89
	6-8.14 PS5 - Duplex Unit Paper Path Sensor.....	6-93
	6-8.15 PS7 - Ejection Unit Paper Path Sensor.....	6-95

SERVICE MANUAL

	6-8.16 Ejection Tray - Paper Path Stacker Full Sensor	6-97
6-9	Left Side of Printer Accessed FRUs.....	6-99
	6-9.1 Ejection Unit.....	6-99
	6-9.2 Reversing Unit.....	6-101
	6-9.3 PS6 - Reversing Unit Paper Path Sensor.....	6-103
6-10	Right Side of Printer Accessed FRUs	6-105
	6-10.1 Toner Hopper Assembly.....	6-105
	6-10.2 Input Power Circuit Breaker.....	6-109
	6-10.3 Developer Unit	6-111
	6-10.4 Paper Feed Unit	6-114
	6-10.5 PS1 - Paper Empty Sensors (PS1-1, -2, and -3)	6-118
	6-10.6 PS2 - Paper Path Timing Sensor	6-120
	6-10.7 PS3 - Paper Path Registration Sensor.....	6-122
	6-10.8 PS4 - Paper Path De-curling Sensor.....	6-124
	6-10.9 Paper Feed Unit Transport Feed Motor.....	6-128
	6-10.10 Registration Roller	6-132
6-11	Printer Microswitch Locational Diagrams	6-136
	6-11.1 Developer Unit Collector Bottle Detection Microswitch	6-136
	6-11.2 Developer Unit Shutter Detection Microswitch.....	6-137
	6-11.3 Drum Unit Interlock Microswitch.....	6-138
	6-11.4 Ejection Unit Cover Interlock Microswitch.....	6-139
	6-11.5 Front Door Interlock Microswitch.....	6-140
	6-11.6 Paper Tray Detection Microswitch.....	6-141
	6-11.7 Lower-right Cover Interlock Microswitch	6-142
	6-11.8 Upper-right Cover Interlock Microswitch.....	6-143

6-1. Introduction

This chapter identifies and provides the remove and replace procedures for the 4060 Cut Sheet Printer field replaceable units (FRU).

The procedures presented in this service manual assume the customer engineer has had some training on the 4060 Printer and is familiar with the mechanics of servicing the consumable supplies and opening the covers for access to the internal mechanisms.

6-2. Scope of Repair Procedures

The maintenance procedure presented in this service manual are for FRUs that require detailed maintenance instructions.

For FRUs that are easily maintained and where remove and replace procedures are common with other similar printer equipment, these instructions are not provided. *However, individual instructions and illustrations will be provided for these FRUs with the replacement FRU shipment.*

Instructions for removal and replacement of consumable supplies/assemblies are provide in the *4060 Printer User Manual*.

6-3. Safety

Always power the printer off when beginning FRU maintenance. Detach the power cord plug from the printer base to allow ease of access and for protection.

Where specified, allow at least 30 seconds for the electrical charges to drain before beginning your repair procedure.

6-4. Maintenance Parts Replacement Overview

Chapter 7 provides parts breakdown illustrations and part numbers. Use these illustrations for an in-depth look at the FRU you will be maintaining and/or handling to get at the failed FRU.

NOTE

The procedures presented in this chapter are mechanical repair procedures. To test the operation of the printer after the printer has been reassembled, return to the troubleshooting chapter for specific instructions.

6-4.1. FRU Locational Views

- | | |
|--------------------------------------|-----------|
| 1. Printer front and right side view | Page 6-5 |
| 2. Front inside view | Page 6-6 |
| 3. Top and upper-right side view | Page 6-7 |
| 4. Lower-right side view | Page 6-8 |
| 5. Rear and left-side view | Page 6-9 |
| 6. Rear inside view | Page 6-10 |
| 7. Printer rear and left side view | Page 6-9 |
| 8. Large-Capacity Hopper (LCH) view | Page 6-11 |
| 9. Large-Capacity Stacker (LCS) view | Page 6-12 |

6-4.2. FRU Repair Procedure Locations

- | | |
|-------------------------------------|-----------|
| 1. Front accessed FRUs listing | Page 6-13 |
| 2. Top accessed FRUs listing | Page 6-13 |
| 3. Rear accessed FRUs listing | Page 6-13 |
| 4. Left side accessed FRUs listing | Page 6-13 |
| 5. Right side accessed FRUs listing | Page 6-14 |
| 6. Microswitch references | Page 6-14 |
| 7. LCH FRUs listing | Page 6-15 |
| 8. LCS FRUs listing | Page 6-15 |

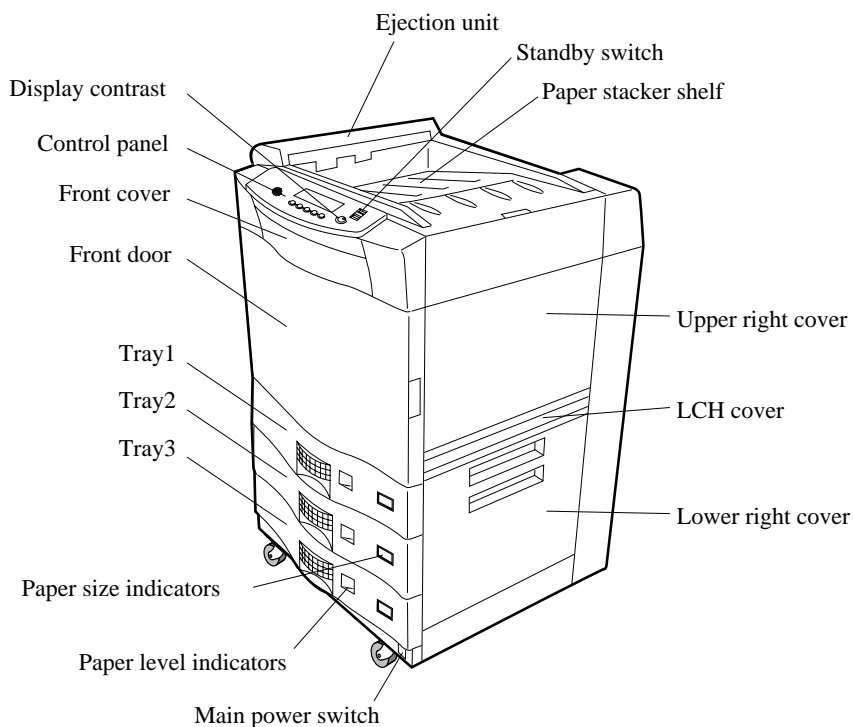
**Figure 6-1. Front and Right Side Reference Locations**

SERVICE MANUAL

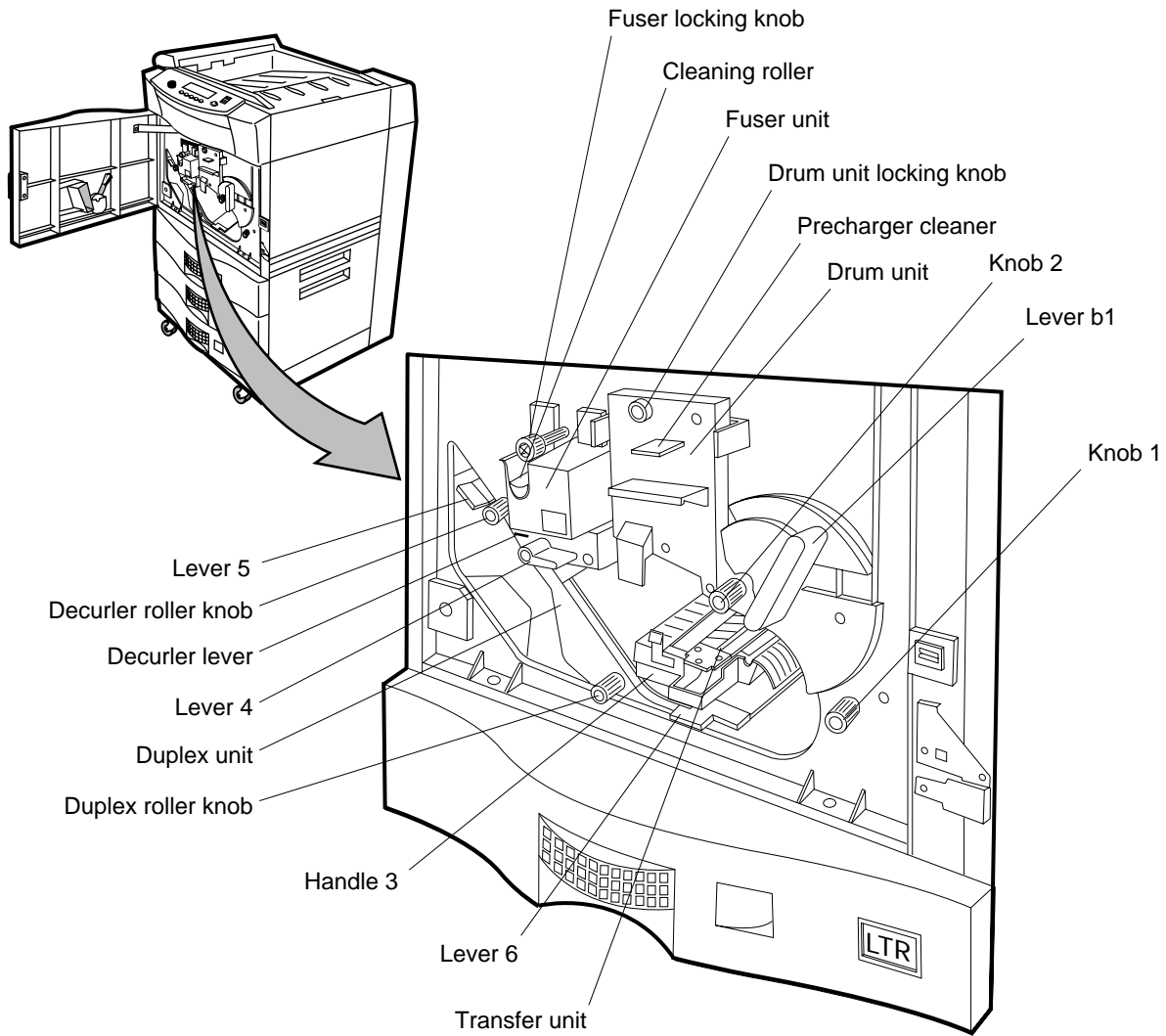

Figure 6-2. Front Inside Reference Locations

SERVICE MANUAL

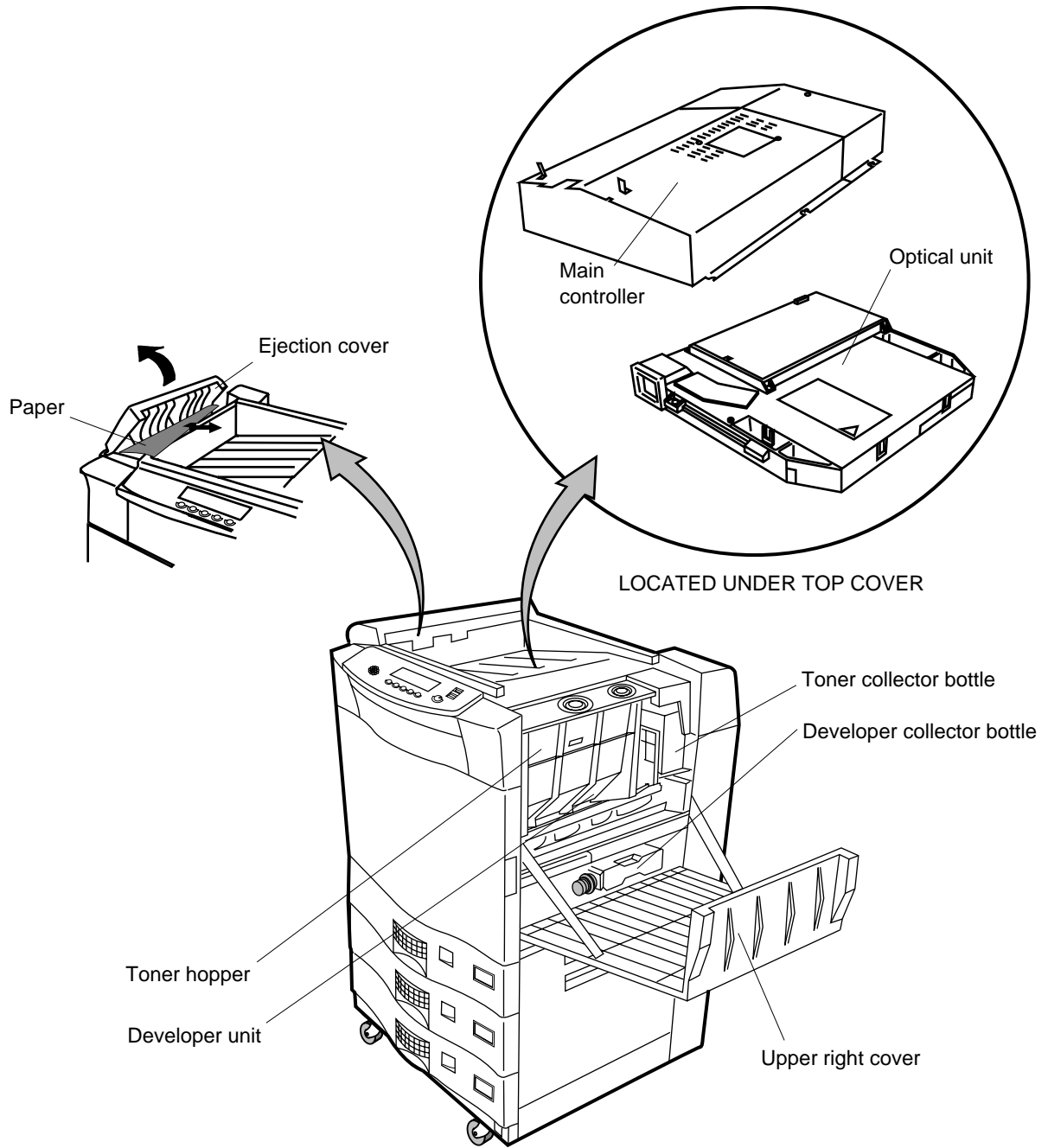

Figure 6-3. Top and Upper-Right Side Reference Locations

SERVICE MANUAL

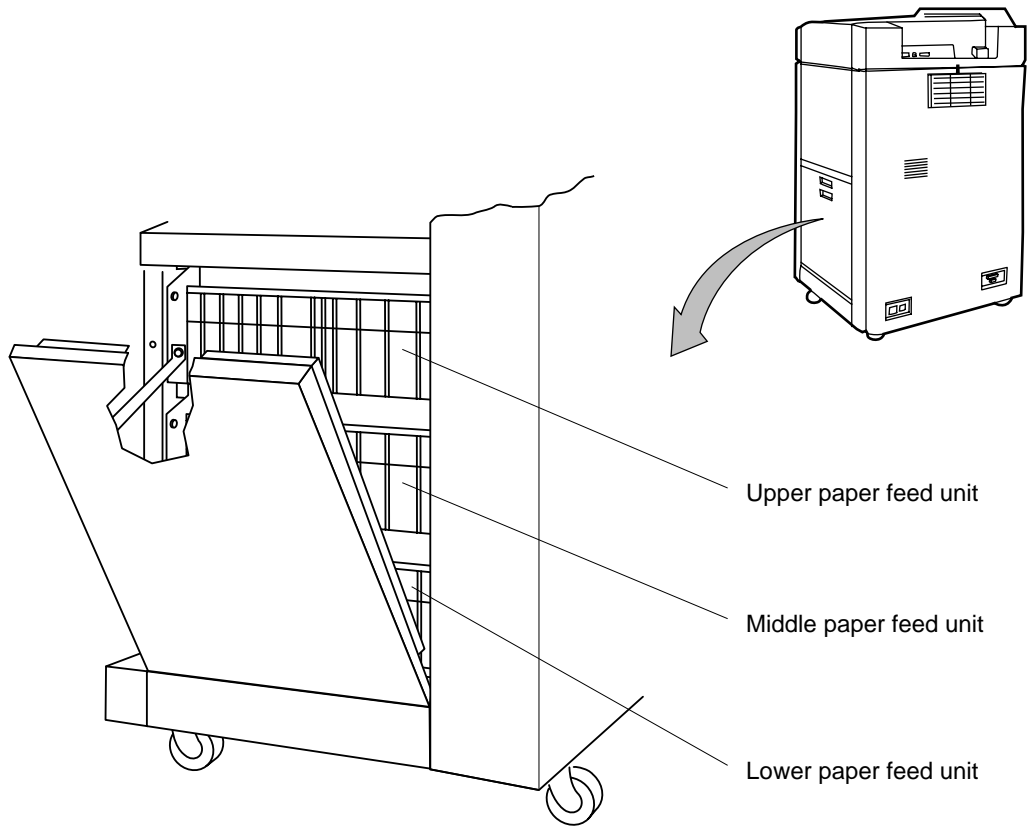

Figure 6-4. Lower-Right Side Reference Locations

SERVICE MANUAL

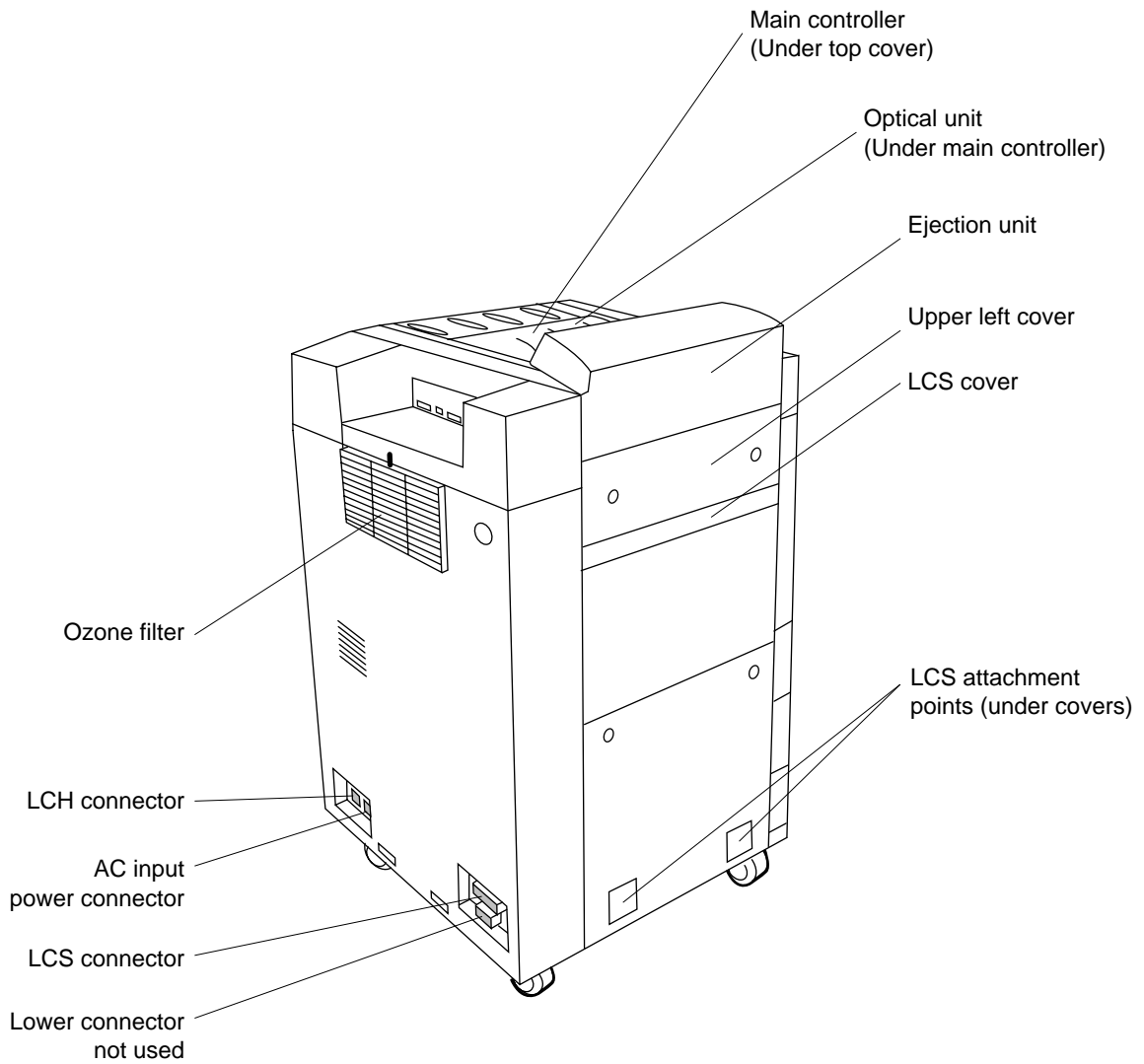

Figure 6-5. Rear and Left Side Reference Locations

SERVICE MANUAL

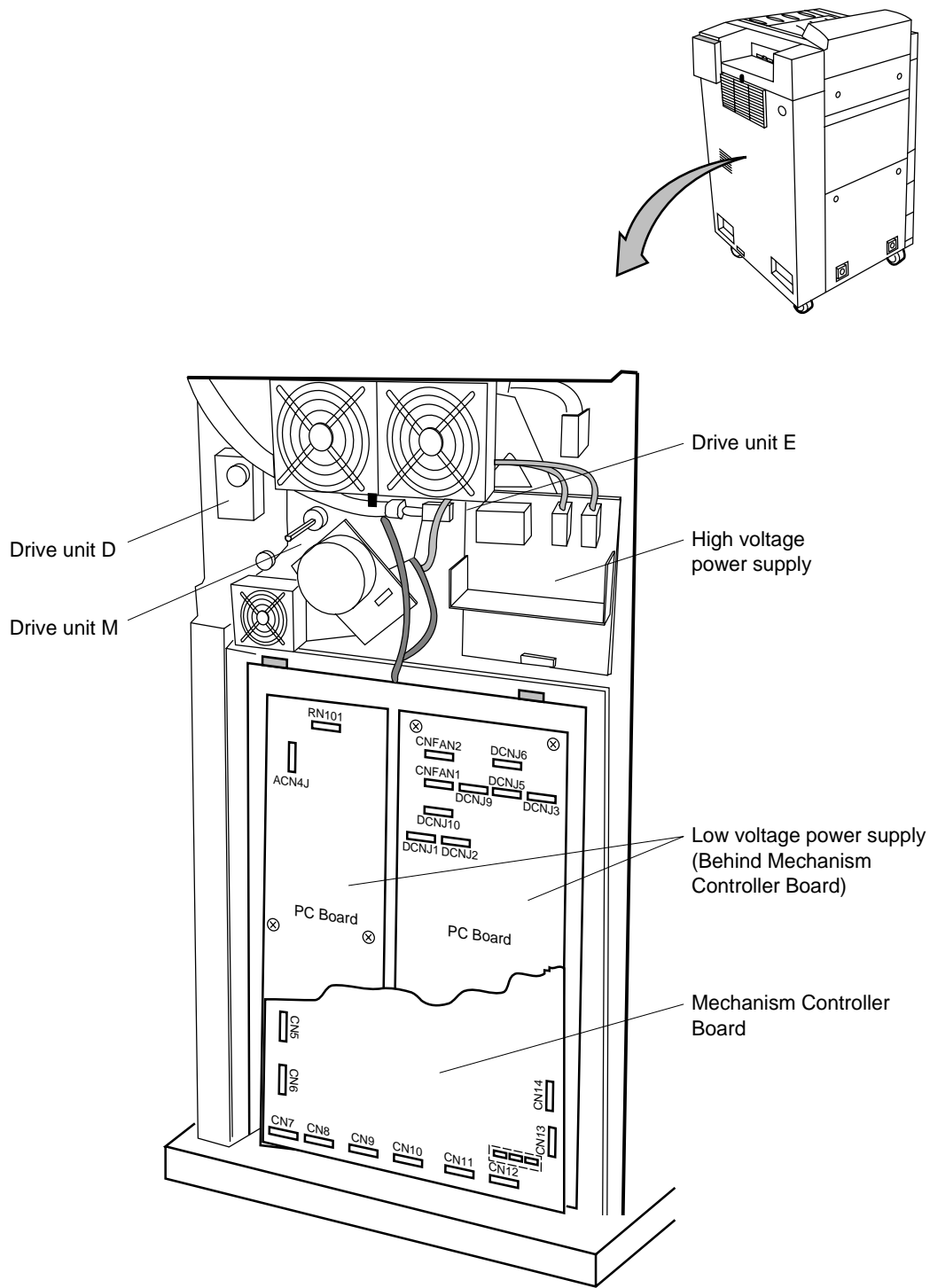

Figure 6-6. Rear Inside Reference Locations

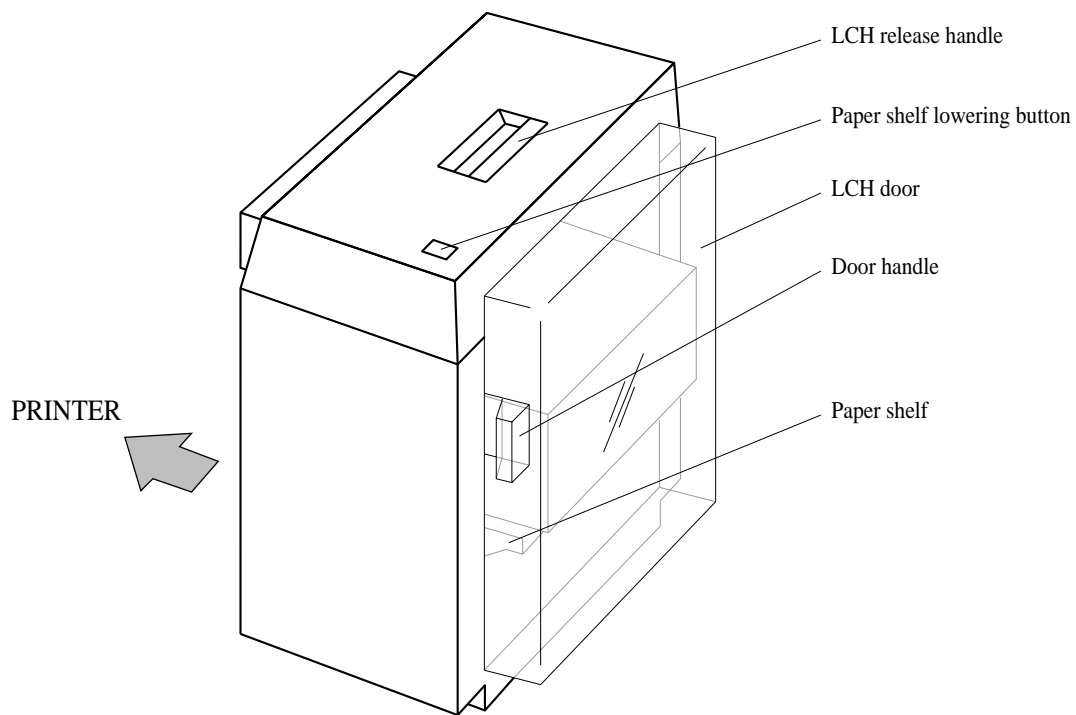

Figure 6-7. LCH Reference Locations

SERVICE MANUAL

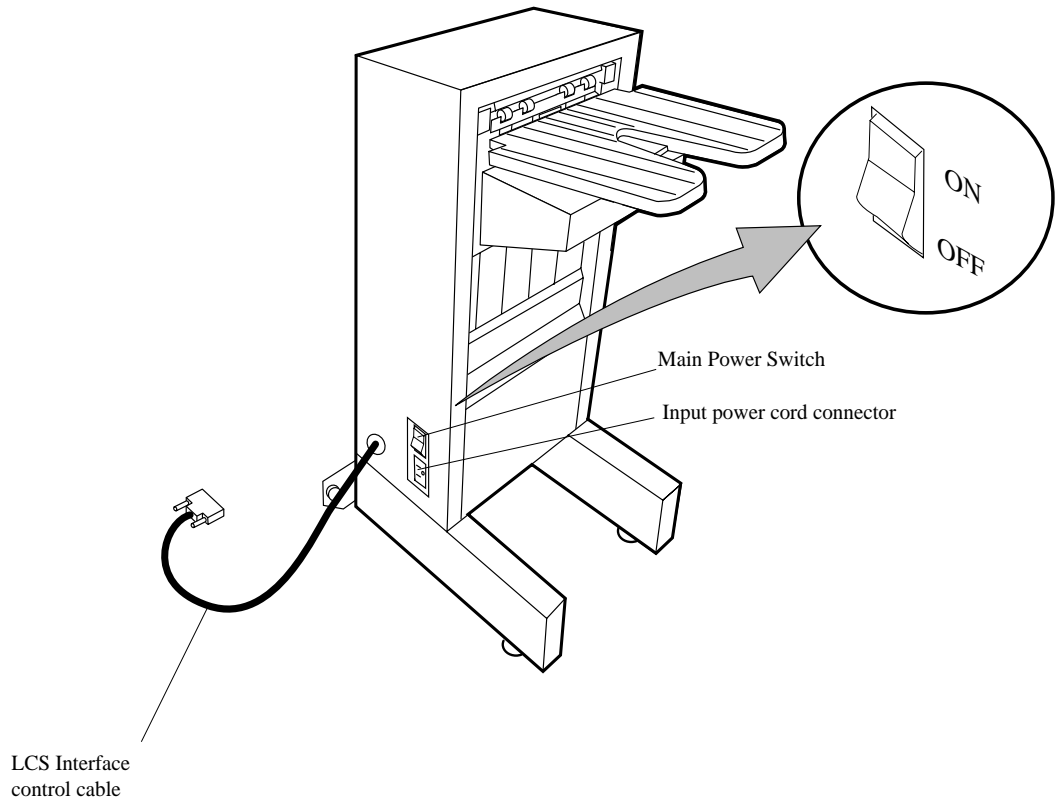

Figure 6-8. LCS Reference Locations

FRUs Accessed From Front of Printer

1. Duplex **Unit** Page 6-22
2. LED Erase **Unit** Page 6-25
3. Operator Panel **Board** Page 6-29
4. Transfer Assembly **Guide** Page 6-33
5. Paper Tray Lift **Motor** Page 6-37
6. Paper Size Sensor Board Page 6-39

FRUs Accessed From Top of Printer

1. QMS Main Controller **Board** Page 6-42
2. Optical **Unit** Page 6-46

FRUs Accessed From Rear of Printer

1. Drive Unit D Motor **Assembly** Page 6-50
2. Mechanism Controller **Board** Page 6-51
3. Registration Roller Standby **Clutch** Page 6-55
4. High Voltage **Power Supply** Page 6-57
5. Low Voltage **Power Supply** Page 6-59
6. Low Voltage Power Supply **Fan** Page 6-63
7. Power Sequencing **Relay** Page 6-65
8. Drive **Unit M** Page 6-67
9. Drive Unit M Lower **Fan** Page 6-78
10. Drive Unit M Toner Waste Screw **Sensor** Page 6-80
11. Fuser Interlock (TINTSW) **Switch** Page 6-84
12. Drive Unit E to Ejection Unit **Belt** Page 6-88
13. Drive Unit E Gear **Assembly** Page 6-90

SERVICE MANUAL

- | | |
|---|-----------|
| 14. PS5 - Duplex Unit Paper Path Sensor | Page 6-94 |
| 15. PS7 - Ejection Unit Paper Path Sensor | Page 6-96 |
| 16. Ejection Unit Stacker Full Paper Path Sensor | Page 6-98 |

FRUs Accessed From Left Side of Printer

- | | |
|--|------------|
| 1. Ejection Unit | Page 6-100 |
| 2. Reversing Unit | Page 6-103 |
| 3. PS6 - Reversing Unit Paper Path Sensor | Page 6-105 |

FRUs Accessed From Right Side of Printer

- | | |
|---|------------|
| 1. Toner Hopper Assembly | Page 6-106 |
| 2. Input Power Circuit Breaker | Page 6-109 |
| 3. Developer Unit | Page 6-111 |
| 4. Paper Feed Unit | Page 6-114 |
| 5. PS1 - Paper Empty (PS1-1, -2, -3) Sensors | Page 6-118 |
| 6. PS2 - Paper Path Timing Sensor | Page 6-120 |
| 7. PS3 - Paper Path Registration Sensor | Page 6-122 |
| 8. PS4 - Paper Path De-curler Sensor | Page 6-124 |
| 9. Paper Feed Unit Transport Feed Motor | Page 6-128 |
| 10. Registration Roller | Page 6-132 |

Location Diagrams Only for Microswitch FRUs

- | | |
|--|------------|
| 1. Developer Bottle Detection Microswitch | Page 6-136 |
| 2. Developer Unit Shutter Detection Microswitch | Page 6-136 |
| 3. Drum Interlock Microswitch | Page 6-138 |
| 4. Ejection Unit Cover Interlock Microswitch | Page 6-139 |
| 5. Front Door Interlock Microswitch | Page 6-140 |

- | | |
|---|------------|
| 6. Paper Tray Detection Microswitch | Page 6-141 |
| 7. Lower-right Cover Interlock Microswitch | Page 6-142 |
| 8. Upper-right Cover Interlock Microswitch | Page 6-143 |

LCHF FRUs

- | | |
|------------------------------------|-----------------|
| 1. Frame Assembly | To be developed |
| 2. Paper Transport Assembly | To be developed |

LCS FRUs

- | | |
|------------------------------------|-----------------|
| 1. Frame Assembly | To be developed |
| 2. Paper Transport Assembly | To be developed |

6-5. Adjustments

Unscheduled adjustments may be required in the 4060 printer, LCH, and the LCS. Typically, they become necessary during maintenance to the FRU components but adjustments can be required at any time. The adjustments are:

- Procedure 6-5.1 "+5V Power Supply Adjustment," Page 6-16
- Procedure 6-5.2 "Laser Start Position Alignment," Page 6-18
- Procedure 6-5.3 "Paper Feed System Alignment," Page 6-20

6-5.1. +5V Power Supply Adjustment

NOTE

This procedure is **not** user accessible.

These +5V power adjustment (actually +4.82V) steps are:

- | | | |
|----|---|---|
| 1. | Remove rear cover | |
| 2. | Using your multimeter, monitor test point +5V W7 on the mechanism controller PCB | Figure 6-9 illustrates the +5V (W7) test point location |
| 3. | Verify voltage is +4.82 +/-0.02V | +4.80V to +4.84V |
| 4. | Use small flat-blade screwdriver to adjust potentiometer RV113 | Figure 6-9 illustrates the access of the +5V Adjustment through the top hole of the mechanism controller PCB supporting bracket |
| 5. | If voltage level cannot be maintained, use troubleshooting flow charts SVC59 and SVC5A to fault isolate | Go to chapter 5 for SVC59 and SVC5A troubleshooting flow charts |
| 6. | If LVPS output is set properly, close rear cover | |

SERVICE MANUAL

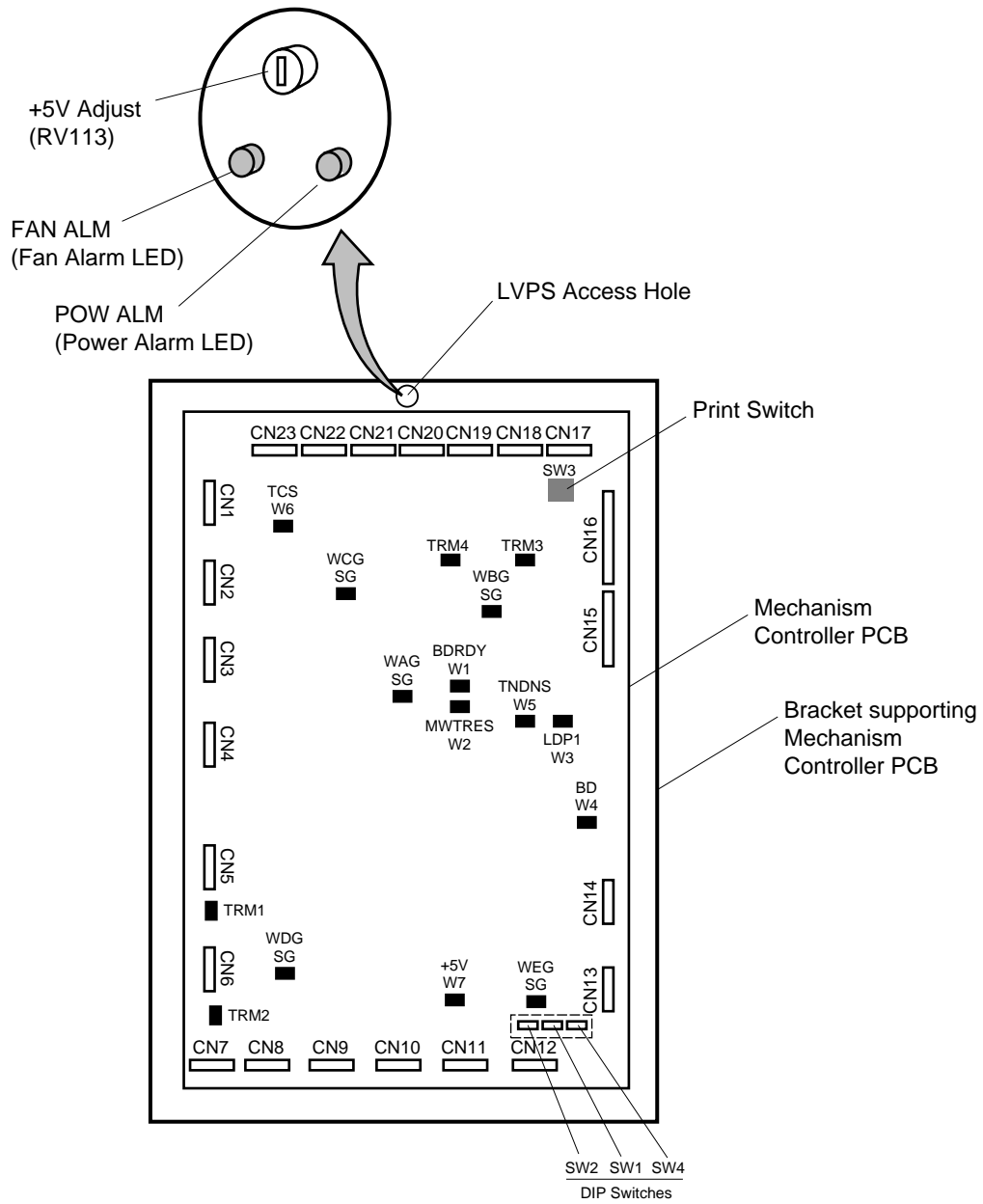

Figure 6-9. LVPS +5V Test Point W7, +5V Adjustment, and SW2 DIP Switch Locations

6-5.2. Laser Start Position Alignment

NOTE

The actual detail of this procedure depends on the functionality of the main controller and software installed. This procedure is user accessible.

Periodic registration alignment checking by the customer may indicate fine tuning is required as the registration roller or some other component ages.

This laser start position alignment procedure establishes the baseline for the leading edge *print- no print* border.

Test setup and analysis:

- | | | |
|----|---|---|
| 1. | Verify that letter or A4 size paper is in all paper trays | Paper tray 1, 2, 3, and LCH (if installed) |
| 2. | On operator panel, select and print the alignment program | |
| 3. | To align: | |
| a. | Read the test pattern printed instructions that describe SW2 DIP switch settings | Note - the switch settings are provided following this procedure |
| b. | Raise the test print up to a strong light so you can see the horizontal bar through the paper | The ideal test pattern is to have the horizontal bar exactly through the center under arrow head |
| c. | If you are within +/-0.5 mm of the ideal pattern, you are done
Go to step 5 | |
| | If you must realign, continue: | |
| d. | Set SW2 DIP switches S1-S4 to 1 1 1 0 | S1-S4 (left to right) |
| e. | Generate a new test pattern | Repeat steps 2a through 2h |
| e. | Determine SW2 correction setting | The horizontal line will touch one of the lines leading to the new SW2 setting |
| f. | Set SW2 DIP switches S1-S4 to the new setting | |
| g. | Generate a new test pattern | Repeat steps 2a through 2h |
| h. | If you are within +/-0.5 mm of the ideal pattern, you are done
Go to step 5 | |
| | If you must fine tune,
go back to step 4d | |
| 4. | Close all covers | |

5. Examine the 3 corner box patterns for alignment
- a. If the patterns are reasonably aligned, you are done

SW2 DIP Switches Reference

Locate SW2 DIP switch on mechanism controller

Figure 6-9 locates SW2 DIP switch at lower right corner

To get the required test pattern alignment, set SW2 (S1-S4) in the following pattern

S1-S4 (left to right)

If you want to **increase** spacing above the line, use the + distance settings

Adjustment Distance	S1	S2	S3	S4
-7.40 mm	0	0	0	0
-6.34 mm	1	0	0	0
-5.29 mm	0	1	0	0
-4.23 mm	1	1	0	0
-3.17 mm	0	0	1	0
-2.11 mm	1	0	1	0
-1.06 mm	0	1	1	0
0 mm	1	1	1	0
+1.06 mm	0	0	0	1
+2.11 mm	1	0	0	1
+3.17 mm	0	1	0	1
+4.23 mm	1	1	0	1
+5.29 mm	0	0	1	1
+6.34 mm	1	0	1	1
+7.40 mm	0	1	1	1
+8.46 mm	1	1	1	1

1 = ON (up)
0 = OFF (down)

0 mm is default

- b. If alignment is required
go to *Paper Feed System Alignment*
Page 6-20

6-5.3. Paper Feed System Alignment

NOTE

The actual detail of this procedure depends on the functionality of the main controller and software installed. This procedure is user accessible, if available.

SERVICE MANUAL

SERVICE MANUAL

6-6. Front of Printer Accessed FRUs

6-6.1. Duplex Unit

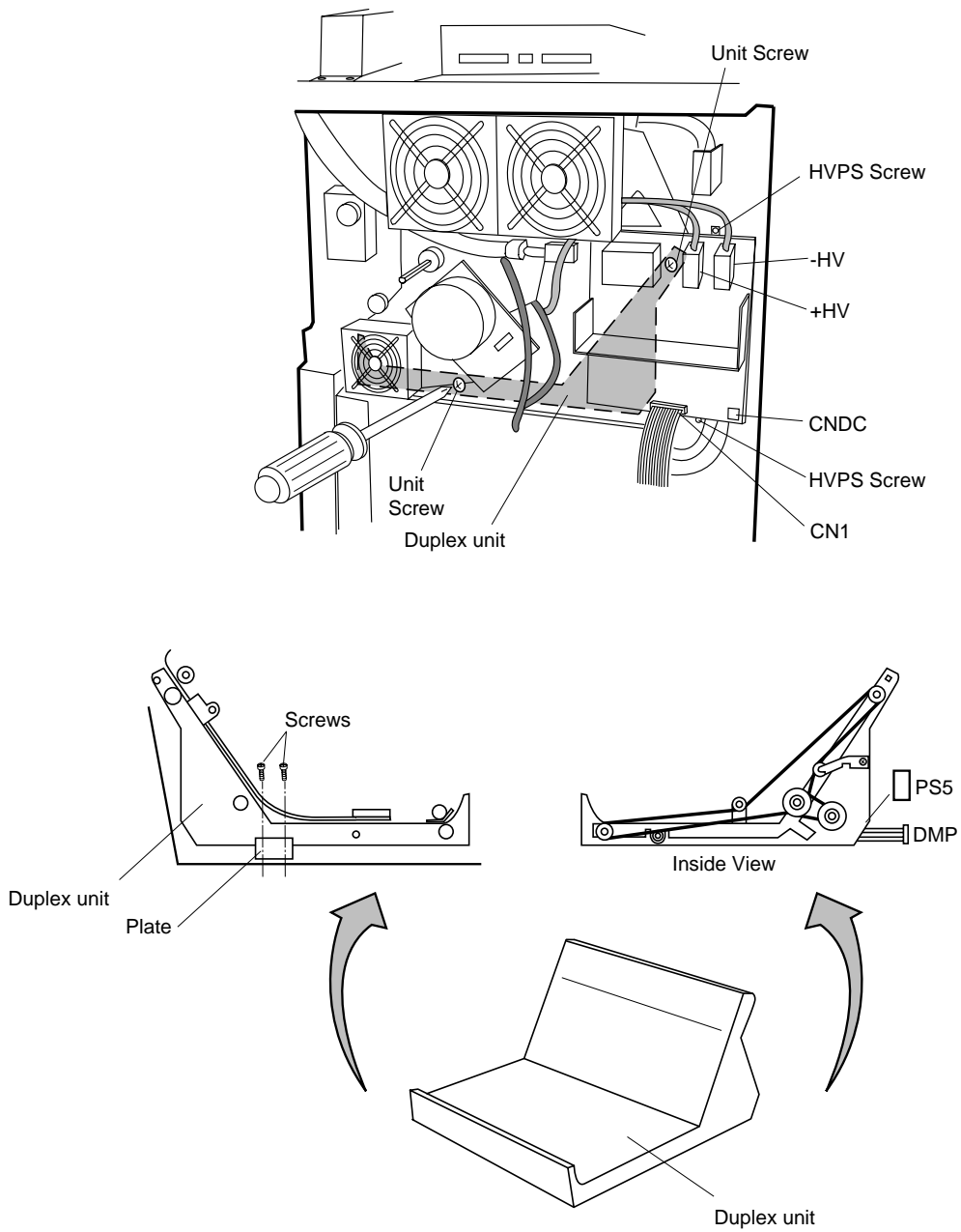

Figure 6-10. Duplex Unit

Duplex Unit Replacement Procedure

Part Number

CA02626-E840

Tools Required

Magnetized 8-inch, number-2 Phillips-head screwdriver

Replacement Procedure (removal)

Step	Instruction	Comment
1.	Open upper-right cover	
2.	Open front door	
3.	Remove back cover	
4.	Remove the fuser	
5.	On HVPS board, disconnect CNDC connector	Lower right corner
6.	Disconnect CN1 connector	Ribbon cable
7.	Remove 2 HVPS bracket screws and swing open the HVPS assembly	Secures bracket to frame
8.	Remove 2 screws securing the duplex unit to the frame	
9.	Disconnect 2 duplex unit connectors (PS5 and DMP)	Facing printer left side
10.	At front, remove 2 screws and a plate	
11.	Pull duplex unit out	

Replacement Procedure (mounting)

1. Slide new unit into place
2. Reattach a plate and 2 screws
3. At rear, reconnect PS5 and DMP connectors
4. Secure 2 duplex unit screws
5. Close HVPS assembly and secure 2 bracket screws
6. Reconnect CN1 and CNDC connectors

SERVICE MANUAL

7. Install fuser
8. Close all covers

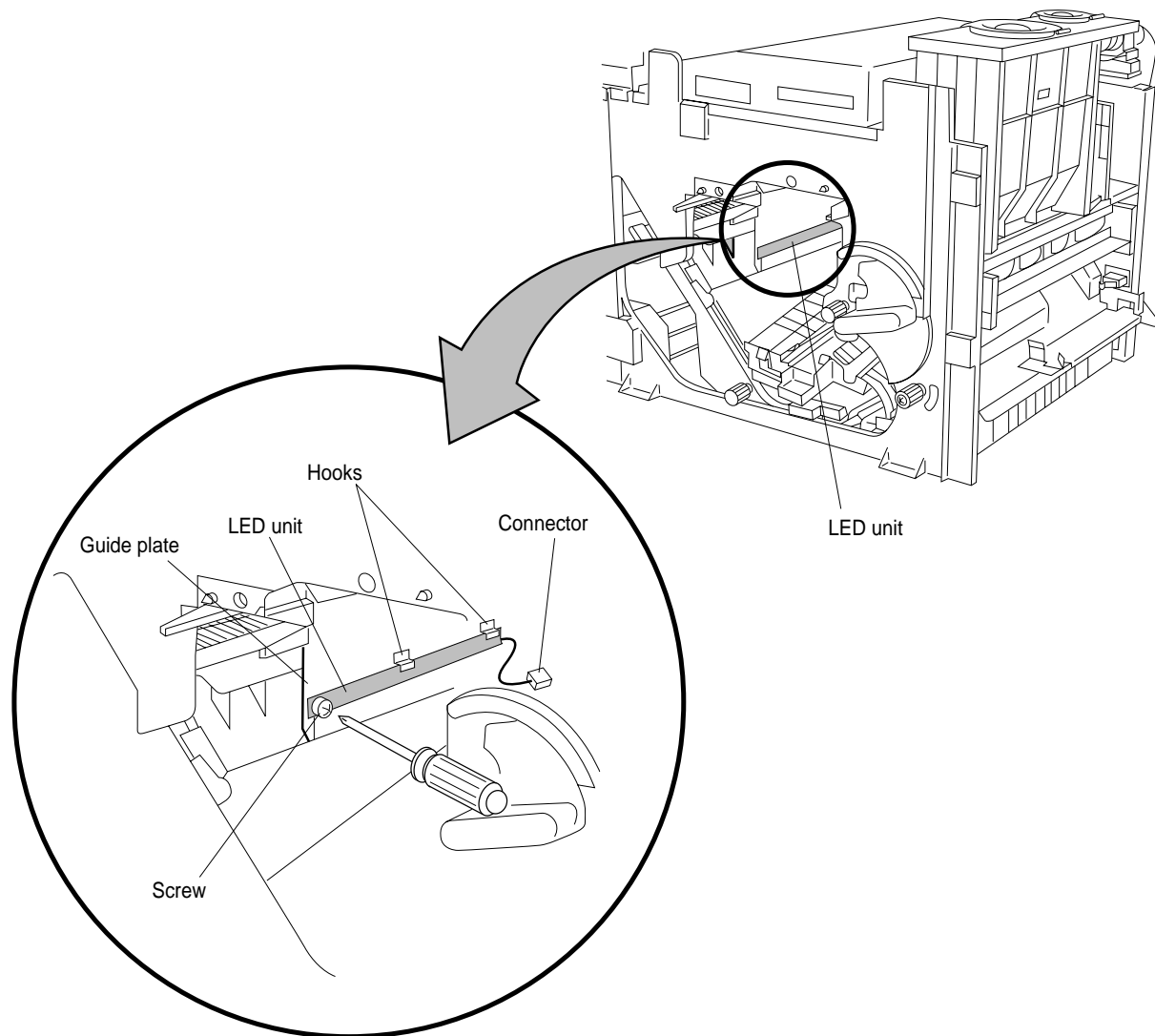
6-6.2. LED Erase Unit**Figure 6-11. LED Erase Unit**

SERVICE MANUAL

LED Erase Unit Replacement Procedure

Part Number

CA55002-0339

Tools Required

Magnetized 8-inch, number-2 Phillips-head screwdriver

Magnetized number 2-inch (stubby), Phillips-head screwdriver

Replacement Procedure (removal)

Step	Instruction	Comment
1.	Open right cover	
2.	Open front door	
3.	Remove back cover	
4.	CAUTION May be HOT	
	Pull fuser unit out and set aside in safe area	
5.	Lower transfer guide assembly	
6.	Remove the drum unit	
7.	At back of printer, disconnect inline snap connector CLEDP	Cable passes through access hole
8.	Open cable clamp free cable from clamp and pass connector back into printer	
9.	At front of printer, locate LED erase unit mounting screw on guide plate	Look inside above LEDs
10.	Use magnetized "stubby" Phillips-head screwdriver to remove 1 mounting screw	Mounting hooks secure the guide plate in place
11.	Remove 1 screw and LED cover	
12.	Carefully pull LED erase unit and cable connector free of printer frame hooks	

Replacement Procedure (mounting)

1. Replace the LED erase unit and LED cover:

- a. Pass cable and connector through cable hole
- b. **CAUTION**
Do not crimp LED erase unit cable under guide plate
Hang the guide plate on hooks to secure
- c. Secure the guide plate screw
2. At the rear, secure the cable in the clamp
3. Reconnect inline connector CLED
4. Install the drum unit
5. Install the fuser unit
6. Close all covers

SERVICE MANUAL

6-6.3. Operator Panel Board

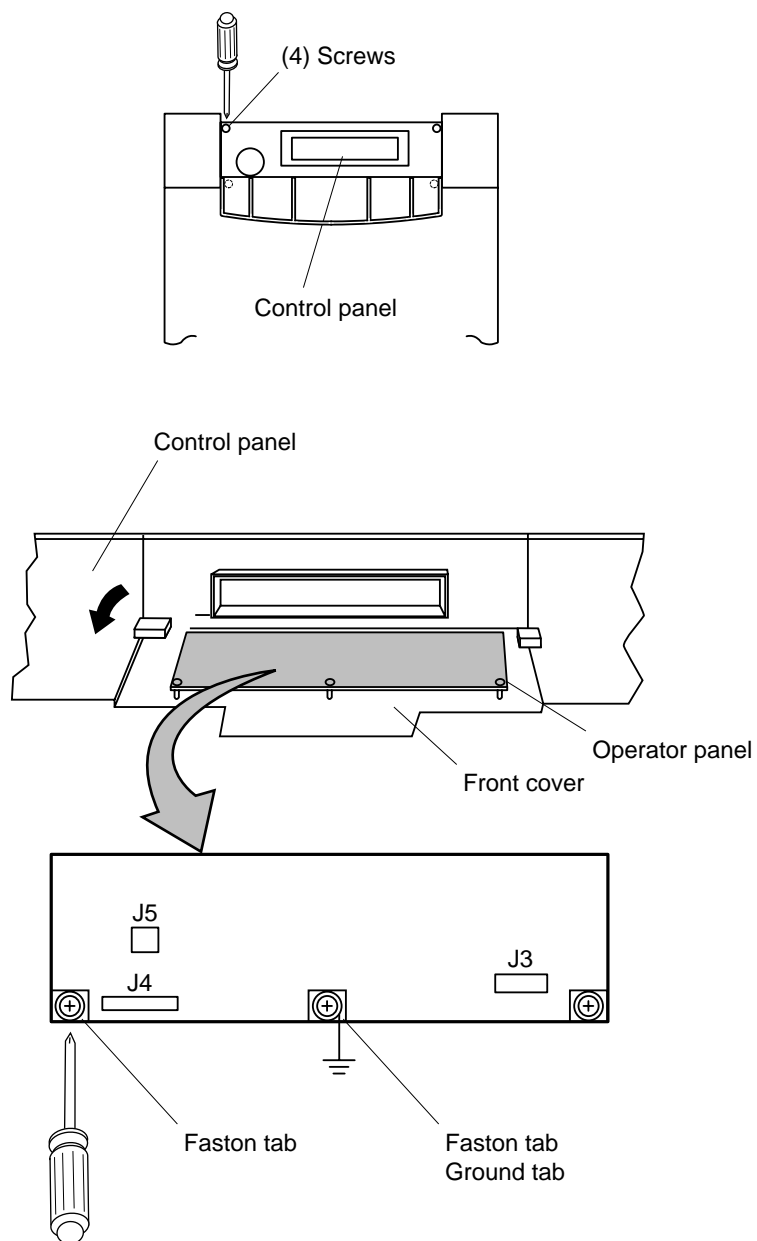

Figure 6-12. Operator Panel Board

SERVICE MANUAL

Operator Panel Board Replacement Procedure

Part Number

CA31214-C026

Tools Required

Magnetized 8-inch, number-2 Phillips-head screwdriver

Replacement Procedure (removal)

Step	Instruction	Comment
1.	Open right cover	
2.	Remove top cover	
3.	Open front operator panel and remove 4 panel holding screws	
4.	Disconnect 3 faston grounding connections from main controller box	Remove the operator panel assembly to a flat work surface
5.	Disconnect J3, J4, and J5 connectors	NOTES - 1. Lift panel and rotate up to access panel connections 2. Connector J4 has a protective plastic strip securing the squeeze tabs. Rotate strip to allow removal.
6.	Remove operator panel cover	
7.	Remove 3 screws	The 3rd wire is connected to switch
8.	Remove operator board	

Replacement Procedure (mounting)

1.	Install new operator board	
2.	Reattach panel board and 2 ground wires with 3 screws	
3.	At printer, attach 3 ground wires faston terminals to main controller	
4.	Attach J3, J4, and J5	Reposition protective strip to secure plug
5.	Remount operator panel assembly using side hooks on the panel	
6.	Reattach 4 panel screws	
7.	Close all covers	

SERVICE MANUAL

SERVICE MANUAL

6-6.4. Transfer Assembly Guide

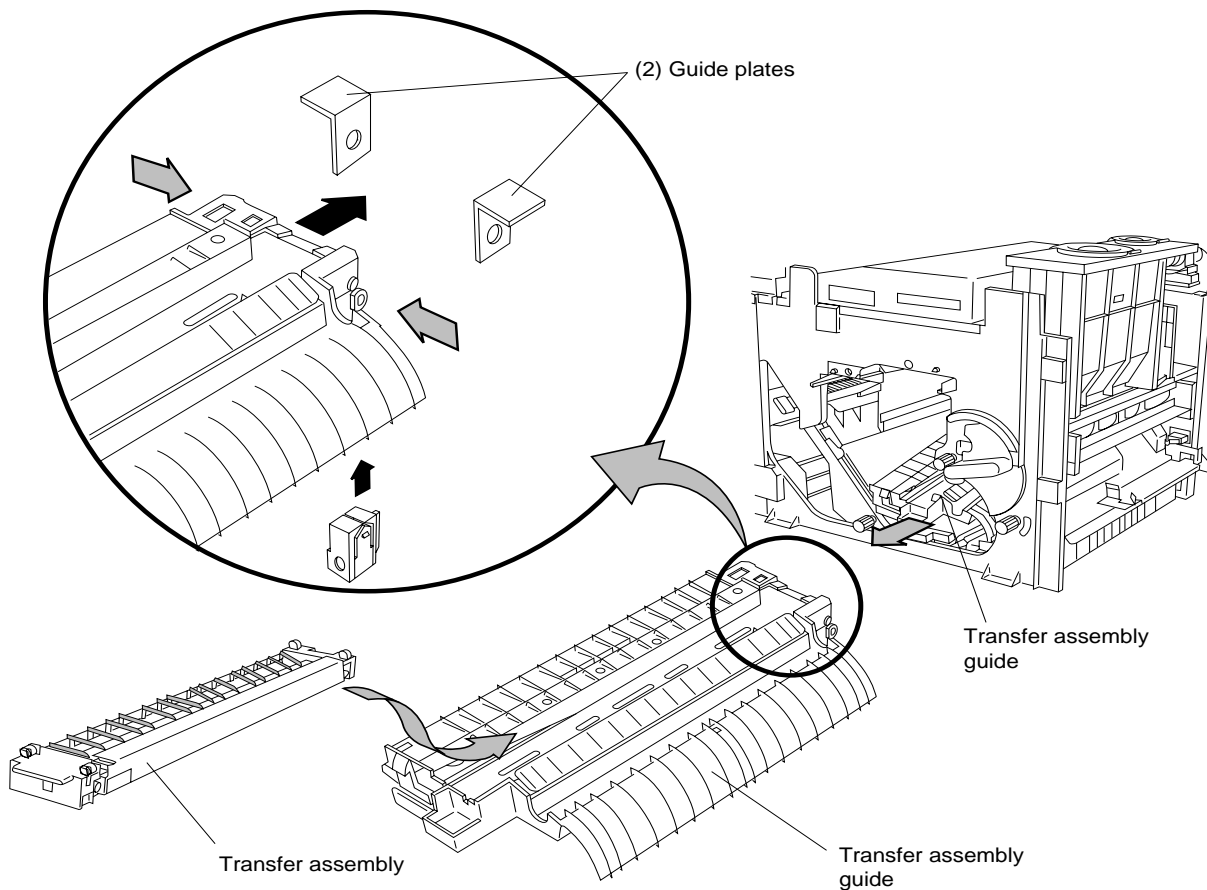

Figure 6-13. Transfer Assembly Guide

SERVICE MANUAL

Transfer Assembly Guide Replacement Procedure

Part Number

CA02626-F501

Tools Required

None

Replacement Procedure (removal)

Step	Instruction	Comment
1.	Open front door	
2.	<p style="text-align: center;">CAUTION May be HOT!</p> <p>Pull fuser out and set aside in safe area</p>	
3.	<p>Look inside and below the transfer guide assembly.</p> <p>Locate the 2 heavy-gauge power wires and the associated faston terminals</p> <p>Pull each down to disconnect Disconnect a connector and a fasten grounding</p>	<p>+HV (Black terminal) is to the far right</p> <p>ACH (Clear terminal) is to left of +HV</p>
4.	Remove the drum	
5.	<p style="text-align: center;">CAUTION</p> <p>Remember the orientation of the locking blocks as you remove them.</p> <p>Pull down both plastic locking blocks</p>	Notice that the block open side faces inward
6.	Squeeze plastic pivot pins and pull down and out	

Replacement Procedure (mounting)

1.	<p style="text-align: center;">CAUTION</p> <p>The pins must locked in place.</p> <p>While squeezing the pivot pins, insert guide and raise into place</p>	
2.	Insert plastic blocks (open side facing inward)	
3.	Reconnect the +HV and ACH faston terminals	Black on right side
4.	Reinstall the drum	
5.	Raise and secure the transfer guide assembly	

6. Install the fuser
7. Close front door

SERVICE MANUAL

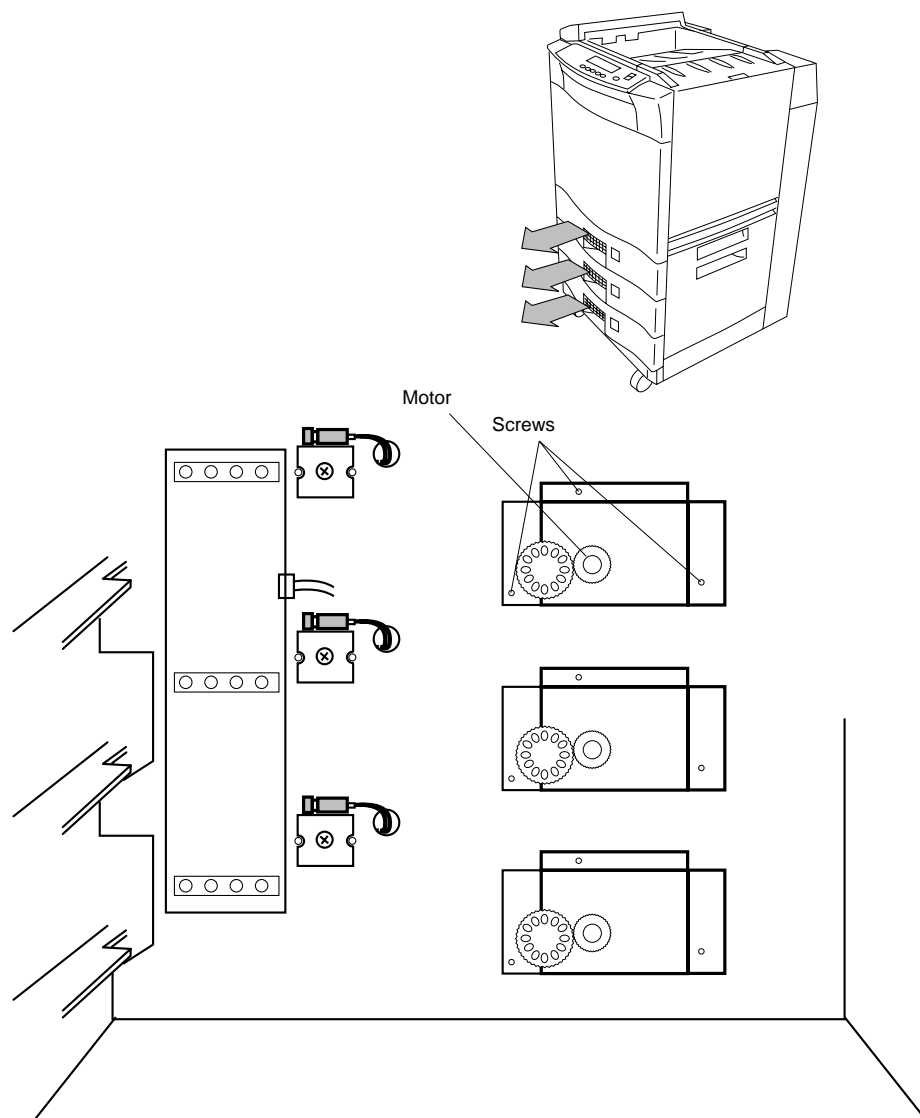
6-6.5. Paper Tray Lift Motor**Figure 6-14. Paper Tray Lift Motor**

SERVICE MANUAL

Paper Tray Lift Motor Replacement Procedure

Part Number

CA02626-E157

Tools Required

Magnetized 8-inch, number-2 Phillips-head screwdriver

Replacement Procedure (removal)

Step	Instruction	Comment
1.	Open front door	
2.	Remove all paper trays	Identify which tray is top, middle, and bottom
3.	Locate failed lift motor and remove 3 mounting screws	
4.	Disconnect a connector	

Replacement Procedure (mounting)

1. Install motor with 3 screws
2. Install paper trays
3. Close door

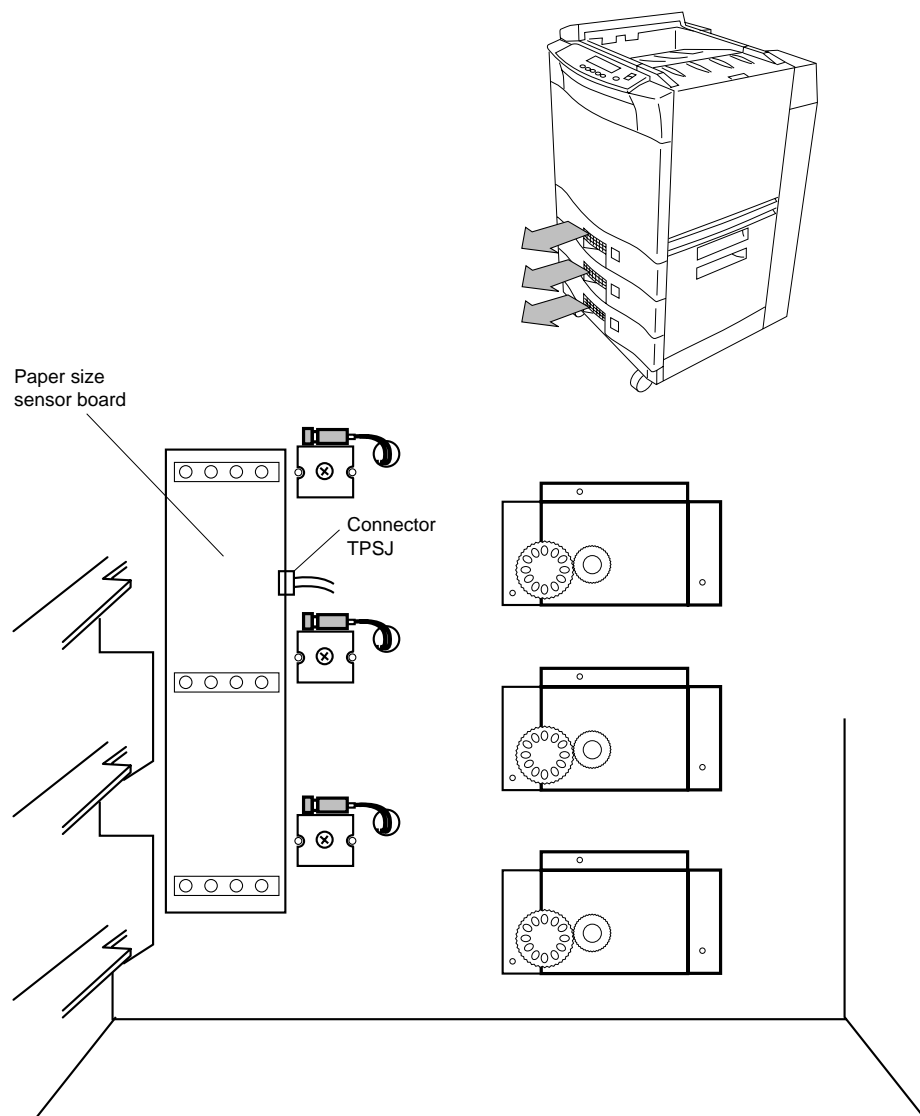
6-6.6. Paper Size Sensor Board**Figure 6-15. Paper Size Sensor Board**

SERVICE MANUAL

Paper Size Sensor Board Replacement Procedure

Part Number

CA02626-0179

Tools Required

Magnetized 8-inch, number-2 Phillips-head screwdriver

Replacement Procedure (removal)

Step	Instruction	Comment
1.	Open front door	
2.	Remove all paper trays	Identify which tray is top, middle, and bottom
3.	Locate failed sensor board and remove cable connector TPSJ.	
4.	Remove paper size sensor board	

Replacement Procedure (mounting)

1.	Install new sensor board	
1.	Reattach cable connector TPSJ.	
2.	Install paper trays	Install in original positions
3.	Close door	

6-7. Top of Printer Accessed FRUs

6-7.1. Main Controller Board

Figure 6-16. Main Controller Board

Main Controller Board Replacement Procedure

Part Number

XXXXXXX-XX

Tools Required

Magnetized 8-inch, number-2 Phillips-head screwdriver

Nut driver

Anti-static mat

ESD wrist strap

Replacement Procedure (removal)

NOTE

The detailed procedure depends on the structure of the main controller installed.

NOTE

Always wear an ESD wrist strap properly grounded to the equipment. Always place logic device assemblies on the anti-static mat.

Step	Instruction	Comment
1.	Open upper-right cover	
2.	Remove rear cover	
3.	Rotate ejection unit into upward position	
4.	Remove operator panel: Page 6-29	
5.	<p>CAUTION</p> <p>Do not loosen or remove other assembly screws. These are spring tensioned</p> <p>Loosen top cover securing screw only</p>	Top cover is divided. The small section lifts off and the larger section slides free of the holding screws
6.	Carefully slide the cover open and lift slowly (fan wire attached)	

SERVICE MANUAL

7. Disconnect fan wire
8. Disconnect board connectors CN1, CN2, CN3, CN14, CN15, CN16, CN17, and INFO
9. Loosen cable harness strap
10. Disconnect INFO connector at other end Pay attention to cable folds for reattachment
11. **CAUTION** HDD/floppy assembly is heavy and may stress controller board
 Remove HDD and floppy drive before lifting main controller board
 Disconnect HDD connectors:
 - a. **CAUTION**
 Raise connector body to release cable

 Disconnect flat ribbon cable
 - b. Disconnect power connector
 - c. From front, **loosen** 2 HDD left side screws From I/O connector
 - d. Remove 2 right side screws
 - e. Lift HDD and set aside Floppy is attached from the bottom of the controller
12. Extract the IC card assembly Pull towards opening
13. Remove CN15 and CN16 bracket mounting screws
14. Open 4 board securing hooks and lift board (with the connector brackets attached) **CAUTION**
Place the controller board on the anti-static mat
15. Remove 2 floppy mounting screws and set drive aside Accessed from the bottom of board
16. Remove 8 I/O connector bracket screws being careful of the washers Phillip-head screwdriver and nut driver
17. Place new controller board on mat
18. Place old board in shipping container

Replacement Procedure (mounting)

1. Attach I/O connector brackets
2. Attach floppy
3. Attach board into hooks
4. Insert IC card assembly

5. Attach HDD
6. Connect HDD and floppy connectors
7. Install INFO cable and connectors
8. Attach other board connectors CN1, CN2, CN3, CN14, CN15, CN16, CN17
9. Connect cover fan connector
10. Position **all** cover keyhole openings over screws and slide cover into place
11. Tighten **only** the top cover screw
12. Reinstall operator panel assembly:
Page 6-29
13. Close all covers

SERVICE MANUAL

6-7.2. Optical Unit

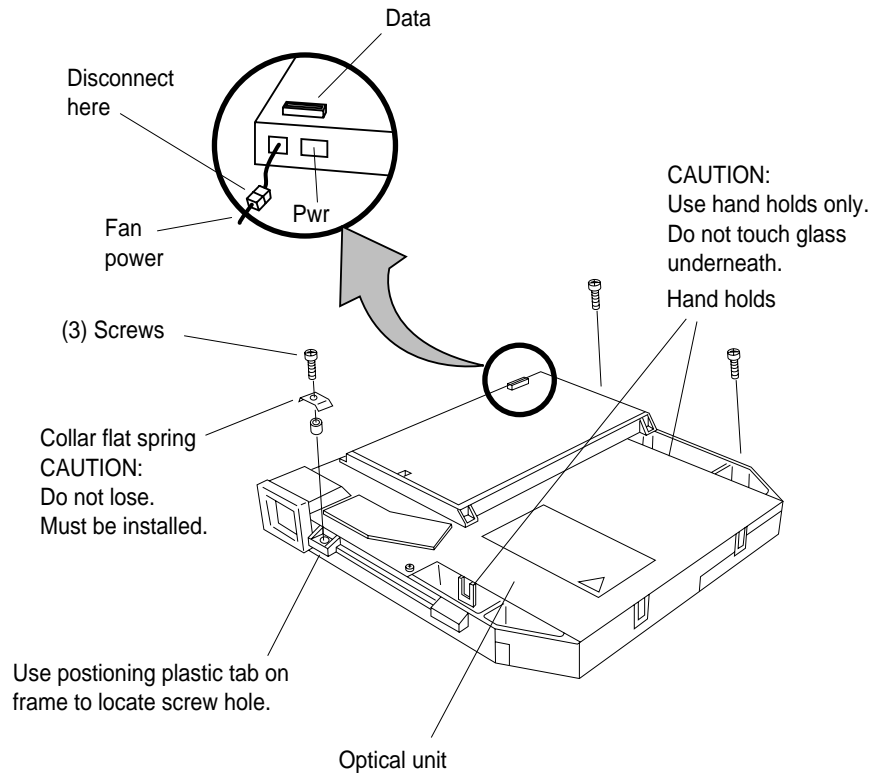

Figure 6-17. Optical Unit

Optical Unit Replacement Procedure

Part Number

CA02625-D105

Tools Required

Magnetized 8-inch, number-2 Phillips-head screwdriver

Nut driver

Anti-static mat

ESD wrist strap

Replacement Procedure (removal)

Step	Instruction	Comment
1.	Open upper-right cover	
2.	Remove rear cover	
3.	Rotate ejection unit upward	
4.	Remove operator panel assembly Page 6-29	Set assembly aside on safe flat surface
5.	Remove main controller assembly Page 6-42	CAUTION Place the controller board on the anti-static mat
6.	At optical unit, remove 3 screws	CAUTION Notice that one screw has a flat spring collar. DO NOT LOSE.
7.	Grasp the optical unit using the hand holds and carefully pull upward only as far as the cables allow	Do not grasp the edges - your fingers may cover the laser beam glass depositing grime or body oil
8.	Disconnect 3 connectors	Fan cable has an inline connection
9.	Remove failed optical unit and set aside	

Replacement Procedure (mounting)

1. Carefully install the new optical unit taking care not to touch the beam glass only as far as you can reattach the connectors

SERVICE MANUAL

2. Install (do not tighten) the 3 screws - the spring collar must be installed at the unit front Use the plastic positioning tab (on frame) to align the screw hole
3. Tighten all screws
4. Reinstall main controller board assembly Wrist strap required
Page 6-42
5. Reinstall operator panel assembly
Page 6-29
6. Close all covers

SERVICE MANUAL

6-8. Rear of Printer Accessed FRUs

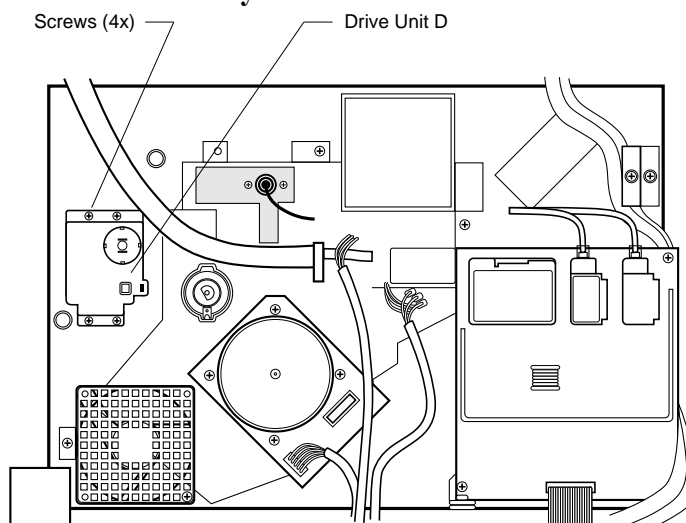
6-8.1. Drive Unit D Motor Assembly**Figure 6-18. Drive Unit D Motor Assembly**

SERVICE MANUAL

Drive Unit D Motor Assembly Replacement Procedure

Part Number

CA02626-F600

Tools Required

Magnetized 8-inch, number-2 Phillips-head screwdriver

Replacement Procedure (removal)

Step	Instruction	Comment
1.	Open upper-right cover	
2.	Remove rear cover	
3.	Disconnect connector MGSJH	
4.	Release cable from cable clamp	
5.	Disconnect 2 faston terminals from micro-switch	
6.	Remove 2 motor assembly bracket screws NOTE - remove cam and square shaft Caution - Don't lose red painted screws	Cam and shaft will be remounted

Replacement Procedure (removal)

1. Install motor assembly bracket using cam and shaft
2. Reconnect micro-switch connections
3. Reconnect MGSJH connector and secure cable in clamp
4. Close all covers

6-8.2. Mechanism Controller Board

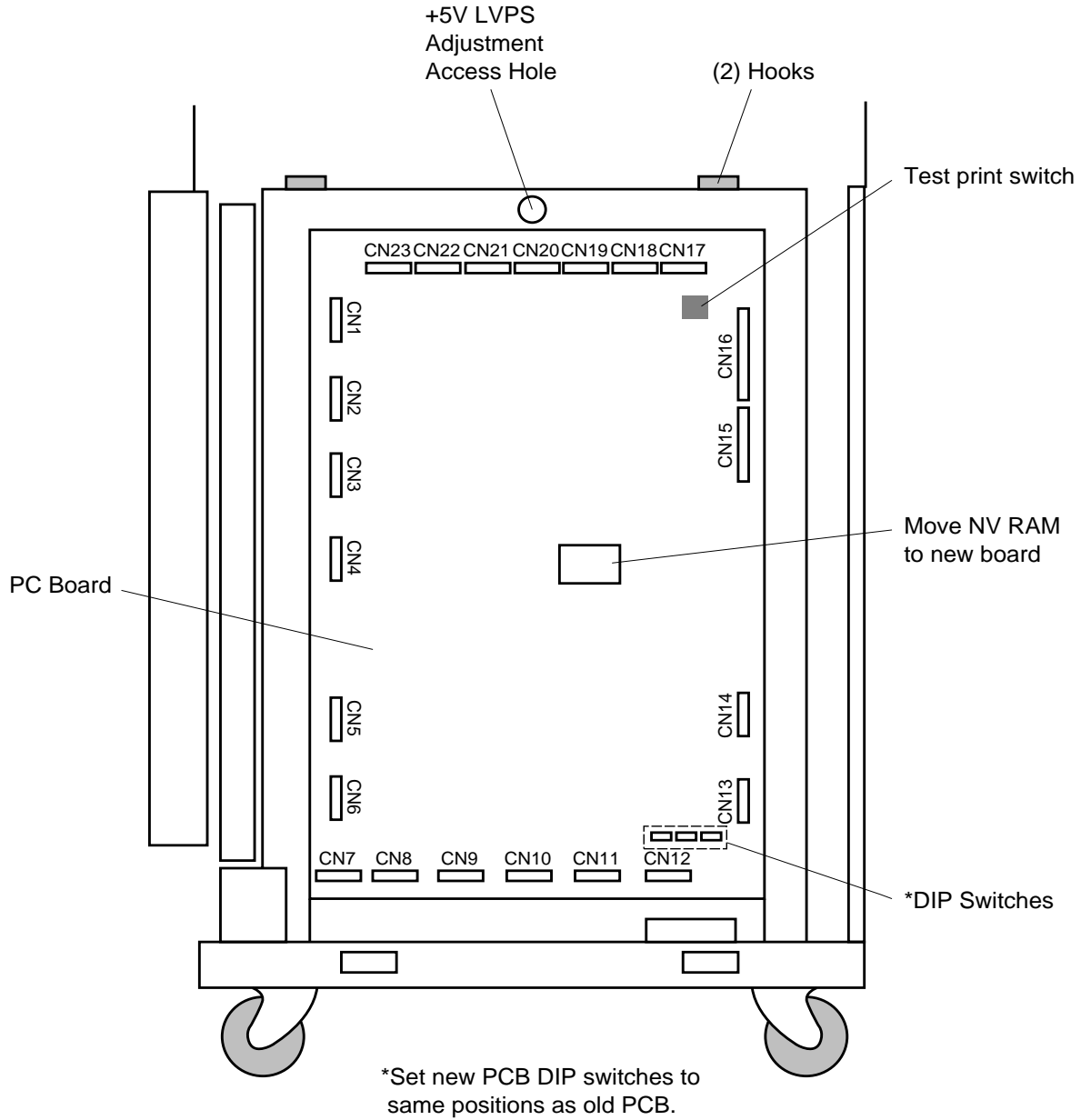

Figure 6-9. Mechanism Controller Board

Mechanism Controller Board Replacement Procedure

Part Number

CA02626-J002

Tools Required

Magnetized 8-inch, number-2 Phillips-head screwdriver

IC extractor/insertion tool

ESD wrist strap

Anti-static mat

Replacement Procedure (removal)

NOTE

Always wear an ESD wrist strap properly grounded to the equipment. Always place logic device assemblies on the anti-static mat.

Step	Instruction	Comment
1.	Open upper-right cover	
2.	Remove rear cover	
3.	On the mechanism controller board, disconnect I/O connectors CN1 through CN16, CN18, CN20 through CN23	CN17 and CN19 vacant Squeeze white tabs on CN10 and CN11 to pull off connectors
4.	<p style="text-align: center;">CAUTION</p> <p>Wrist strap required.</p> <p>Using an IC extractor, lift off the NV RAM IC</p>	Non-Volatile RAM located in center-right of board
5.	<p style="text-align: center;">CAUTION</p> <p>Place new board on anti-static mat.</p> <p>Insert IC into new controller board</p>	Pin 1 to pin 1
6.	Record on a piece of paper, the DIP switch settings for all 3 DIP packages	Located lower right corner of controller board
7.	Set these DIP switch settings on the new controller board	Make room on the mat for the old controller board - or - prepare the empty shipping container to hold the old board

8. With thumb pressure, release the 2 board mounting hooks Located on top of installed controller board
9. As you raise the board from the bottom supports, tilt the top of the board towards you
10. Place the failed board on the mat or into the shipping container

Replacement Procedure (mounting)

1. Install the new controller board into bottom supports and secure top clips
2. Attach all connectors
3. Close all covers **except** rear cover
4. Perform *Laser Start Position Alignment*
Page 6-18
5. Perform *Paper Feed System Alignment*
Page 6-20
6. Close rear cover

NOTE

This page intentionally left blank.

6-8.3. Registration Roller Standby Clutch

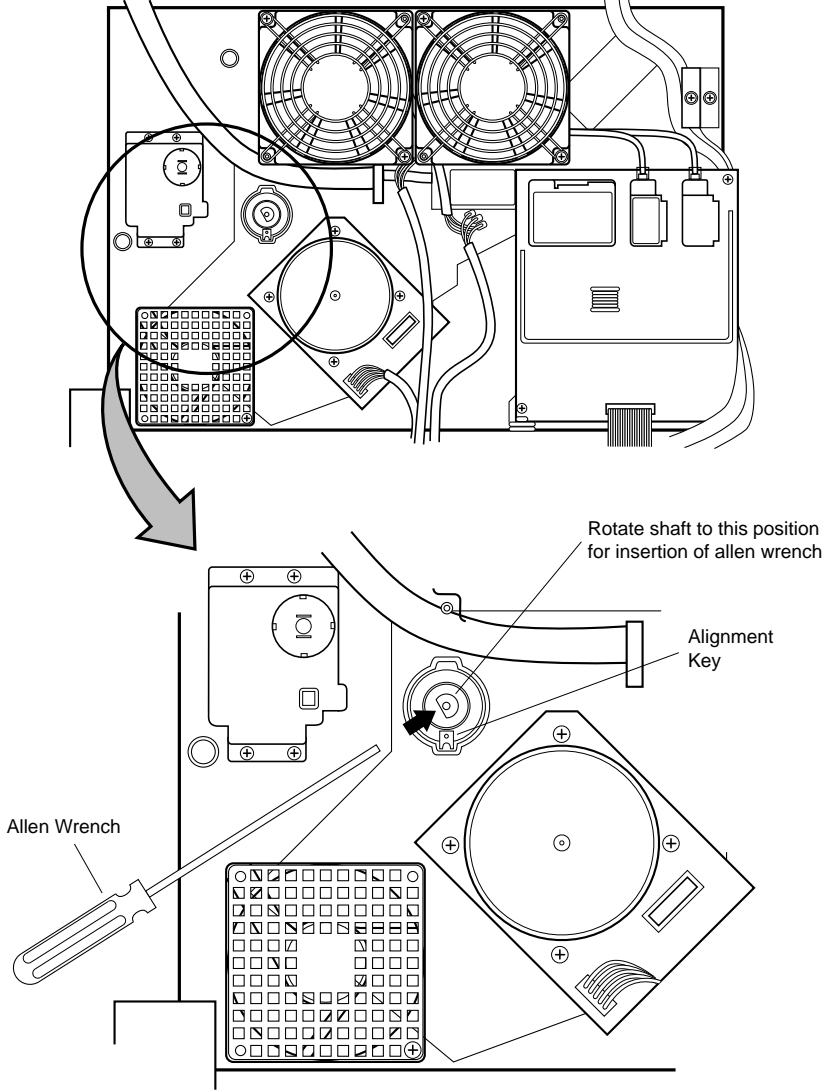

Figure 6-10. Registration Roller Standby Clutch

Registration Roller Standby Clutch Replacement Procedure

Part Number

B86L-2410-0880A

Tools Required

Magnetized 8-inch, number-2 Phillips-head screwdriver

Magnetized 2-mm 2-mm Allen (hexagon) wrench

Replacement Procedure (removal)

Step	Instruction	Comment
1.	Open upper-right cover	
2.	Remove rear cover	
3.	Disconnect inline connector RCLP	
4.	Remove clutch set screw using 2-mm Allen wrench	Notice - 1. The set screw is set into shaft flat side 2. Rotate the shaft to allow the wrench to fit into groove molded into base plate. 3. Clutch positioning tab fits into lower groove molded into base plate.
5.	Pull clutch out	

Replacement Procedure (mounting)

1.	Install new clutch	Notice - 1. Clutch positioning tab fits into lower groove molded into base plate. 2. Rotate the shaft to allow the wrench to fit into groove molded into base plate. 3. The set screw is set into shaft flat side
2.	Reconnect RCLP	
3.	Close all covers	

6-8.4. High Voltage Power Supply

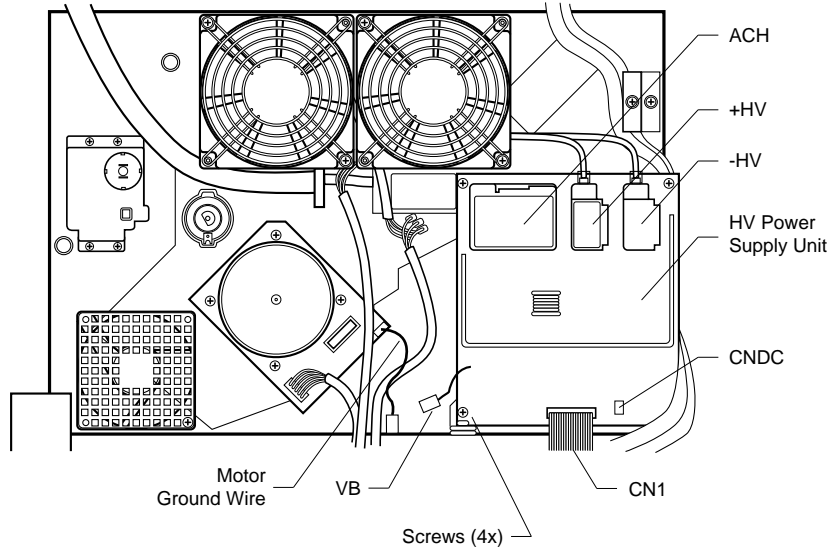

Figure 6-11. High Voltage Power Supply

High Voltage Power Supply Replacement Procedure

Part Number

CA02951-3621

Tools Required

Magnetized 8-inch, number-2 Phillips-head screwdriver

Replacement Procedure (removal)

Step	Instruction	Comment
1.	Open upper-right cover	
2.	Remove rear cover	
3.	Disconnect HVPS connections +HV and -HV	ACH connector disconnected in step 6
4.	Disconnect connectors VB, CN1, and CNDC	
5.	Remove 4 HVPS mounting screws	
6.	Disconnect HVPS connection ACH	
7.	Remove failed HVPS board	

Replacement Procedure (mounting)

1. Install ACH connection
2. Install new HVPS with 4 mounting screws
3. Reconnect connectors VB, CN1, and CNDC
4. Reconnect HVPS connectors +HV and -HV
5. Close all covers

6-8.5. Low Voltage Power Supply

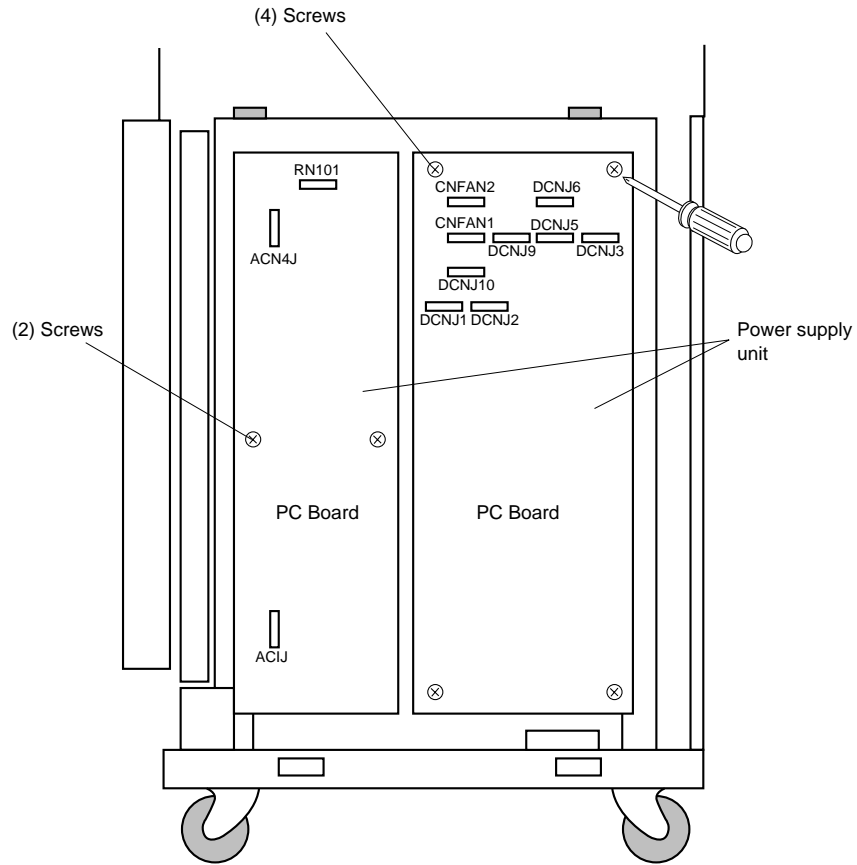

Figure 6-12. Low Voltage Power Supply

Low Voltage Power Supply Replacement Procedure

Part Number

CA02951-3631

Tools Required

Magnetized 8-inch, number-2 Phillips-head screwdriver

IC extractor/insertion tool

ESD wrist strap

Anti-static mat

Replacement Procedure (removal)

NOTE

Always wear an ESD wrist strap properly grounded to the equipment. Always place logic device assemblies on the anti-static mat.

Step	Instruction	Comment
1.	Open upper-right cover	
2.	Remove rear cover	
3.	Remove all mechanism controller board I/O connectors (Page 6-51)	
4.	Remove mechanism controller board mounting bracket:	PCB remains on bracket
a.	Remove main motor ground wire faston connector	
b.	Remove all cable clamp restrictions on bracket	
c.	Remove 2 (left and right side) bracket mounting screws	
d.	Remove bracket assembly and set aside	
5.	On left LVPS PCB, disconnect connectors RN101, ACN4J, and AC1J	
6.	On right LVPS PCB, disconnect connectors CNFAN1, CNFAN2, DCNJ1, DCNJ2, DCNJ3, DCNJ5, DCNJ6, DCNJ9 and DCNJ10	
7.	Remove 2 interboard cables and set aside	
8.	On left PCB, remove 2 mounting screws, pull board off tabs, and set failed PCB aside	

9. On right PCB, remove 4 mounting screws, pull board off tabs, and set failed PCB aside

Replacement Procedure (mounting)

1. Install right PCB with 4 screws
2. Install left PCB with 2 screws
3. Reinstall 2 interboard cables
4. On right LVPS PCB, reconnect connectors CNFAN1, CNFAN2, DCNJ1, DCNJ2, DCNJ3, DCNJ5, DCNJ6, DCNJ9 and DCNJ10
5. On left LVPS PCB, reconnect connectors RN101, ACN4J, and AC1J
6. Install mechanism controller board mounting bracket assembly with 2 screws
7. Install cables into clamps and secure
8. Reconnect all mechanism controller board I/O connectors
Page 6-51
9. Adjust +5V output voltage
Page 6-16
10. Close all covers

6-8.6. Low Voltage Power Supply Fan

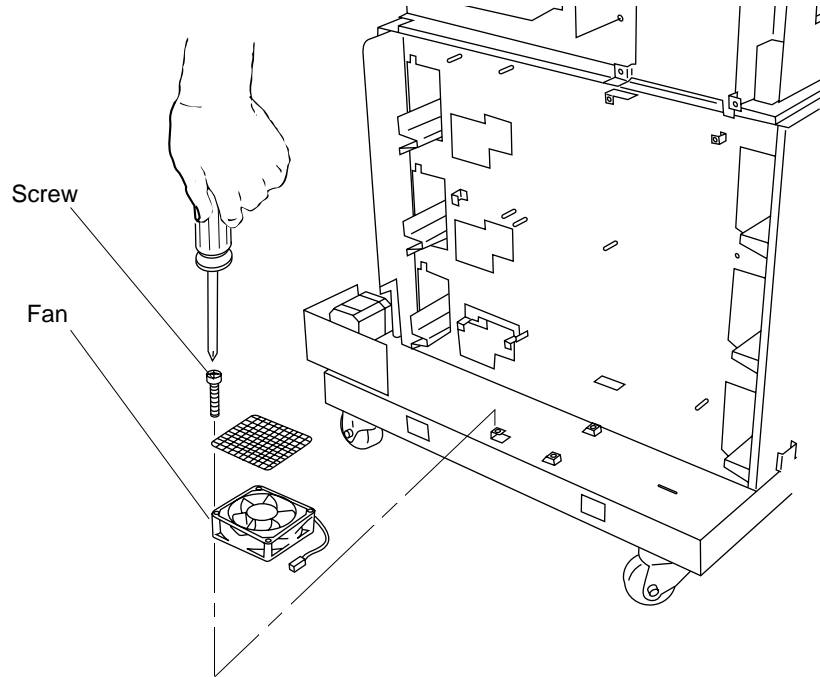

Figure 6-13. Low Voltage Power Supply Fan

Low Voltage Power Supply Fan Replacement Procedure

Part Number

CA02626-E159

Tools Required

Magnetized 8-inch, number-2 Phillips-head screwdriver

Replacement Procedure (removal)

Step	Instruction	Comment
1.	Open upper-right cover	
2.	Remove rear cover	
3.	Remove both LVPS PCBs Page 6-59	
4.	Remove fan bracket mounting screws and pull fan bracket forward	
5.	Disconnect FAN5P connector	
6.	Remove 3 fan mounting screws and remove failed fan	Fan 5

Replacement Procedure (mounting)

1. Install new fan onto bracket
1. Reconnect FAN5P connector
2. Install bracket onto frame
3. Install LVPS PCBs
Page 6-59
4. Close all covers

6-8.7. Power Sequencing Relay

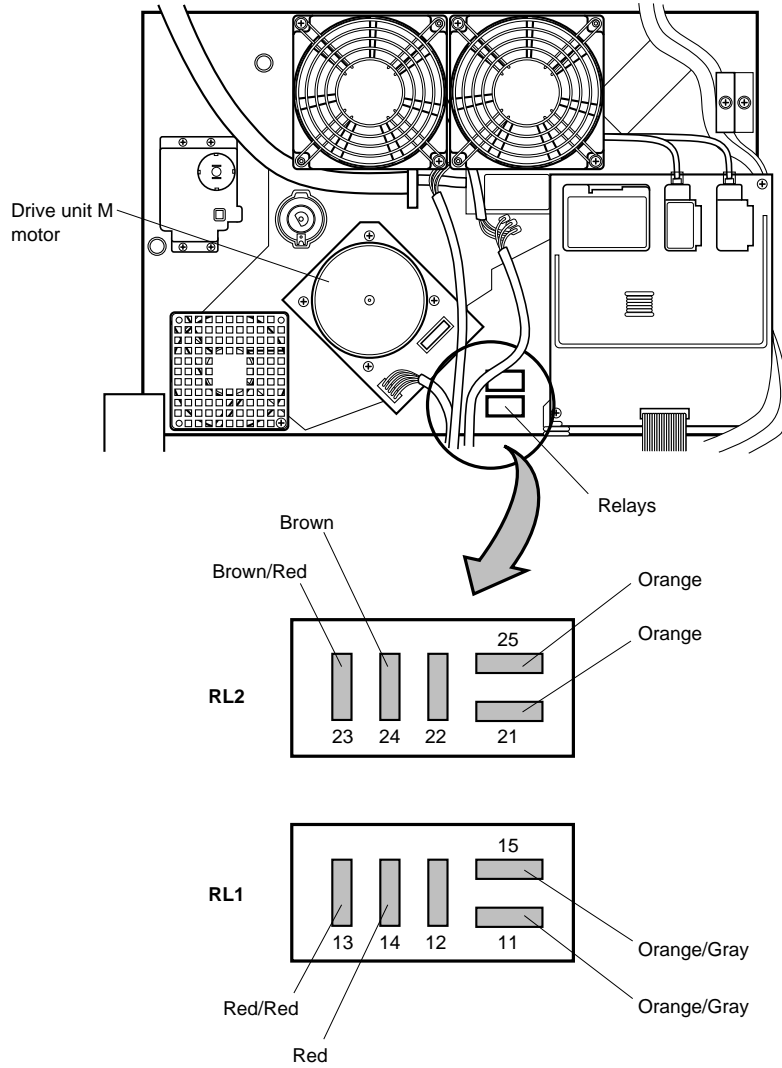

Figure 6-14. Power Sequencing Relay

Power Sequencing Relay Replacement Procedure

Part Number

CA98001-6948

Tools Required

Magnetized 8-inch, number-2 Phillips-head screwdriver

Replacement Procedure (removal)

Step	Instruction	Comment
1.	Open upper-right cover	
2.	Remove rear cover	
3.	Remove 2 relay mounting screws	
4.	Slide the relay to the left to free the relay from the frame	
5.	While holding relay, disconnect the faston terminals	

Replacement Procedure (mounting)

1. While holding new relay, reconnect faston terminals:
 - a. Top row:
Brown/Red Brown Orange Orange See label map below relay
 - b. Bottom row:
Red/Red Red Orange/Gray Orange/Gray
2. Mount and secure relay with 2 screws
3. Close all covers

6-8.8. Drive Unit M

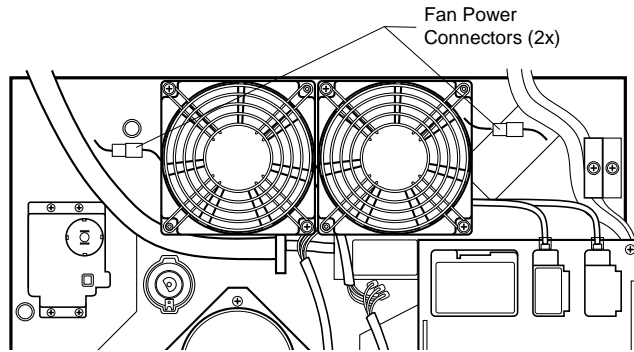

Figure 6-15. Drive Unit M Fan Connectors

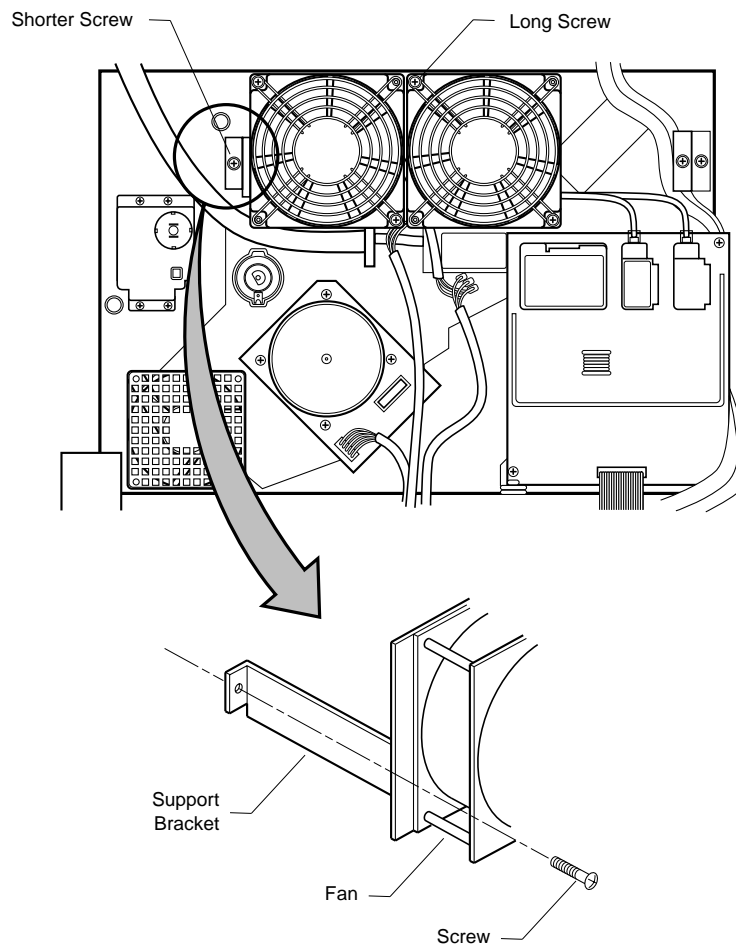

Figure 6-16. Fan Bracket Mounting Screws

Drive Unit M Replacement Procedure

Part Number

CA02626-E732

Tools Required

Magnetized 8-inch, number-2 Phillips-head screwdriver

Magnetized 12-inch, number-2 Phillips-head screwdriver

Magnetized 2-mm Allen wrench

Replacement Procedure (removal)

Step	Instruction	Comment
1.	Open upper-right cover	
2.	Open front door	
3.	Remove back cover	
4.	Remove top cover	
5.	CAUTION May be HOT!	
	Pull fuser unit out and set aside in safe area	
6.	Lower transfer guide assembly	
7.	Remove drum unit	
8.	Remove toner collector bottle	
9.	At rear of printer, remove 3 screws securing top plastic shield plate	
10.	Locate and unsnap 4 inline fan power connectors FAN2P, FAN3P, FAN4P, and FAN7P	<p>Figure 6-15 shows FAN2P and FAN4P</p> <p>FAN3P connects small fan and FAN7P connects lower fan</p> <p>Fan3 may not be installed in your printer</p>

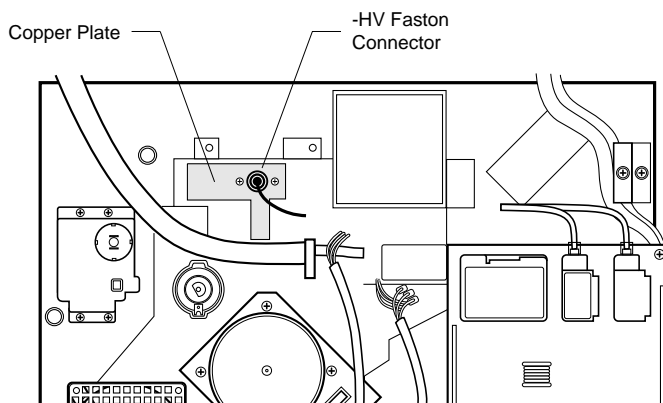

Figure 6-17. -HV Connector

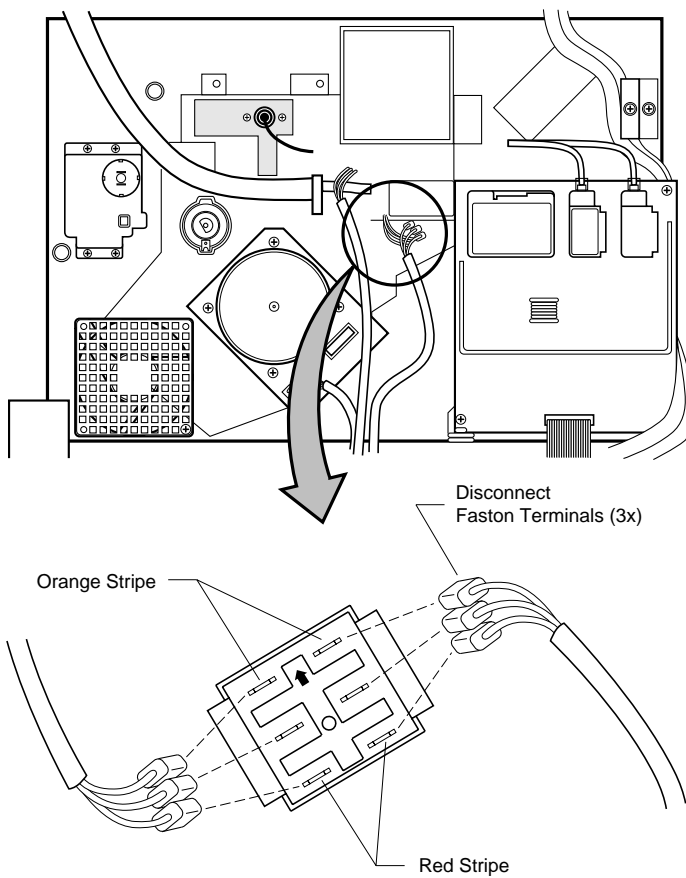

Figure 6-18. Interlock Terminals

- | | | |
|-----|---|---|
| 11. | Remove 2 screws securing fan assembly and set aside | Figure 6-16 |
| | | Release fan cables from cable holders |
| 12. | Disconnect -HV faston terminal | Figure 6-17 |
| 13. | Disconnect 6 fuser interlock faston terminals | Figure 6-18 |
| | | 2 cables harnesses (LVPS and fuser) |
| 14. | Disconnect RCLP faston terminal | Figure 6-19 |
| 15. | On mechanism controller board, disconnect CNJ21 connector | Figure 6-19 |
| 16. | Remove registration roller clutch set screw using 2-mm Allen wrench | Figure 6-20 |
| | | <p>Notice -</p> <ol style="list-style-type: none"> 1. The set screw is set into shaft flat side 2. Rotate the shaft to allow the wrench to fit into groove molded into base plate. 3. Clutch positioning tab fits into lower groove molded into base plate. |
| 17. | Pull clutch out and set aside | |
| 18. | <p style="text-align: center;">CAUTION</p> <p>When toner hose is pulled out, toner will spill out.</p> <p>At toner hopper housing, detach the clamped-on hose plug and remove 2 hose mounting screws</p> | <p>This is where the white hose enters the hopper</p> <p>Use 12-inch screwdriver to access screws</p> |
| 19. | At the toner slide control, remove 2 bracket screws to free the white hose assembly | |
| 20. | Attach the hose plug over the open hose end | <p>NOTE - If plug is missing, wrap material over the hose and secure</p> |

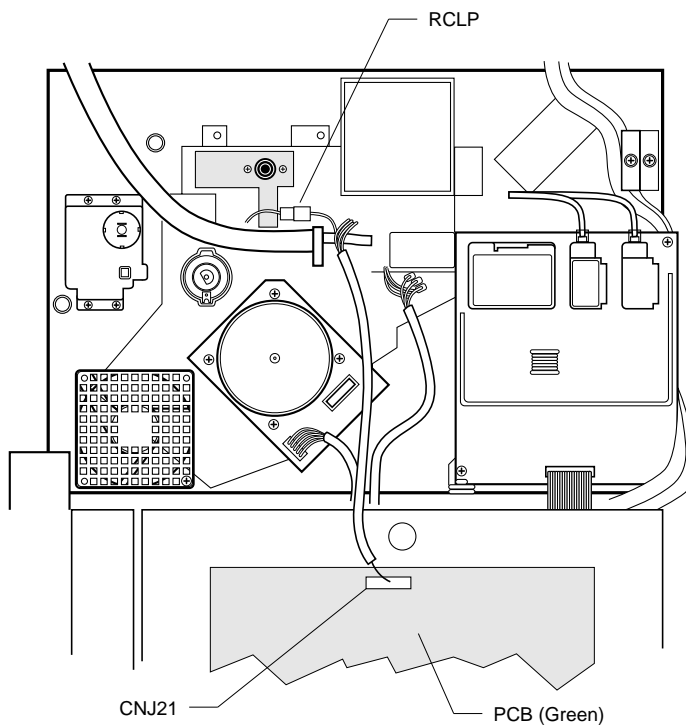

Figure 6-19. Clutch and Mechanism Controller Connectors

- | | | |
|-----|---|---|
| 21. | Release high voltage cables from Fan4 duct cable clamp | |
| 22. | Disconnect ACH, +HV, and -HV at HVPS | Figure 6-21 |
| 23. | Locate faston ground wire from motor board-to-frame and disconnect from frame | |
| 24. | On drive unit M assembly, remove 3 mounting screws | Figure 6-22 |
| | | Lower left, lower right, and upper right |
| | | Hooks hold assembly in place |
| 25. | Lift assembly to free holding hooks and remove | NOTICE -
1. While carrying unit, tilt unit backward to prevent toner spilling
2. Lay unit M down with inside of unit facing UP |

Replacement Procedure (removal)

- | | | |
|----|---|-------------------------|
| 1. | <p style="text-align: center;">CAUTION</p> Unit springed assembly must be carefully positioned over tensioner

Install new unit over frame hooks | |
| 2. | Attach unit with 3 short screws | Figure 6-22 |
| 3. | Reconnect motor board ground wire | |
| 4. | Reconnect cables ACH, +HV, and -HV into HVPS and then into FAN4 cable clamp | Figure 6-21 |
| 5. | <p style="text-align: center;">CAUTION</p> Before removing hose plug, hold hose end vertical and gently tap the end with your finger to knock down any toner caught in the plug.

Remove plug and insert hose nozzle into toner hopper | |
| 6. | Attach toner hopper bracket screws | Use 12-inch screwdriver |

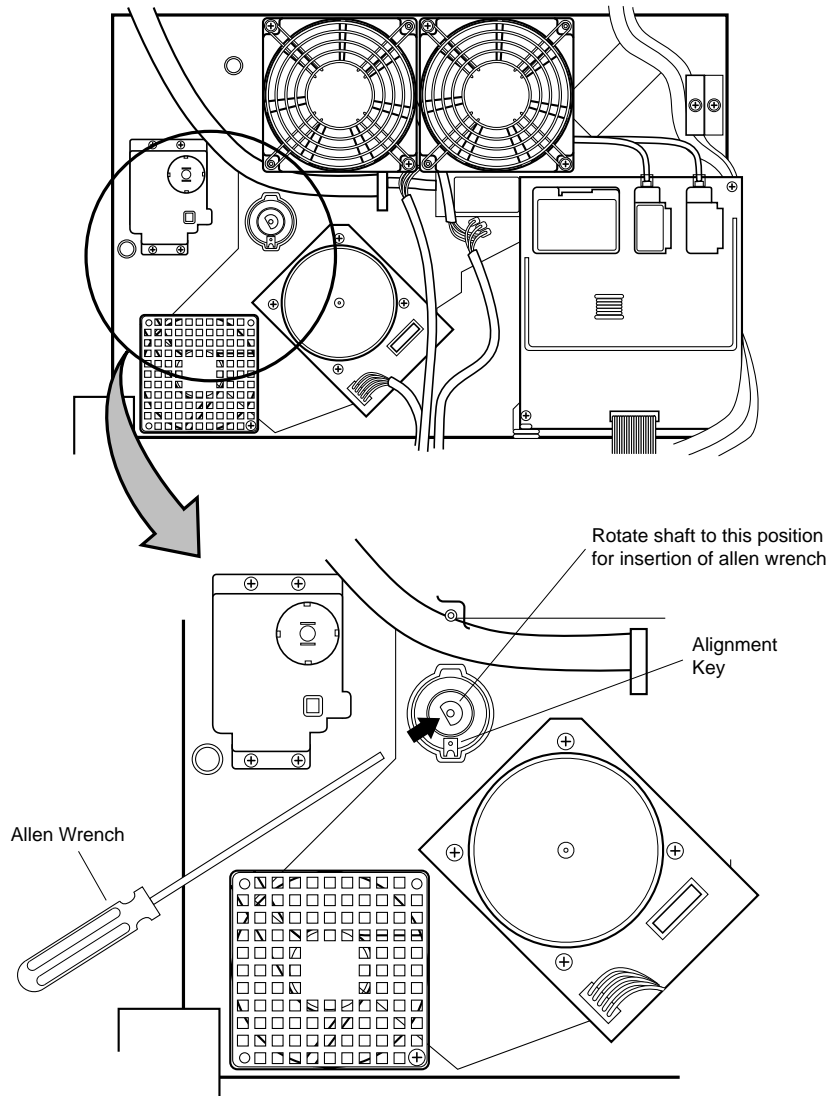

Figure 6-20. Clutch Mounting Screw

- | | | |
|-----|---|---|
| 7. | Attach slide control bracket screws | |
| 8. | Install clutch and secure with set screw | Figure 6-20

Clutch locating tab down |
| 9. | Attach cable connectors CNJ21 and RCLP | Figure 6-19 |
| 10. | Reconnect 3 LVPS faston terminals to right side of fuser interlock switch | Figure 6-18

Top - Orange stripe
Middle - White
Bottom - Red stripe |
| 11. | Reconnect 3 fuser faston terminals to left side of fuser interlock switch | Top - Orange stripe
Middle - White
Bottom - Red stripe |
| 12. | Reconnect -HV faston terminal | Figure 6-17 |
| 13. | Install fan and secure with 2 screws | Figure 6-16 |
| 14. | Attach 4 inline fan connectors (FAN2P, FAN3P, FAN4P, and FAN7P) | Figure 6-15 |
| 15. | Install top shield plate and secure with 2 screws | |
| 16. | Install toner collector bottle | Remove cap and attach cap to bottle side |
| 17. | Attach connectors TNSP and VB | Developer unit cables |
| 18. | Install drum unit | |
| 19. | Close transfer guide assembly | |
| 20. | Install fuser unit | |
| 21. | Close all covers | |
| 22. | From old unit, carefully remove the hose plug, clean it, and attach it to the toner hopper hose | Plug the old unit open toner hose end for proper disposition of the unit |

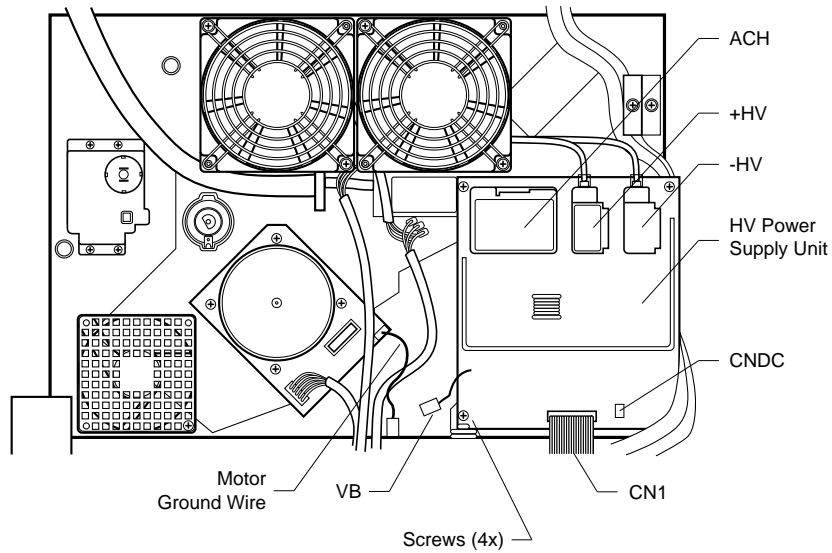

Figure 6-21. High Voltage Power Supply Connectors

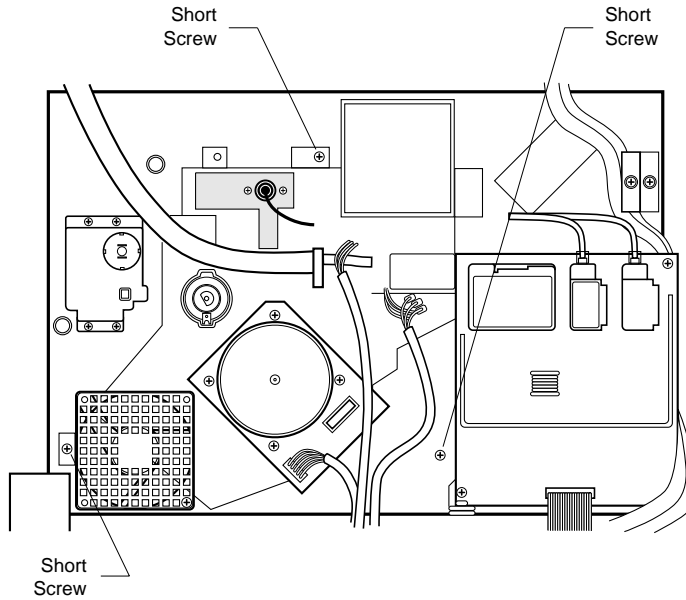

Figure 6-22. Drive Unit M Assembly Mounting Screws

6-8.9. Drive Unit M Lower Fan

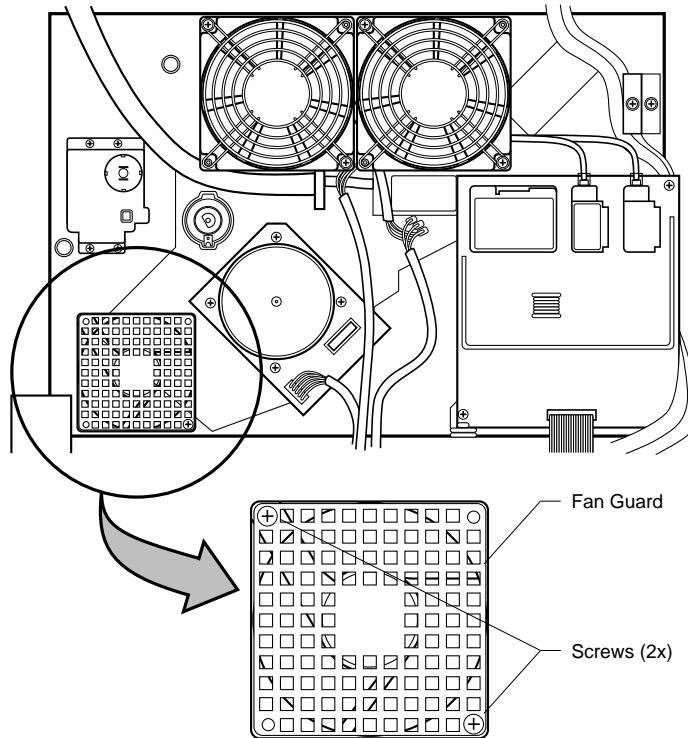

Figure 6-23. Drive Unit M Lower Fan

Drive Unit M Lower Fan Replacement Procedure

Part Number

CA02626-E718

Tools Required

Magnetized 8-inch, number-2 Phillips-head screwdriver

Replacement Procedure (removal)

Step	Instruction	Comment
1.	Open upper-right cover	
2.	Remove rear cover	
3.	Disconnect inline connector FAN7	
4.	Remove 2 long fan screws	
5.	Remove fan	Fan 7 Note the direction of finger guards.

Replacement Procedure (mounting)

1. Install fan with 2 screws
2. Reconnect FAN7 connector
3. Close all covers

6-8.10. Drive Unit M Waste Toner Screw Sensor

Figure 6-24. Drive Unit M Waste Toner Screw Sensor

Drive Unit M Waste Toner Screw Sensor Replacement Procedure

Part Number

B86L-2410-0882A

Tools Required

Magnetized 8-inch, number-2 Phillips-head screwdriver

Replacement Procedure (removal)

Step	Instruction	Comment
1.	Open upper-right cover	
2.	Remove rear cover	
3.	Disconnect connector SCRSJ	
4.	Remove sensor switch bracket screw	
5.	Grasp the bracket and:	Notice
a.	Tilt forward and lift the bracket holding-tab free of panel hole	1. That the toner feed screw shaft extends through the bracket bearing
b.	<p style="text-align: center;">CAUTION</p> <p style="text-align: center;">Do not lose bearing</p> <p>When free, move bracket slightly to right to free bearing from shaft</p>	2. That the shaft worm gear can be lifted free of the drive gear
6.	Remove switch from bracket by squeezing plastic tabs	

Replacement Procedure (mounting)

1.	Mount new sensor switch onto bracket	
2.	To install bracket:	
a.	On worm gear shaft, lift shaft to free gears to allow you to rotate the cam high side lobe inward	The high side lobe activates the switch
b.	Slip bearing onto shaft	Verify bearing flange is installed towards gear
c.	Position the bracket so that you can insert the small end of the bearing into the bracket hole while inserting bracket holding tab into panel hole	
3.	Secure bracket with screw	

4. Reconnect SCRSJ connector
5. Close all covers

6-8.11. Drive Unit M Fuser Interlock Switch (TINTSW)

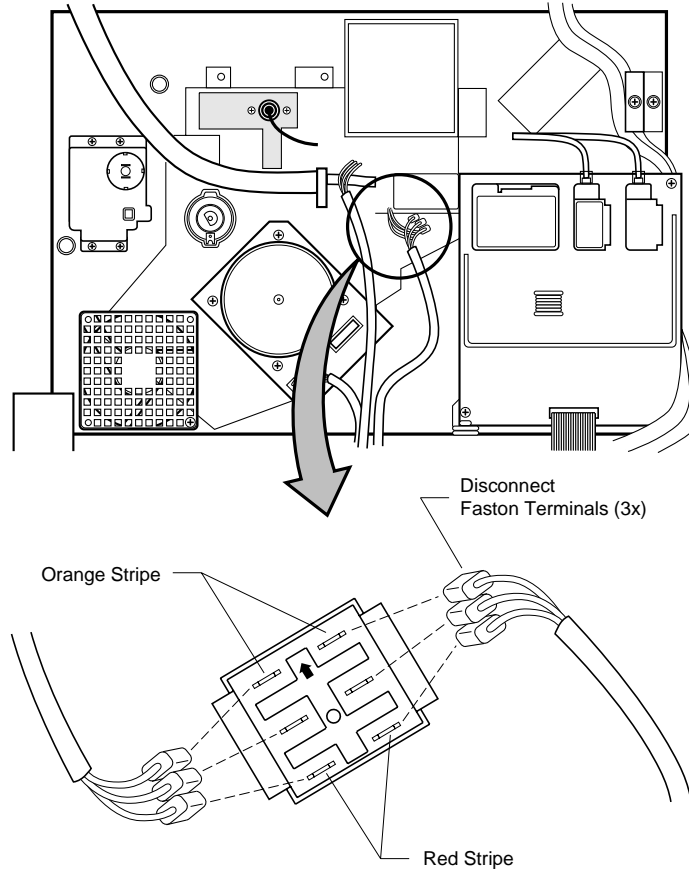

Figure 6-25. Fuser Unit Interlock Switch (TINTSW)

Drive Unit M Fuser Unit Interlock Switch (TINTSW) Replacement Procedure

Part Number

CA980001-6947

Tools Required

Magnetized 8-inch, number-2 Phillips-head screwdriver

Replacement Procedure (removal)

Step	Instruction	Comment
1.	Remove drive unit M Page 6-67	
2.	While standing drive unit M on the bottom edge, from the outside surface press on the switch securing tabs	Be careful of toner openings
3.	When free of the housing, remove the switch from inside the drive unit M	Observe the switch spring actuator orientation

Replacement Procedure (mounting)

1.	Install new switch by snapping into hole	The switch markings must show connector tab 1A at the top of the unit
2.	Reinstall drive unit M Page 6-67	Do not pinch any wires
3.	Close all covers	

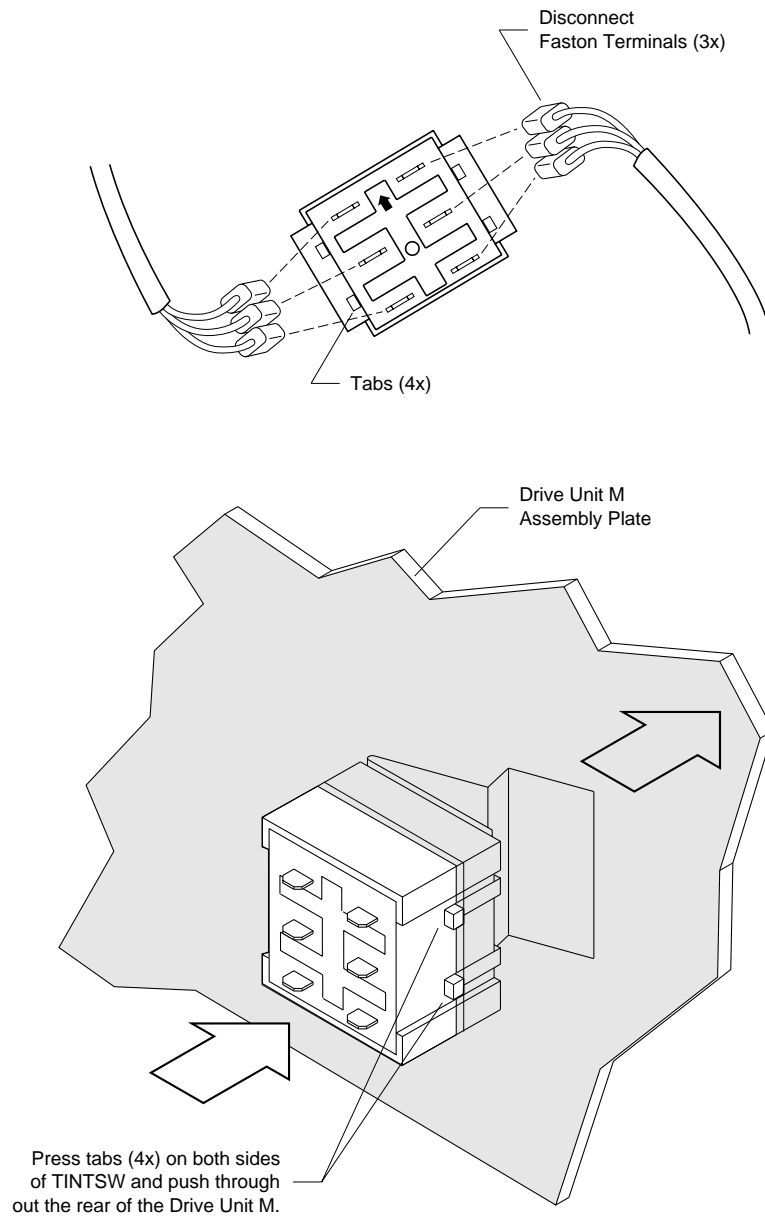

Figure 6-26. Fuser Unit Interlock Switch Removal

//

6-8.12. Drive Unit E to Ejection Unit Belt

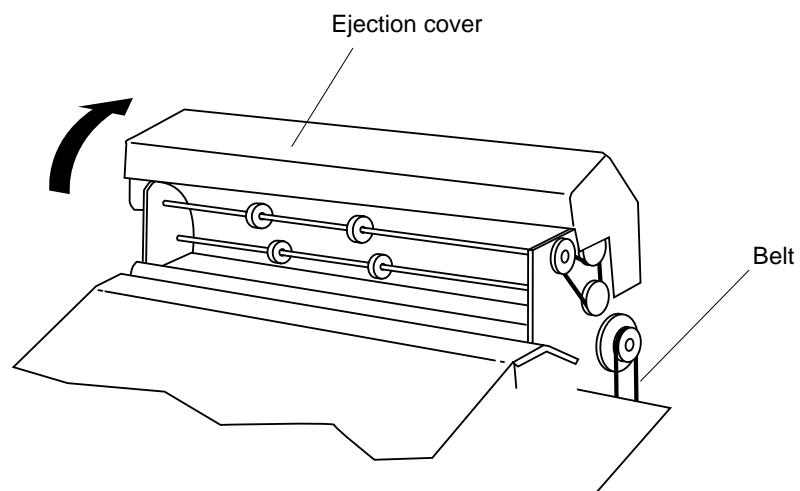

Figure 6-27. Drive Unit E to Ejection Unit Belt

Drive Unit E to Ejection Unit Belt Replacement Procedure

Part Number

CA98001-6942

Tools Required

Magnetized 8-inch, number-2 Phillips-head screwdriver

Replacement Procedure (removal)

Step	Instruction	Comment
1.	Open ejection unit cover	
2.	Open upper-right cover	
3.	Remove top cover	
4.	Remove rear cover	
5.	On ejection unit gear bracket, loosen 2 screws	Notice that the bracket has elongated screw slots to adjust belt tension. Also note the positioning pin in the 3rd slot.
6.	Lift belt off top and bottom gears	Note the belt path

Replacement Procedure (mounting)

1. Install new belt on gears
2. Verify that bracket positioning pin is inside the positioning slot
3.

CAUTION

Do not overtighten belt.

Position the bracket so that the belt is tight but has just a little depression when you press down on the belt
4. Close all covers

6-8.13. Drive Unit E Gear Assembly

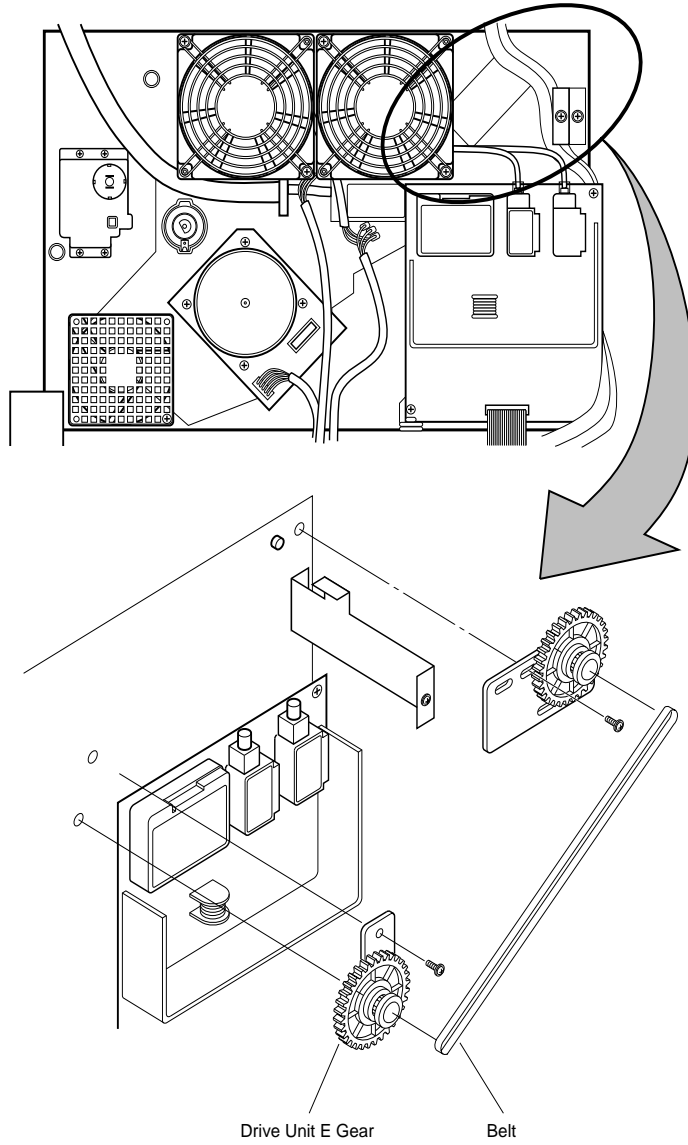

Figure 6-28. Drive Unit E Gear and Bracket Assembly

Drive Unit E Gear Assembly Replacement Procedure

Part Number

CA02626-E660

Tools Required

Magnetized 8-inch, number-2 Phillips-head screwdriver

Replacement Procedure (removal)

Step	Instruction	Comment
1.	Open upper-right cover	
2.	Remove top cover	
3.	Remove drive unit M bracket holding top fans	
4.	Disconnect HVPS -HV, +HV, and ACH faston connectors	
5.	Disconnect lower CN1 and CNDC connectors	
6.	Remove 5 HVPS bracket screws and set HVPS aside	3 screws holding hinge bracket and 2 screws holding right side
7.	On ejection unit gear bracket, loosen 2 screws Page 6-88	Notice that the bracket has elongated screw slots to adjust belt tension. Also note the positioning pin in the 3rd slot.
8.	Lift belt off top and bottom gears	Note the belt path. Check belt for wear.
9.	At drive unit E bracket, note the positioning-pin alignment then remove 2 bracket screws	

Replacement Procedure (removal)

1.
 - CAUTION**
 - Verify position-pin is in positioning slot.
 - Install new drive unit E gear bracket assembly and secure with 2 screws
2.
 - Install belt over gears
3.
 - CAUTION**
 - Do not overtighten belt.
 - Position the tensioning bracket so that the belt is tight but has just a little depression when you press down on the belt
4.
 - Tighten belt tensioning screws

5. Reinstall HVPS bracket with 5 screws
6. Reconnect HVPS connectors
7. Close all covers

6-8.14. PS5 - Duplex Unit Paper Path Sensor

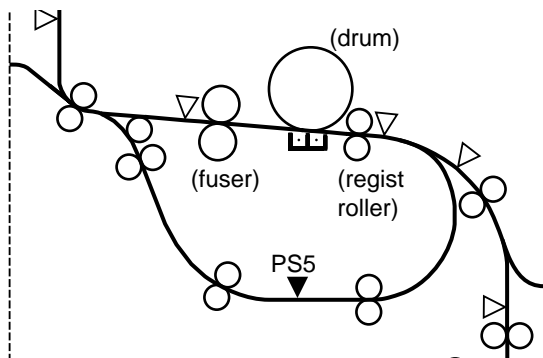

Figure 6-29. PS5 Positioning Overview

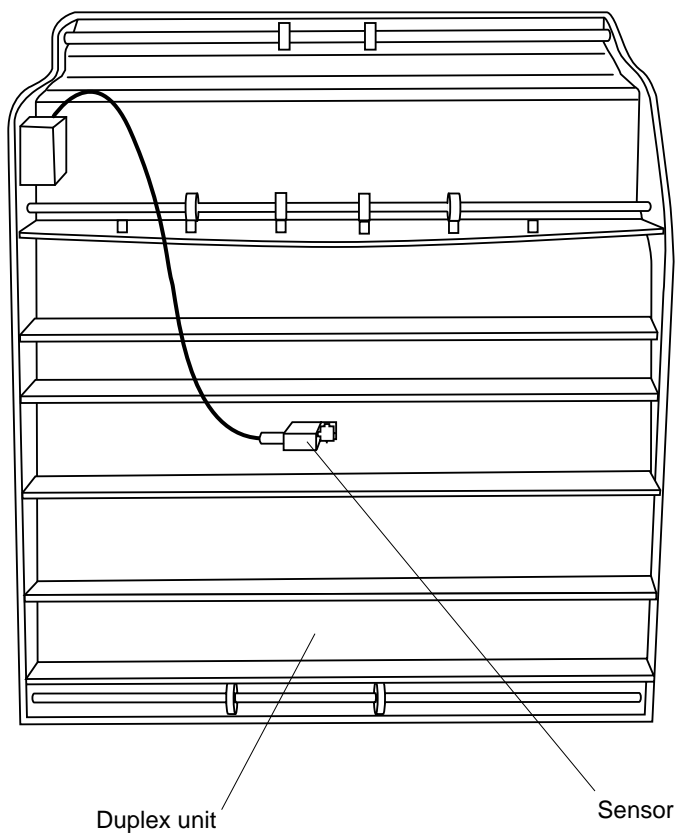

Figure 6-30. Duplex Unit Sensor PS5

PS5 - Duplex Unit Paper Path Sensor Replacement Procedure**Part Number**

CA55002-0337

Tools Required

Magnetized 8-inch, number-2 Phillips-head screwdriver

Replacement Procedure (removal)

Step	Instruction	Comment
1.	Remove duplex unit Page 6-22	
2.	Disconnect sensor connector PS5P	
3.	Squeeze sensor mounting tabs to release sensor	

Replacement Procedure (mounting)

1. Install new sensor
2. Reconnect PS5P connector
3. Reinstall duplex unit
Page 6-22

6-8.15. PS7 - Ejection Unit Paper Path Sensor

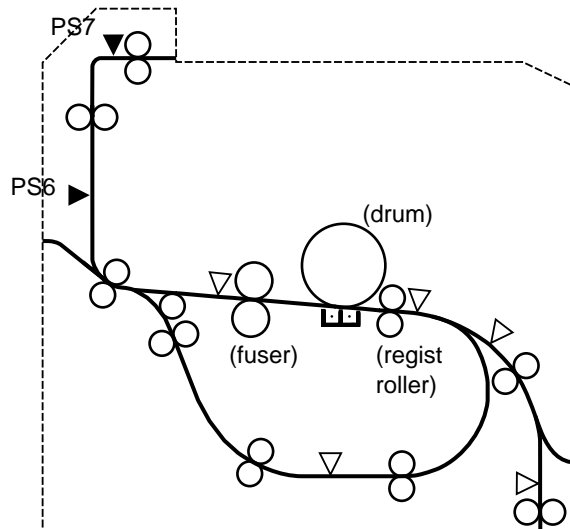

Figure 6-31. PS7 Positioning Overview

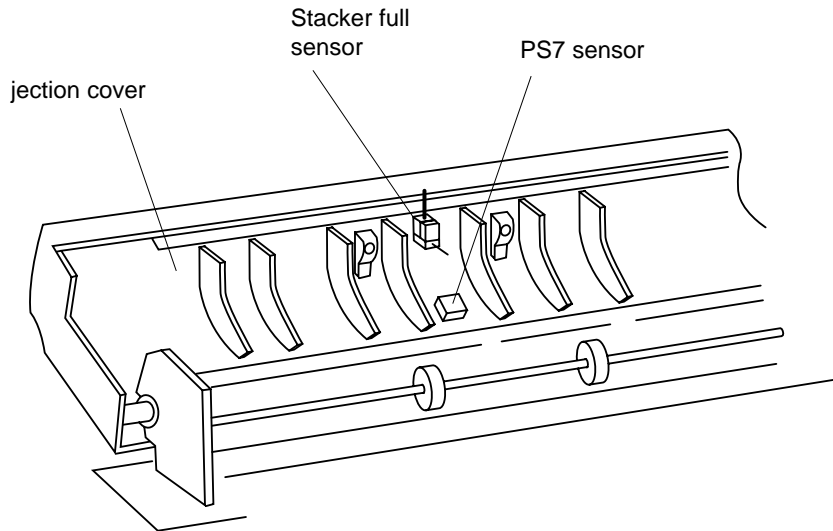

Figure 6-32. Ejection Unit Sensor PS7

PS7 - Ejection Unit Paper Path Sensor Replacement Procedure

Part Number

CA02951-5074

Tools Required

Magnetized 8-inch, number-2 Phillips-head screwdriver

Replacement Procedure (removal)

Step	Instruction	Comment
1.	Open upper-left ejection unit cover	
2.	Open upper-right cover	
3.	Remove top cover	
4.	<p style="text-align: center;">CAUTION</p> <p>Do not put any weight on ejection unit cover when it is not held with the strap hinge</p> <p>Remove bottom flat hinge strap mounting screw and fully open ejection cover</p>	
5.	Follow sensor cable down (and free from cable clamp) to connector board and then disconnect PS7J connector	
6.	Remove sensor bracket mounting screw	
7.	Squeeze sensor mounting tabs to release sensor from bracket	

Replacement Procedure (mounting)

1.	Install new sensor onto bracket
2.	Install bracket
3.	Reconnect PS7P connector
4.	Reinstall ejection cover hinge strap screw
5.	Close all covers

6-8.16. Ejection Tray - Paper Path Stacker Full Sensor

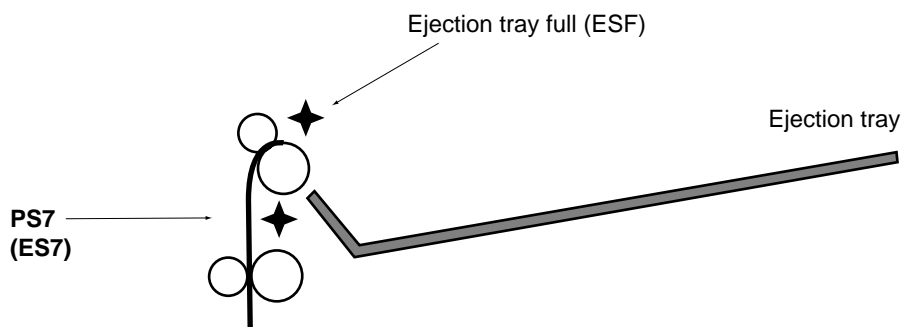

Figure 6-33. Stacker Full Positioning Overview

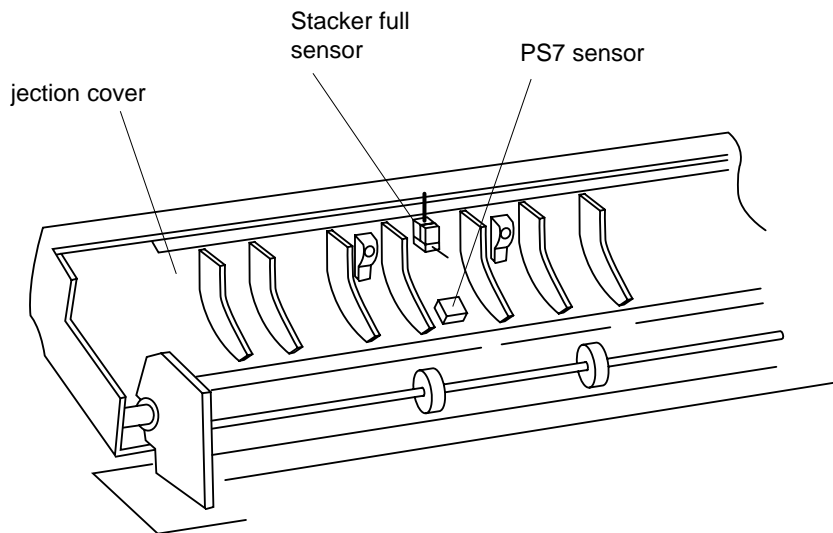

Figure 6-34. Ejection Tray - Paper Path Stacker Full Sensor

Ejection Tray - Paper Path Stacker Full Sensor Replacement Procedure

Part Number

CA02951-5075

Tools Required

Magnetized 8-inch, number-2 Phillips-head screwdriver

Replacement Procedure (removal)

Step	Instruction	Comment
1.	Open upper-left ejection cover	
2.	Open upper-right cover	
3.	Remove top cover	
4.	<p style="text-align: center;">CAUTION</p> <p>Do not put any weight on ejection unit cover when it is not held with the strap hinge</p> <p>Remove bottom flat hinge strap mounting screw and fully open ejection cover</p>	
5.	Follow sensor cable down (and free from cable clamp) to connector board and then disconnect STFLJ connector	
6.	Remove sensor bracket mounting screw	
7.	Squeeze sensor mounting tabs to release sensor from bracket	

Replacement Procedure (mounting)

1. Install new sensor into bracket
2. Install bracket with screw
3. Install cable into cable clamp and reconnect STFLJ connector
4. Reattach cover hinge strap
5. Close all covers

6-9. Left Side of Printer Accessed FRUs

6-9.1. Ejection Unit

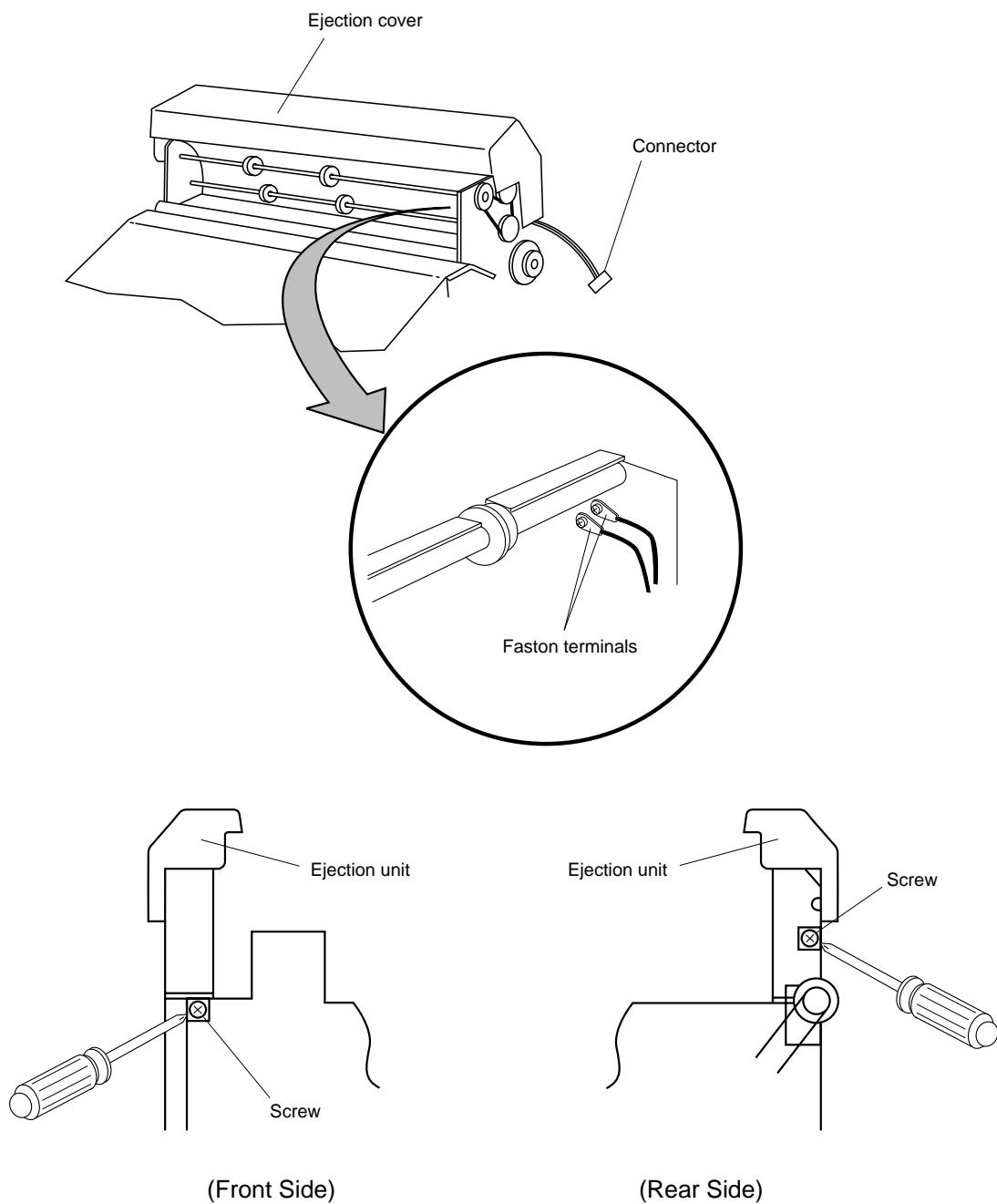

Figure 6-35. Ejection Unit

Ejection Unit Replacement Procedure

Part Number

CA02626-F900

Tools Required

Magnetized 8-inch, number-2 Phillips-head screwdriver

Replacement Procedure (removal)

Step	Instruction	Comment
1.	Open upper-right cover	
2.	Remove rear cover	
3.	Remove top cover	
4.	Remove upper-left cover	
5.	Remove reversing unit Page 6-103	
6.	Remove operator panel and set aside Page 6-29	
7.	On ejection unit, disconnect 2 faston terminals	
8.	Remove 3 mounting screws from both ends and lift unit out	

Replacement Procedure (mounting)

1. Insert new unit
2. Secure unit with 3 screws at each end
3. Attach 2 faston terminals
4. Reinstall operator panel
Page 6-29
5. Reinstall reversing unit
Page 6-103
6. Close all covers

6-9.2. Reversing Unit

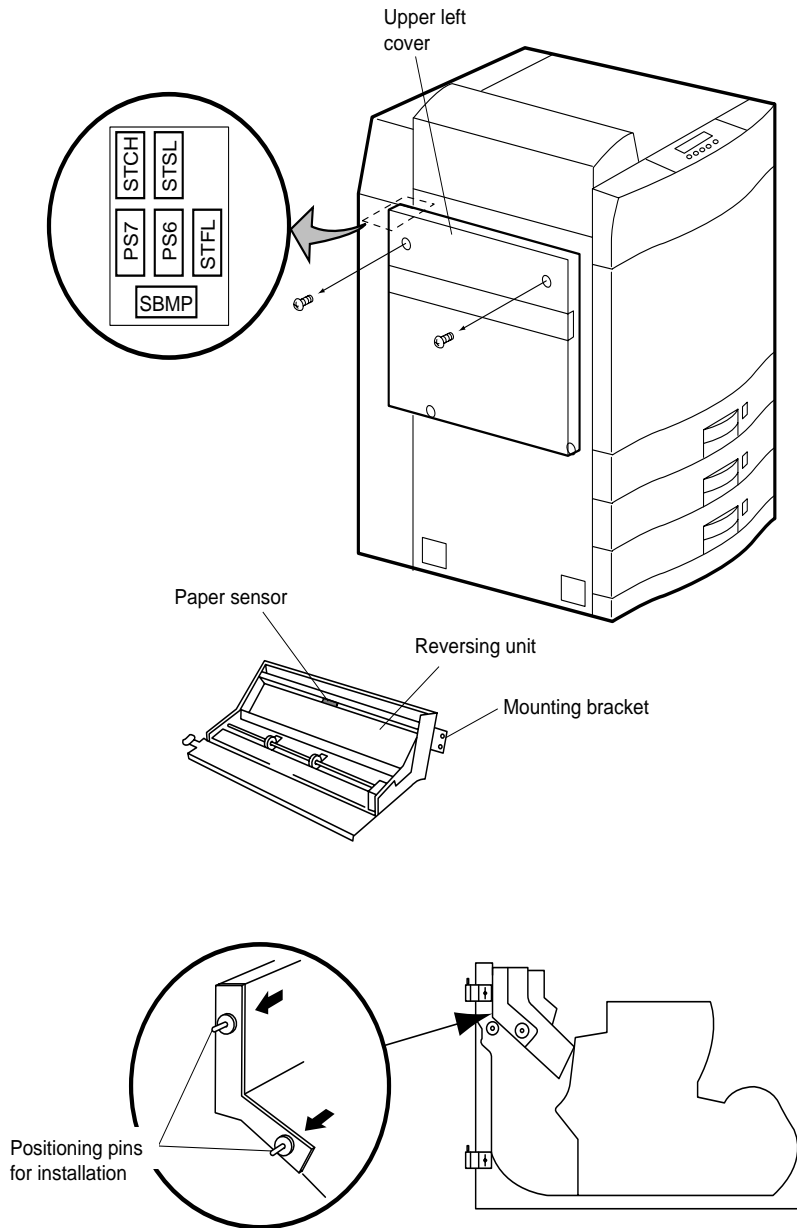

Figure 6-36. Reversing Unit

Reversing Unit Replacement Procedure

Part Number

CA02626-F800

Tools Required

Magnetized 8-inch, number-2 Phillips-head screwdriver

Replacement Procedure (removal)

Step	Instruction	Comment
1.	Open upper-right cover	
2.	Open front door	
3.	Remove rear cover	
4.	Remove upper-left cover	
5.	Remove top cover	
6.	Disconnect connectors SBMP, PS7, PS6, STFL, STCH, and STSL	Located just above the HVPS board
7.	Remove 2 reversing unit mounting screws	Access through left side opening
8.	Carefully pass all cables and connectors through cable hole	As you are pulling the unit to the right

Replacement Procedure (mounting)

1.	Insert the new unit into position	Carefully guide the cables and connectors
2.	Insert the unit positioning pins into guide holes	
3.	Secure unit with 2 screws	
4.	Reconnect connectors STSL, STCH, STFL, PS6, PS7, and SBMP	
5.	Close all covers	

PS6 - Reversing Unit Paper Path Sensor Replacement Procedure**Part Number**

CA55003-1612

Tools Required

Magnetized 8-inch, number-2 Phillips-head screwdriver

Replacement Procedure (removal)

Step	Instruction	Comment
1.	Remove reversing unit Page 6-103	
2.	Remove sensor bracket mounting screw	
3.	Disconnect sensor connector PS6P	
4.	Squeeze sensor mounting tabs to release sensor from bracket	

Replacement Procedure (mounting)

1. Install new sensor onto bracket
2. Install bracket
3. Reconnect PS6P connector
4. Reinstall reversing unit
Page 6-103

6-0. Right Side of Printer Accessed FRUs

6-0.1. Toner Hopper Assembly

Table 6-9. Toner Hopper Assembly

Toner Hopper Assembly Replacement Procedure

Part Number

CA02626-E240

Tools Required

Magnetized 8-inch, number-2 Phillips-head screwdriver

Replacement Procedure (removal)

Step	Instruction	Comment
1.	Open upper-right cover	
2.	Remove rear cover	
3.	Open front door	
4.	Remove top cover	
5.	Remove operator panel Page 6-29	
6.	Remove developer unit Page 6-111	
7.	Remove toner collector bottle and cap	
8.	At toner hopper housing:	
a.	Detach the clamped-on hose plug and remove 2 hose mounting screws	This is where the white hose enters the hopper
b.	At the toner slide control, slide into close position	
c.	Remove 2 bracket screws to free the white hose assembly	
d.	Attach the hose plug over the open hose end	NOTE - If plug is missing, wrap material over the hose and secure
9.	Disconnect inline connector TEMP	
10.	Disconnect toner motor connector TM	
11.	Remove front side 3 screws and top-side 1 screw Page 7-10 Carefully lift hopper out	Do not tip hopper over

Replacement Procedure (mounting)

1. Install new hopper and secure with 4 screws

2. Connect TEMP and TM connectors
3. Reinstall toner hopper hose Reverse step 8 substeps
4. Uncap toner bottle, secure cap in holder, and reinstall
5. Reinstall developer unit
Page 6-111
6. Reinstall operator panel:
Page 6-29
7. Close all covers

6-0.2. Input Power Circuit Breaker

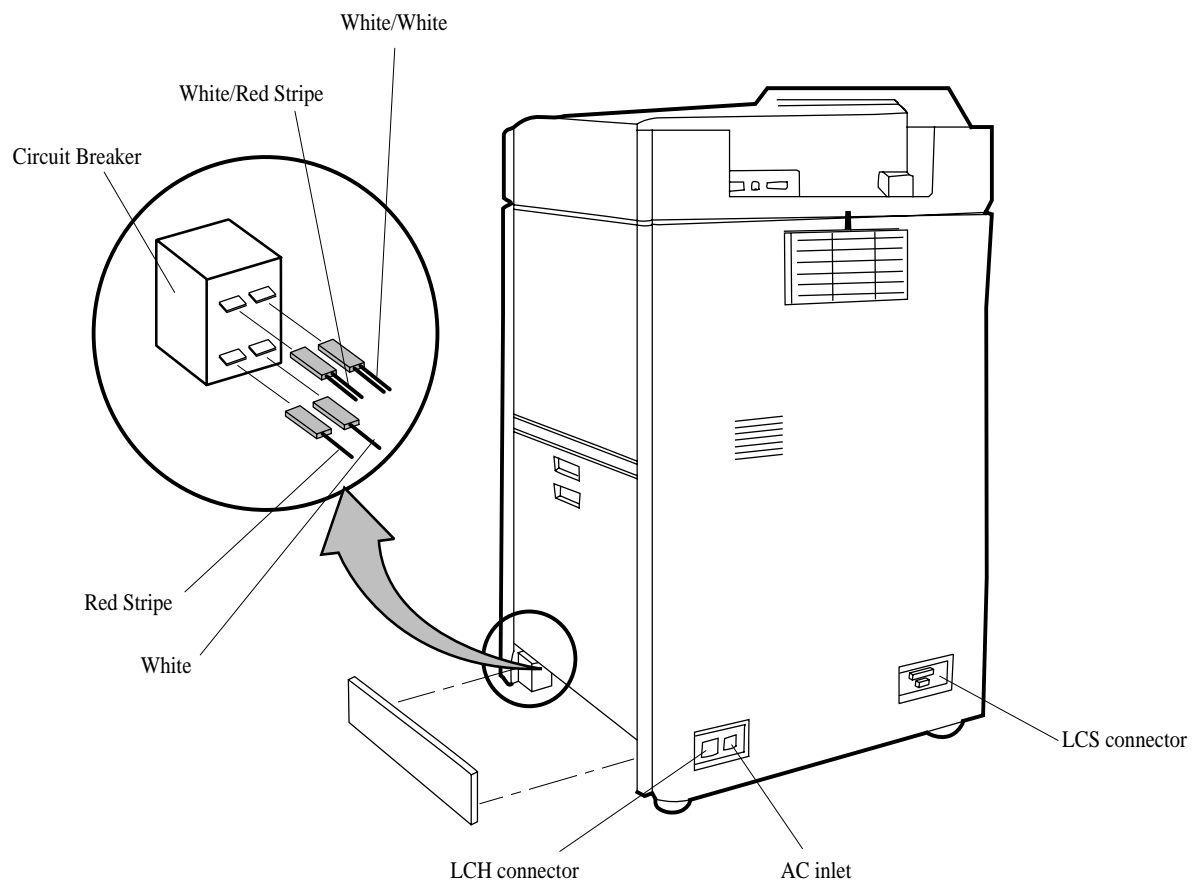

Figure 6-0. Input Power Circuit Breaker

Input Power Circuit Breaker Replacement Procedure

Part Number

CA02626-E049

Tools Required

Magnetized 8-inch, number-2 Phillips-head screwdriver

Replacement Procedure (removal)

Step	Instruction	Comment
1.	Remove 2 lower paper supply trays	Keep track of middle and bottom tray sequence
2.	Loosen 2 center decorative panel mounting screws and remove panel	
3.	Remove 2 screws from bottom-right panel	Covers circuit breaker
4.	Disconnect 4 faston terminals from the circuit breaker	
5.	Remove breaker mounting bracket screw	

Replacement Procedure (mounting)

1. Attach the bracket to frame
2. Reattach wires:
 - a. Inside top - White/white
 - b. Inside bottom - White
 - c. Outside top - White/red stripe
 - d. Outside bottom - Red stripe
3. Reattach circuit breaker cover
4. Reattach lower front cover
5. Reinstall paper supply trays

6-0.3. Developer Unit

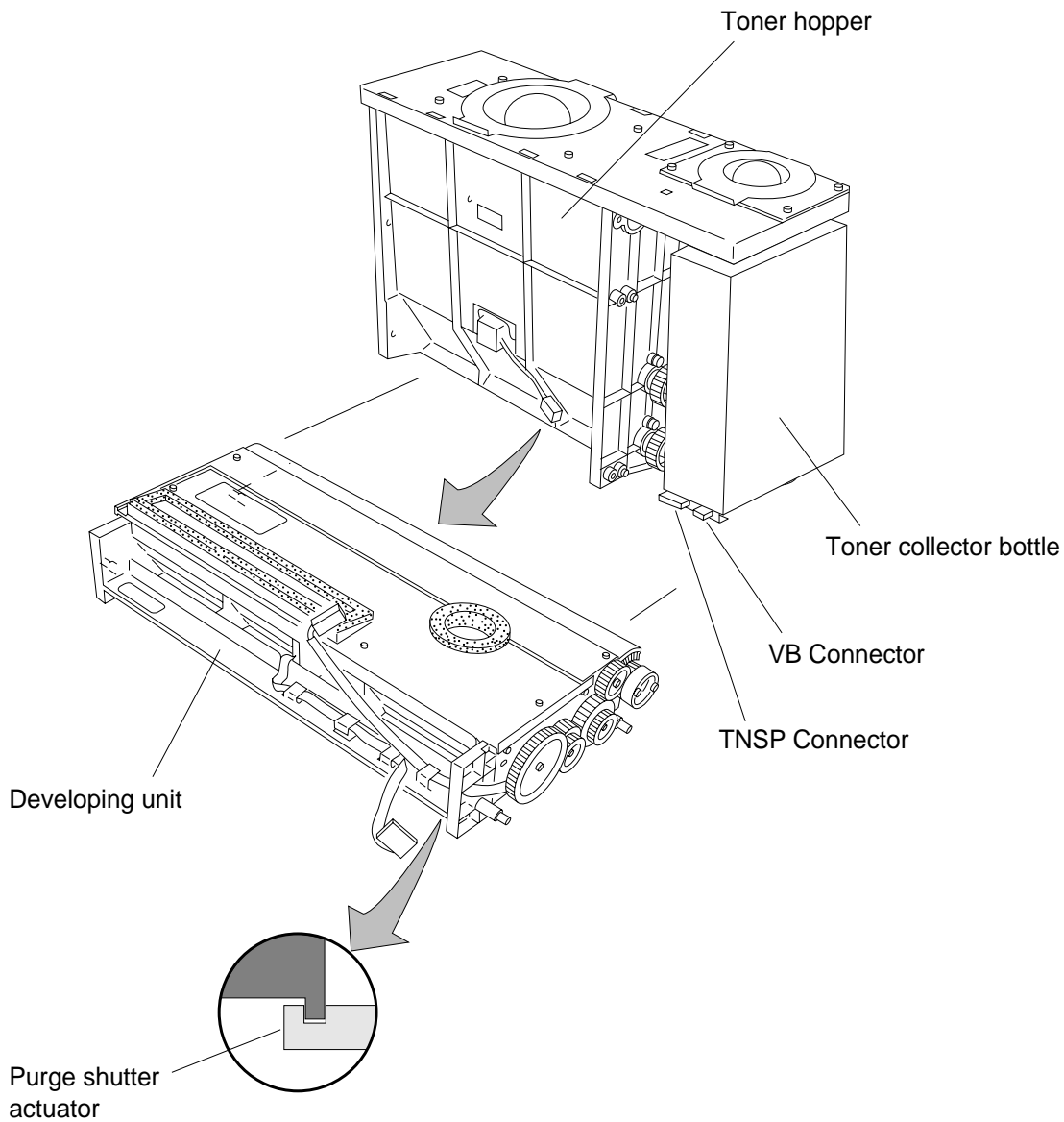

Figure 6-1. Developer Unit

Developer Unit Replacement Procedures

Part Number

CA02626-E200

Tools Required

Magnetized 8-inch, number-2 Phillips-head screwdriver

Replacement Procedure (removal)

Step	Instruction	Comment
1.	Open upper-right cover	
2.	Open front door	
3.	Remove developer collector bottle, cap, and set aside	Located below toner collector bottle
4.	Disconnect connectors TNSP and VB	Located on toner bottle shelf
5.	At upper-right cover left side, remove flat hinge strap securing screw	While facing printer right side
6.	Remove 1 screw Page 7-6	

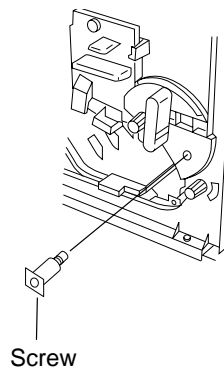

7.	Rotate lever to page 7-10 position	
----	------------------------------------	--



8. Pull out developer unit and set aside Do not tip over

Replacement Procedure (mounting)

1. **CAUTION -**
Locate the slotted actuator rod just below cable connectors (TNSP and VB)

Line up the unit right vertical edge with the slot and slide new unit into place
2. Attach hinge strap
3. Connect cable connectors
4. Uncap developer bottle and slide into place
5. Close all covers

6-0.4. Paper Feed Unit

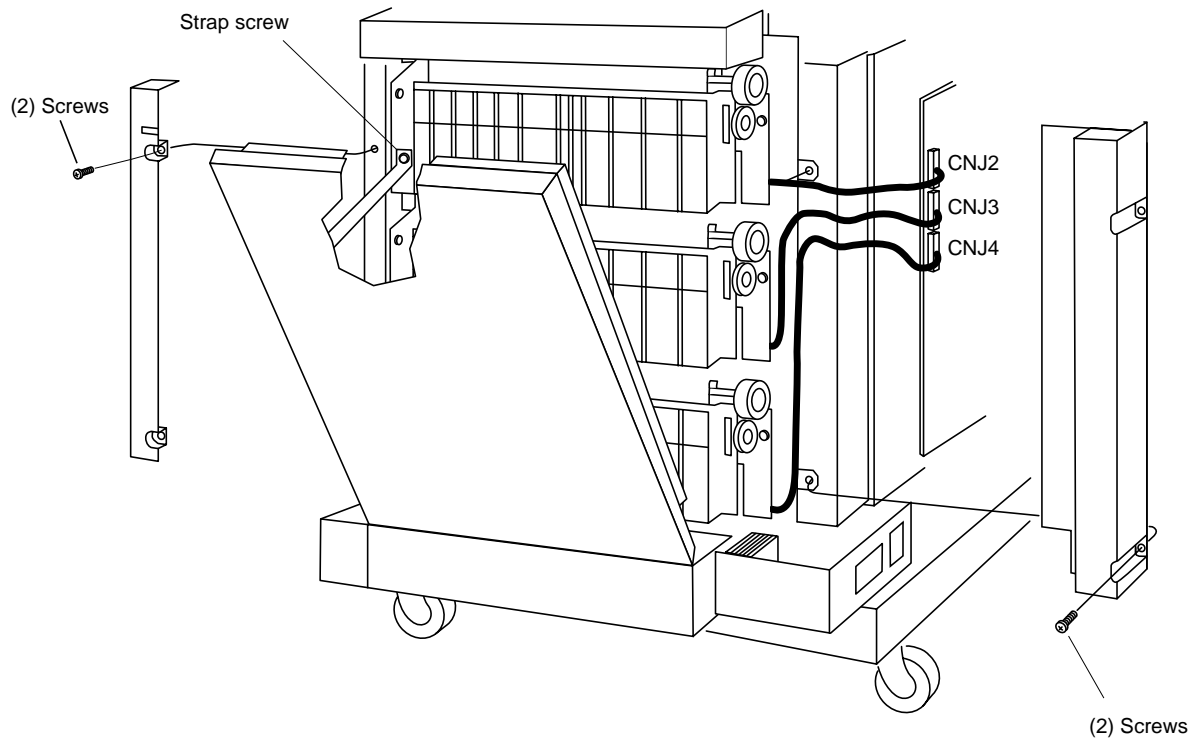

Figure 6-2. Paper Feed Unit

Paper Feed Unit Replacement Procedure

Part Number

CA02626-E330 (Upper and middle units)

CA02626-E331 (Lower unit)

Tools Required

Magnetized 8-inch, number-2 Phillips-head screwdriver

Replacement Procedure (removal)

NOTE

Lower unit is slightly different than the top and middle units. They are not interchangeable.

Step	Instruction	Comment
1.	Open front door	
2.	If installed, slide back the LCH	Attached on movable guides
3.	Remove 3 paper supply trays	Keep track of top, middle, and bottom tray
4.	Remove lower-right cover:	
a.	Remove 2 screws holding decorative cover on left frame support column	
b.	Remove 2 screws holding decorative cover on right frame support column	
c.	<p style="text-align: center;">CAUTION</p> <p>Do not let cover drop down.</p> <p>Remove left side flat hinge strap screw and carefully lay cover down</p>	Facing left side of printer
d.	Remove left side cover hinge plate screw and release cover from both brackets	<p style="text-align: center;">CAUTION</p> <p>Do not lose 2 hinge-pin spacers.</p>
5.	Locate failed paper feed unit	Top, middle, or bottom
6.	On mechanism controller board, disconnect associated unit connector and detach from cable clamp	Top - CNJ2 Middle - CNJ3 Bottom - CNJ4
7.	Press on the tensioner spring and lift belt off pulley	

8. At failed unit, remove 2 mounting screws
9. Carefully lift off holding pins to remove the failed unit

NOTE - Remember the unit cable routing to prevent cable pinching later

CAUTION

Do not damage the belt when removing unit

Replacement Procedure (mounting)

1. Install new unit onto holding pins

2. **CAUTION**

Do not pinch wires.

Top - CNJ2
Middle - CNJ3
Bottom - CNJ4

Route cable to mechanism board and connect

3. **CAUTION**

Do not allow belt to touch any wires.

Reattach drive belt

4. Tighten tensioner bracket

5. Reattach lower cover:

- a. Install spacer washers on hinge pins
- b. Insert hinge pins into hinge brackets
- c. Install hinge bracket screw
- d. Install flat strap with mounting screw

6. Install left and right decorative covers

7. Install all paper trays

In correct sequence

8. Perform *Paper Feed System Alignment*
Page 6-20

9. Close all covers

10. If applicable, reattach LCH

6-0.5. PS1 - Paper Path Sensors (PS1-1, -2, and -3)

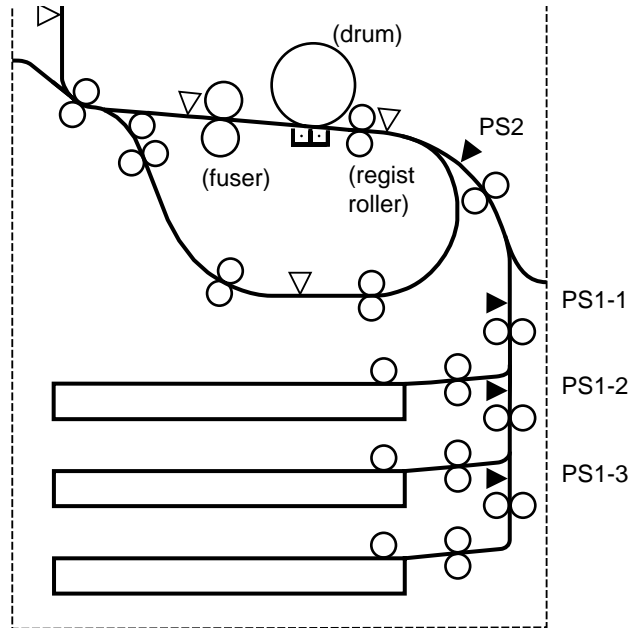

Figure 6-3. PS1 Positioning Overview

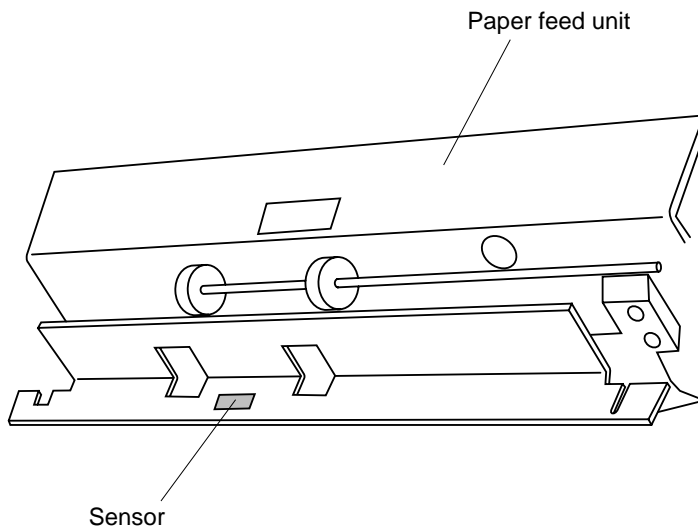

Figure 6-4. Paper Path Sensors PS1-1, -2, and -3

PS1 - Paper Path Sensors Replacement Procedure

Part Number

CA50100-1610

Tools Required

Magnetized 8-inch, number-2 Phillips-head screwdriver

Replacement Procedure (removal)

Step	Instruction	Comment
1.	Remove paper feed unit Page 6-114	
2.	At failed feed unit, remove 2 mounting screws and detach paper guide	
3.	Disconnect sensor connector PS1-1 Top PS1-2 Middle PS1-3 Bottom	
4.	Squeeze sensor tabs to release failed sensor	

Replacement Procedure (mounting)

1.	Install new sensor
2.	Reconnect: PS1-1 Top PS1-2 Middle PS1-3 Bottom
3.	Reattach paper guide
4.	Reinstall paper feed unit Page 6-114

6-0.6. PS2 - Paper Path Timing Sensor

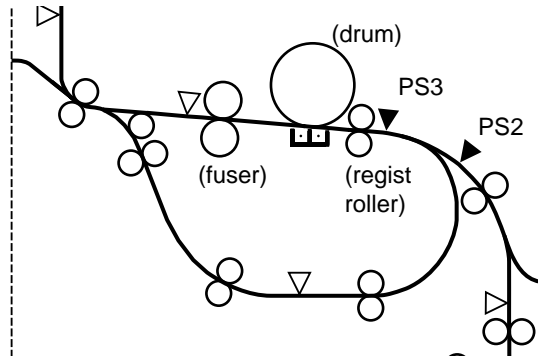

Figure 6-5. PS2 Positioning Overview

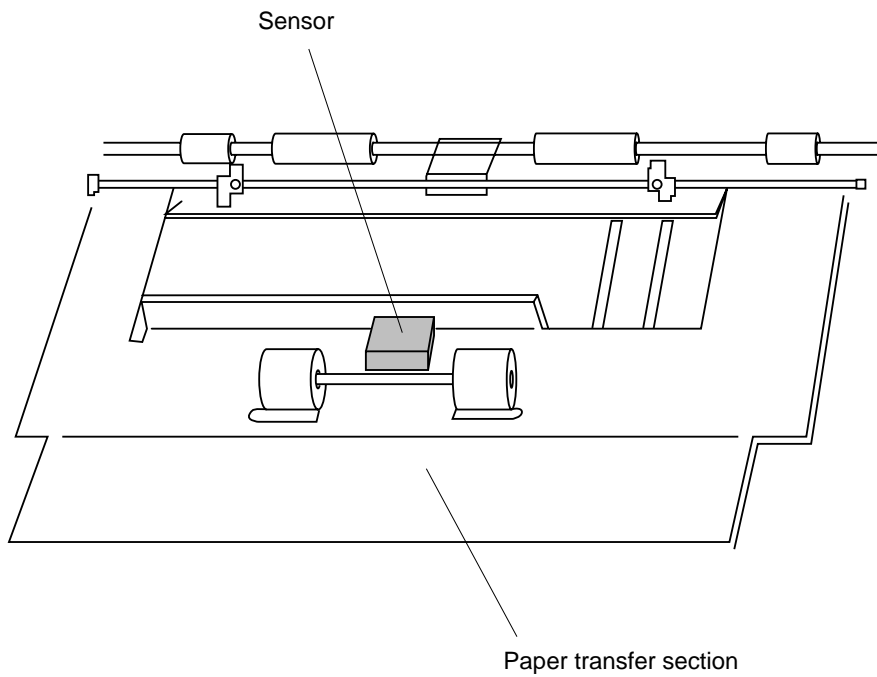

Figure 6-6. Paper Path Timing Sensor PS2

PS2 - Paper Path Timing Sensor Replacement Procedure

Part Number

CA55003-1611

Tools Required

Magnetized 8-inch, number-2 Phillips-head screwdriver

Replacement Procedure (removal)

Step	Instruction	Comment
1.	Remove developer unit Page 6-111	
2.	Remove toner collector bottle	
3.	Remove 2 sensor cover mounting screws and remove cover	
4.	Disconnect PS2J connector	
5.	Squeeze sensor mounting tabs to remove sensor	

Replacement Procedure (mounting)

1.	Install sensor	
2.	Reconnect PS2J connector	
3.	Install sensor cover	
4.	Install toner collector bottle	
5.	Install developer unit Page 6-111	

6-0.7. PS3 - Paper Path Registration Sensor

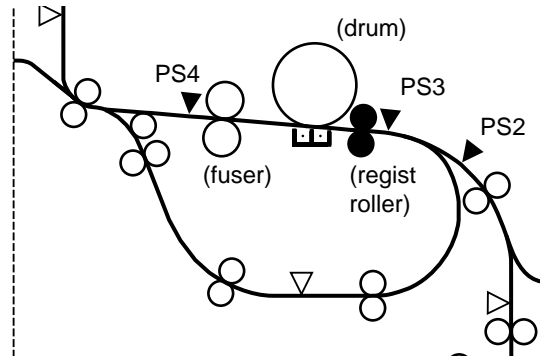

Figure 6-7. PS3 Positioning Overview

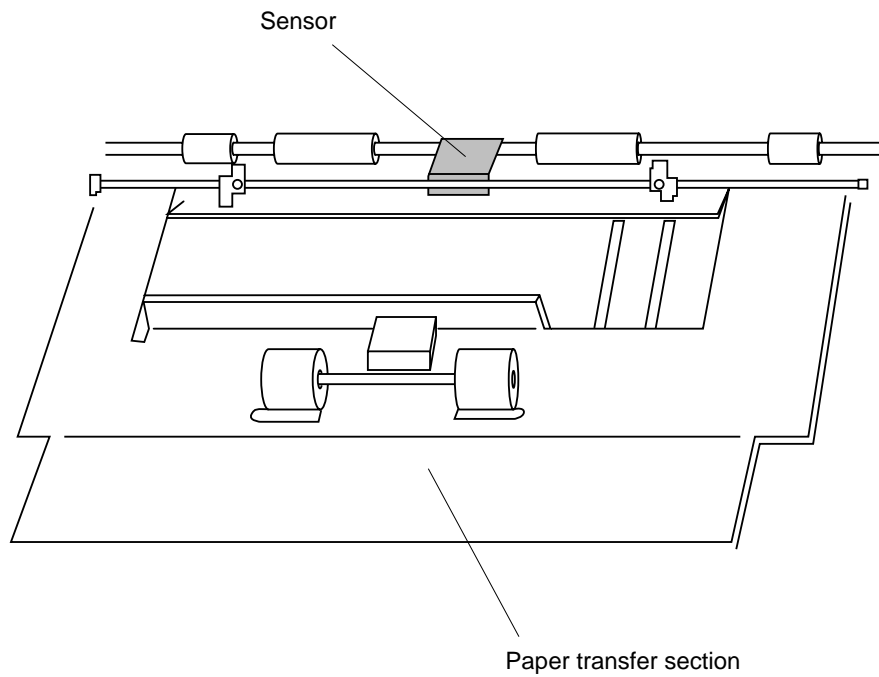

Figure 6-8. Paper Path Registration Sensor PS3

PS3 - Paper Path Registration Sensor Replacement Procedure

Part Number

CA550003-1627

Tools Required

Magnetized 8-inch, number-2 Phillips-head screwdriver

Replacement Procedure (removal)

Step	Instruction	Comment
1.	Remove developer unit Page 6-111	
2.	Remove toner collector bottle	
3.	Remove 2 sensor cover mounting screws and remove cover	
4.	Disconnect PS3J connector	
5.	Squeeze sensor mounting tabs to remove sensor	

Replacement Procedure (mounting)

1.	Install sensor	
2.	Reconnect PS3J connector	
3.	Install sensor cover	
4.	Install toner collector bottle	
5.	Install developer unit Page 6-111	

6-0.8. PS4 - Paper Path De-curling Sensor

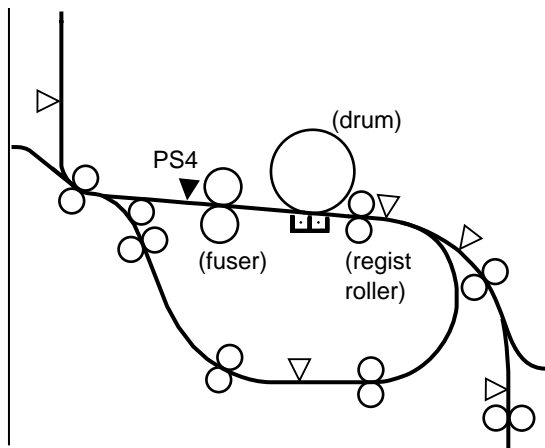

Figure 6-9. PS4 Positioning Overview

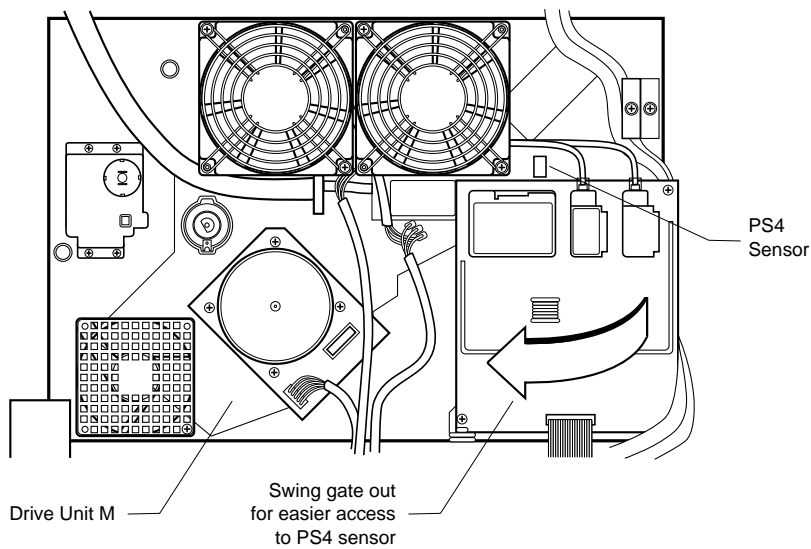

Figure 6-10. Paper Path De-curling Sensor PS4

PS4 - Paper Path De-curling Sensor Replacement Procedure

Part Number

B86L-2410-0822A

Tools Required

Magnetized 8-inch, number-2 Phillips-head screwdriver

Replacement Procedure (removal)

Step	Instruction	Comment
1.	Open front door	
2.	Remove fuser unit	
3.	Open upper-right cover	
4.	Remove top cover	
5.	Remove rear cover	
6.	Remove 3 screws securing gray plastic top shield	
7.	Disconnect lower HVPS connectors CN1 and CNDC	
8.	Remove 2 screws securing HVPS bracket and swing bracket out	
9.	Disconnect PS4J connector	
10.	Remove PS4 bracket holding screw	Screwdriver pointing downward
11.	Remove knob screw on knob of de-curling roller	
12.	Remove screw located just above knob shaft	Just below laser warning label
13.	Carefully reach in, grasp PS4 sensor, and then slightly twist and push in then pull out	
14.	Squeeze sensor tabs to free from bracket	

Replacement Procedure (mounting)

- 1. Install new sensor into bracket

2.

CAUTION

Observe the bracket and locate the 2 positioning-pin holes. When installed, the positioning pins must be properly seated into the holes.

Install the bracket with the positioning pins properly seated

3.

From the top, reinstall bracket holding screw

Verify positioning pin placement

4.

Reconnect PS4J connector

5.

Close and secure HVPS bracket

6.

Reconnect lower HVPS connectors CN1 and CNDC

7.

Reinstall plastic shield

8.

Reinstall front screw above de-curling shaft

9.

Reinstall de-curling knob

10.

Reinstall fuser unit

11.

Close all covers

6-0.9. Paper Feed Unit Transport Feed Motor

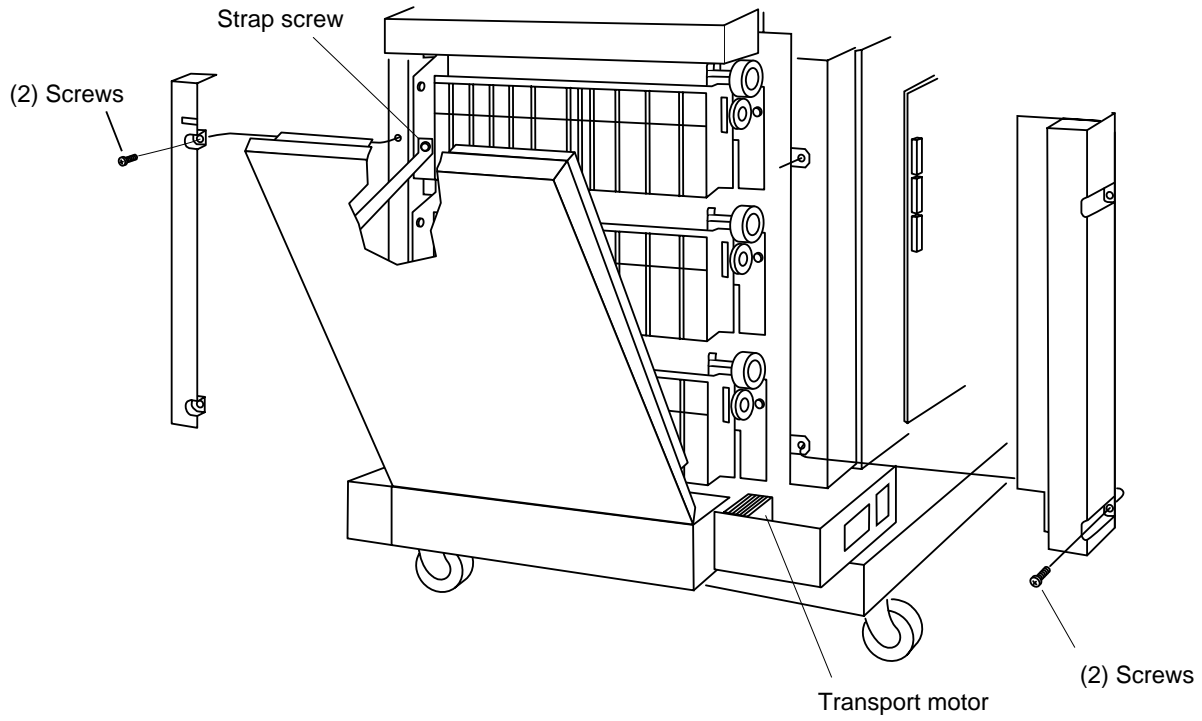

Figure 6-11. Paper Feed Unit Transport Feed Motor

Paper Feed Unit Transport Feed Motor Replacement Procedure

Part Number

CA02626-E441

Tools Required

Magnetized 8-inch, number-2 Phillips-head screwdriver

Replacement Procedure (removal)

Step	Instruction	Comment
1.	Open front door	
2.	If installed, slide back the LCH	Attached on movable guides
3.	Remove 3 paper supply trays	Keep track of top, middle, and bottom trays
4.	Remove lower-right cover:	
a.	Remove 2 screws holding decorative cover on left frame support column	
b.	Remove 2 screws holding decorative cover on right frame support column	
c.	<p style="text-align: center;">CAUTION</p> <p>Do not let cover drop down.</p> <p>Remove left side flat hinge strap screw and carefully lay cover down</p>	Facing left side of printer
d.	Remove left side cover hinge plate screw and release cover from both brackets	<p style="text-align: center;">CAUTION</p> <p>Do not lose 2 hinge-pin spacers.</p>
5.	From the rear, loosen the tensioner bracket screw	
6.	Press on the tensioner spring and lift belt off pulley	
7.	Temporarily, retighten the bracket screw	
8.	Loose 3 screws AC inlet bracket are attached, and move the bracket to remove motor bracket screws	
9.	Disconnect motor cable connector FMP	
10.	Remove 2 motor mounting bracket screws and remove assembly	
11.	Remove 3 motor mounting screws	

Replacement Procedure (mounting)

1. Mount new motor onto bracket

2. Mount motor bracket assembly
3. Connect FMP connector
4. Loosen tensioner bracket screw and reinstall belt over motor gear and tensioner
5. Tighten tensioner bracket
6. Reattach lower cover:
 - a. Install spacer washers on hinge pins
 - b. Insert hinge pins into hinge brackets
 - c. Install hinge bracket screw
 - d. Install flat strap with mounting screw
7. Install side-column covers
8. Install all paper trays In correct sequence
9. Close all covers
10. If applicable, reattach LCH

6-0.10. Registration Roller

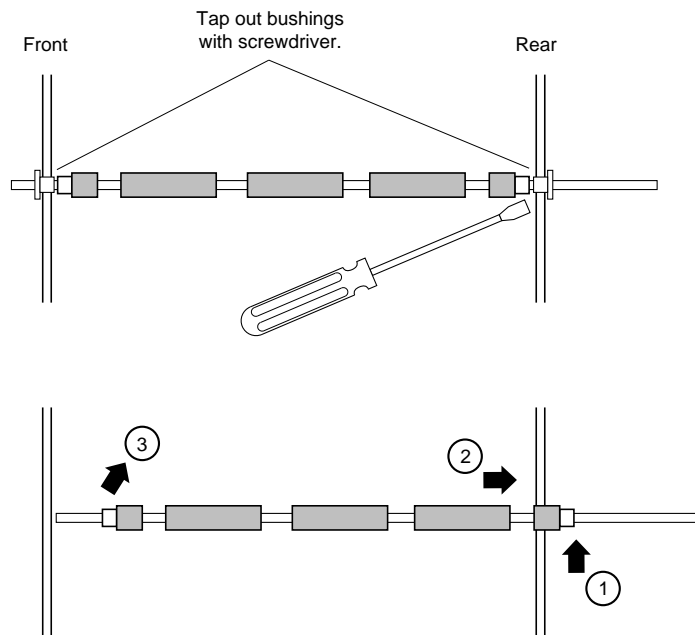
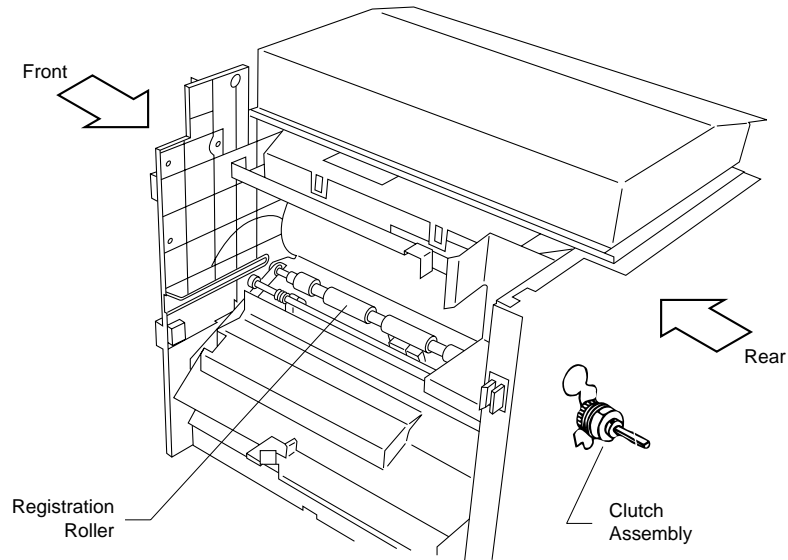

Figure 6-12. Registration Roller Removal

Registration Roller Replacement Procedure

Part Number

CA02626-E147

Tools Required

Magnetized 8-inch, number-2 Phillips-head screwdriver

Replacement Procedure (removal)

Step	Instruction	Comment
1.	Open front door	
2.	Open upper-right cover	
3.	Remove rear cover	
4.	Remove drum unit and set aside	
5.	Remove registration roller standby clutch Page 6-54	
6.	Remove developer unit Page 6-111	
7.	Remove screw from registration roller knob	
8.	From the right side opening, using a small flat blade screw driver, push on the roller shaft front bushing narrow end so that the wide collar end will slide out towards the front	Just light pressure required
9.	Repeat step 8 on the rear bushing to push out to the rear	Figure 6-12
10.	Lift shaft rear end up (1) and pull towards the rear (2) just far enough to free the front shaft end and then pull the shaft forward (3) to free the shaft	See 1 - 2 - 3 sequence callouts on Figure 6-13

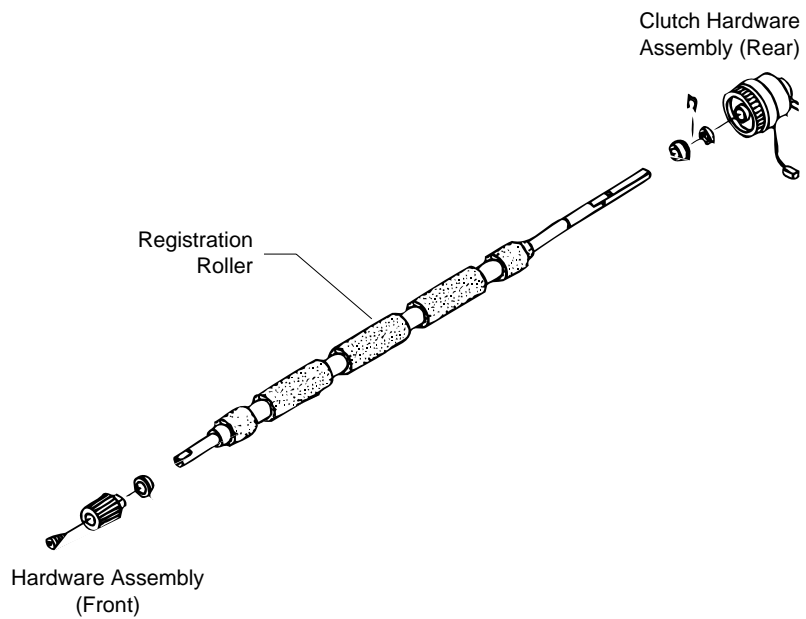

Figure 6-13. Registration Roller Shaft Assembly

Replacement Procedure (mounting)

1. Remove both bushings from the failed roller and examine for wear Verify that the bushings are not damaged
2. Slip on the **rear bushing first** and pass the rear roller shaft end into the rear big hole
3. Pull the shaft back just enough to allow the front end to enter the front hole
4. With the rear bushing pulled back, lower the shaft into the smaller opening Notice that the smaller opening is not round - it has 2 straight edges
5. Align the rear bushing straight edges with the small-hole edges and push bushing into place Patience is required
6. With one hand holding the rear bushing secure, slip on the front bushing and again align the straight edges and push bushing into place
7. While holding roller shaft secure, reinstall the knob
8. Reinstall registration roller clutch Page 6-54
9. Reinstall developer unit
Page 6-111
10. Install drum unit and raise transfer assembly guide
11. Close all covers **except** rear cover
12. Power ON
13. Perform Laser Start Position Alignment
Page 6-18
14. Perform Paper Feed System Alignment
Page 6-20
15. Close rear cover

6-1. Printer Microswitch Locational Diagrams

6-1.1. Developer Unit Collector Bottle Detection Microswitch

Part Number

CA02626-E142

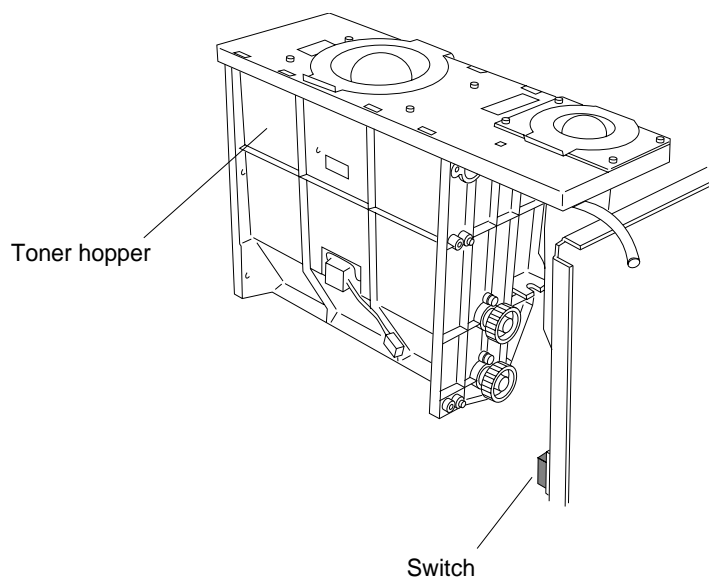

Figure 6-14. Developer Unit Collector Bottle Detection Microswitch

6-1.2. chap6d.frmDeveloper Unit Shutter Detection Microswitch

Part Number

CA02626-E142

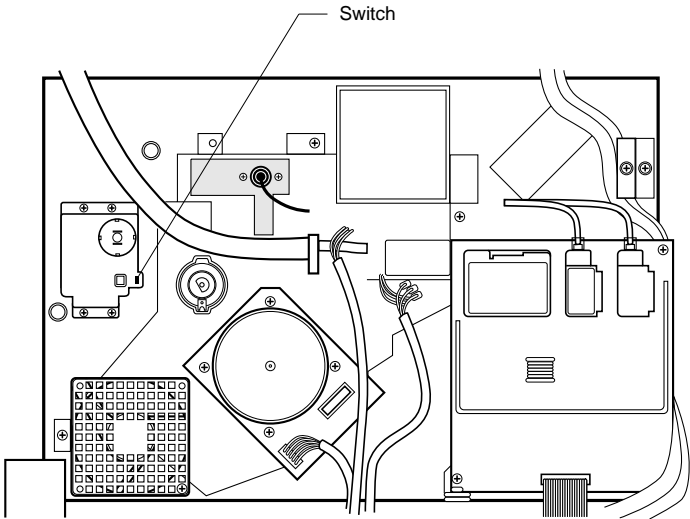

Figure 6-15. Developer Unit Shutter Detection Microswitch

6-1.3. Drum Unit Interlock Switch

Part Number

CA02951-5078

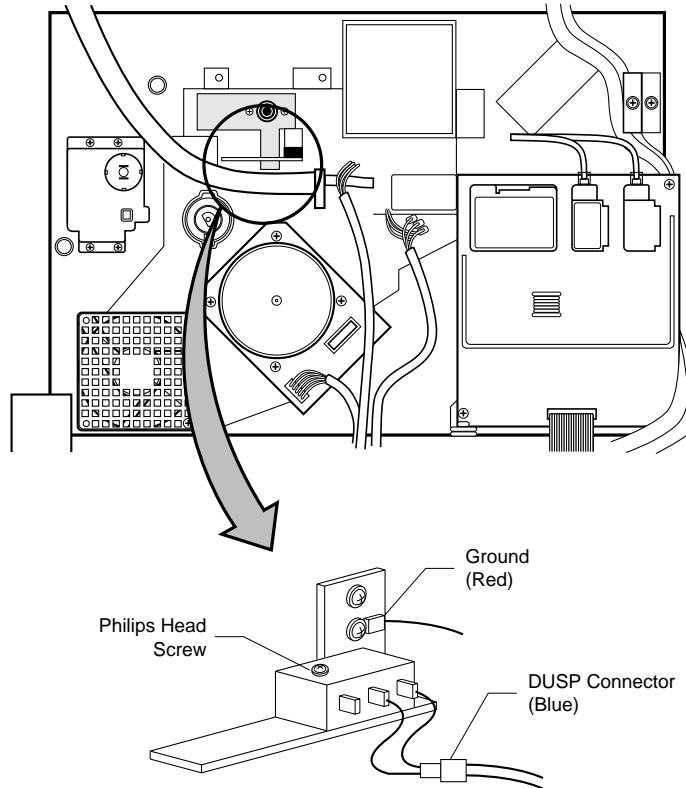

Figure 6-6. Drum Unit Interlock Switch

6-1.4. Ejection Unit Cover Interlock Microswitch

Part Number

CA02626-E142

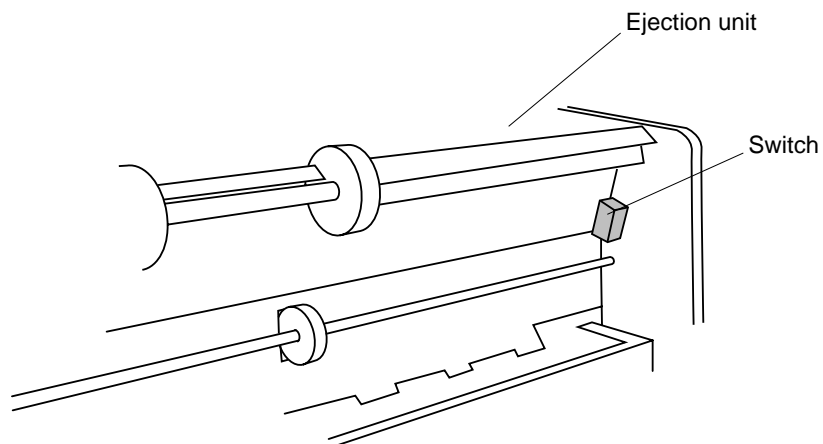

Figure 6-7. Ejection Unit Cover Interlock Microswitch

6-1.5. Front Door Interlock Microswitch

Part Number

CA98001-6946

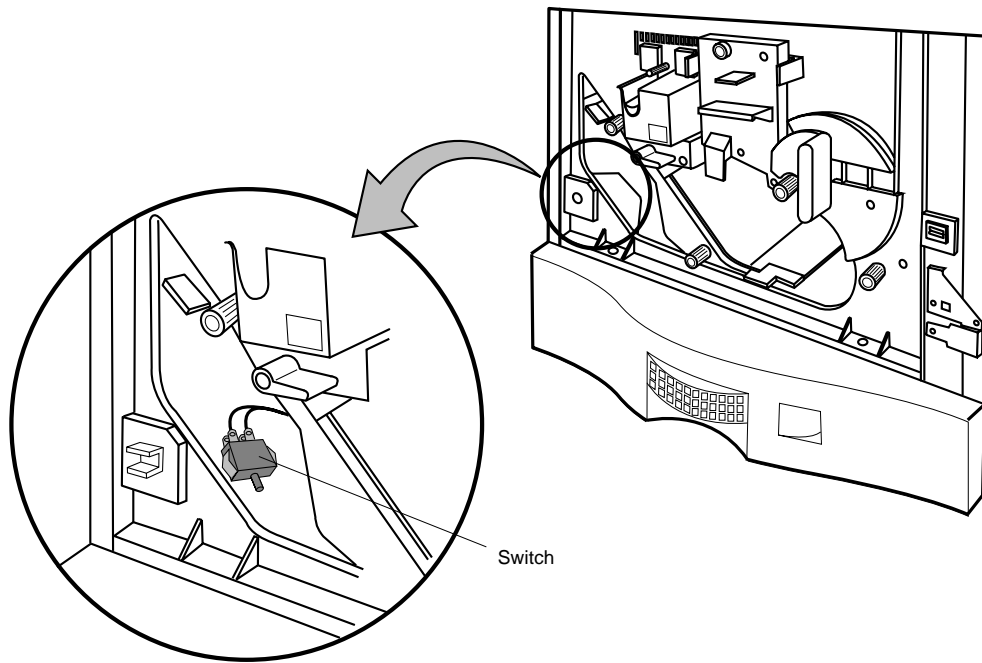

Figure 6-8. Front Door Interlock Microswitch

6-1.6. Paper Tray Detection Microswitch

Part Number

CA02626-E142

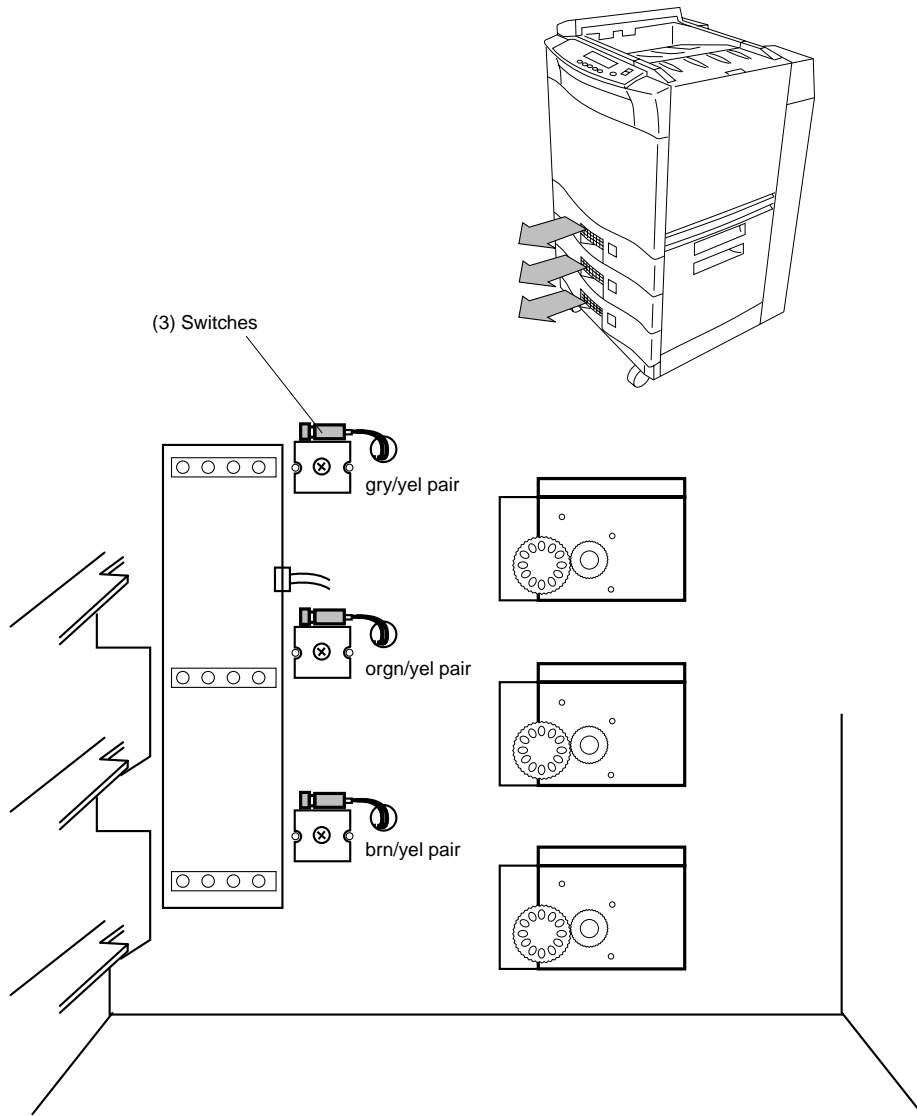

Figure 6-9. Paper Tray Detection Microswitch

6-1.7. Lower-right Cover Interlock Microswitch

Part Number

CA02626-E142

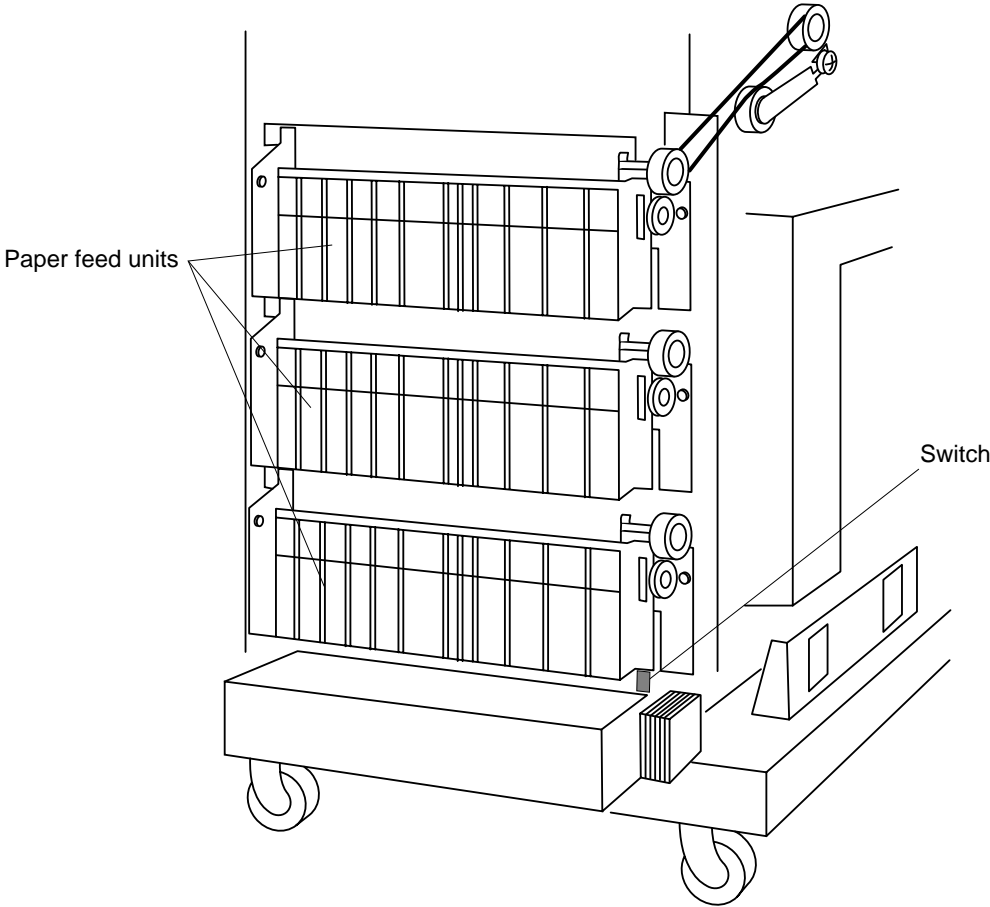

Figure 6-10. Lower-right Cover Interlock Microswitch

6-1.8. Upper-right Cover Interlock Microswitch

Part Number

CA98001-6946

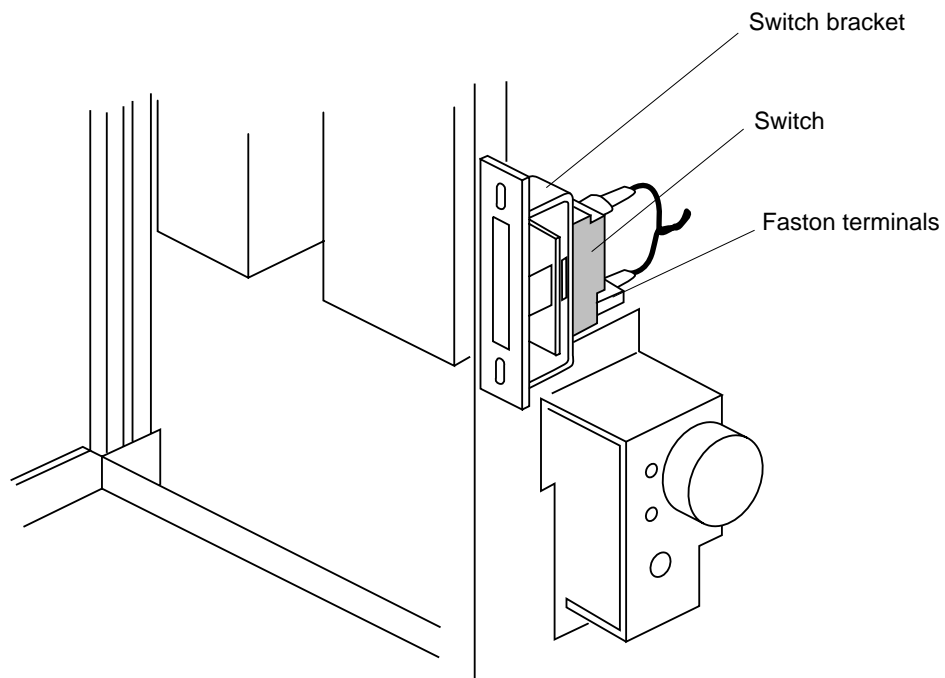

Figure 6-11. Upper-right Cover Interlock Microswitch

6-2. LCH FRUs

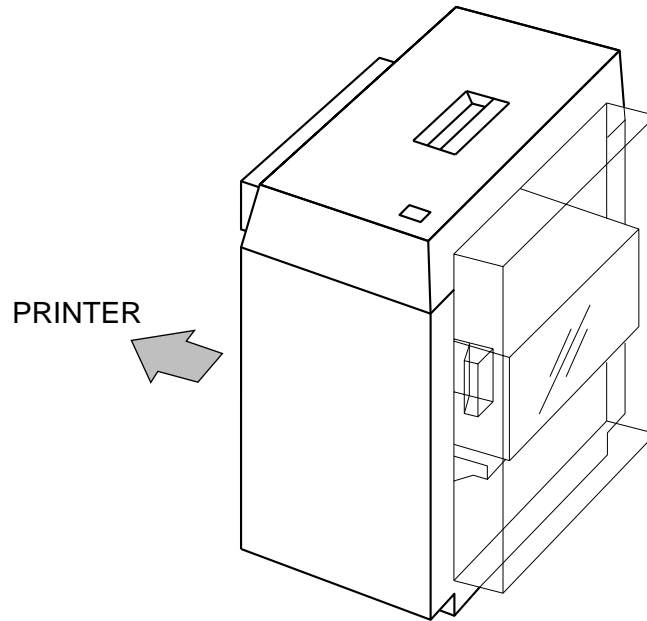

Figure 6-12. LCH Paper Handler

6-2.1. Changing Paper Size of LCH

Tools Required

Magnetized 8-inch, number-2 Phillips-head screwdriver

Procedure

Step	Instruction	Comment
1.	Slide the LCH away from the printer and open the LCH door.	At the time of shipment, LCH bound for metric areas are set for Letter size paper. The elevator should be in its lowered position before carrying out the following procedure.

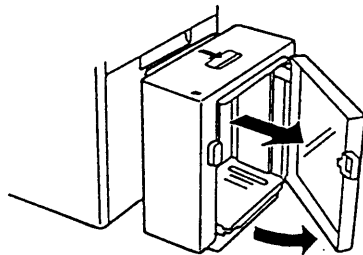

2.	Lifting up the top cover a little, unplug the connector and remove the top cover.
----	---

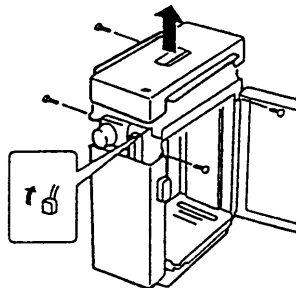

3.	Remove the two screws at the paper edge guides.
----	---

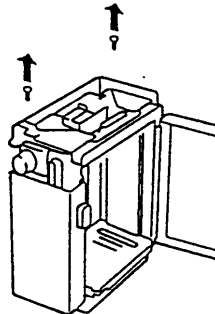

CHAPTER 7 REPLACEABLE PARTS LIST

Section

1-1	Introduction.....	1-3
1-2	Understanding Parts List Heading Descriptions.....	1-3
1-3	Printer Parts Locational Diagrams and Listings.....	1-4
1-3.1	Cover Assemblies.....	1-4
1-3.2	Duplex Unit.....	1-8
1-3.3	Fuser and Drum Units.....	1-10
1-3.4	Transfer Assembly Guide.....	1-12
1-3.5	Paper Trays, Paper Size Sensors, Paper Lift Motor, and Tray Empty Sensor 1-14	
1-3.6	Main Controller and Optical Unit.....	1-16
1-3.7	Ejection Unit and Operator Panel.....	1-18
1-3.8	Reversing Unit.....	1-20
1-3.9	Paper Path Transport Assembly.....	1-22
1-3.10	Paper Feed Unit.....	1-24
1-3.11	Toner Hopper and Developer Units.....	1-26
1-3.12	Main Frame Assembly.....	1-28
1-3.13	Drive Unit M.....	1-30
1-3.14	Mechanism Controller PCB, HVPS, LVPS, and LVPS Fan.....	1-32
1-3.15	Drive Unit D Motor, Drive Unit E, and Drive Unit E Belt.....	1-34
1-4	LCIF Parts Locational Diagrams and Listings.....	1-36
1-4.1	LCIF Frame.....	1-36
1-4.2	Paper Feed Assembly.....	1-38
1-4.3	LCIF Paper Transport.....	1-40
1-5	LCOS Parts Locational Diagrams and Listings.....	1-44
1-5.1	LCOS Attachment Parts.....	1-44
1-5.2	LCOS Stacker Frame.....	1-46
1-5.3	LCOS Controls and Cover Assemblies.....	1-48
1-5.4	LCOS Input-Paper Transport Assembly.....	1-50
1-5.5	LCOS Output-Paper Transport Assembly.....	1-52

MINOLTA-QMS 4060 PARTS MANUAL

7-1. Introduction

This manual gives a breakdown on replaceable parts for the MINOLTA-QMS 4060 printer as well as the optional Large-Capacity Input Feeder (LCIF) and Large-Capacity Output Stacker (LCOS) units. The illustrations give an exploded view of an assembly, and separate parts and how they fit together. Each part has a number corresponding to an Index No. on the parts list.

7-2. Understanding Parts List Heading Descriptions

1. INDEX NUMBER

The number that corresponds with a part's number in the illustration.

2. COMPOSITION and QUANTITY

These columns show the relationship between units, assemblies, and parts.

A unit indicated in a column is assembled of the parts indicated in the next column to the right. The figure is the quantity needed to assemble the part into a higher assembled unit.

3. SPECIFICATION

Part number of the units, assemblies, subassemblies, or parts.

When no part number is given, the part is not a recommended spare part or repair part.

4. DESCRIPTION

The part name, applicable device number, and other information are given in this column.

5. REMARKS

A more descriptive part name, part location, and other information are given in this column.

MINOLTA-QMS 4060 PARTS MANUAL

7-3. Printer Parts Locational Diagrams and Listings

7-3.1. Cover Assemblies

Table 7-1. Cover Assemblies Parts Listing (1/2)

Index No.	Composition and Quantity				Specification	Description	Remarks
1	1					Printer Unit Cover Assembly	
1	1				857CA31214-0200	Top cover	
2		2				Screw	
3		1			857CA98001-3336	Latch, Side Cover	
4		1			857CA31214-0280	Cover, Upper Right	
5		1				Hinge Assembly, L	
6		1				Screw	
7		1				Hinge Assembly, R	
8		1				Screw	
9		1			857CA31214-0418	Strap	
10		2				Screw	
11		1			857CA31214-0417	Strap	
12		2				Screw	
13		1			857CA31214-0380	Cover	
14		2				Screw	
15		1			857CA31214-0340	Base cover, R	
16		2				Screw	
17		1			857CA31214-0330	Base cover, F	
18		2				Screw	
19		1			857CA31214-0350	Base cover, B	
20		2				Screw	
21		1			857CA31214-0370	Cover	
22		2				Screw	
23		1			857CA31214-0270	Front cover	
24		1				Metal fitting	
25		2				Screw	
26		1			857CA31214-0416	Strap	
27		2				Screw	
28		1			857CA31214-E400	Rear cover	
29		1				Screw	
30		1			857CA31214-0300	Left cover	
31		1				Screw	
32		1			857CA31214-0320	Exit vent	
33		1			857CA31214-0360	Base cover, L	
34		2				Screw	
35		2			857CA31214-0390	L cover	
36	1				857CA98001-3336	Latch, Front Cover	

MINOLTA-QMS 4060 PARTS MANUAL

Table 1-1 Cover Assemblies Parts Listing (2/2)

Index No.	Composition and Quantity				Specification	Description	Remarks
37	1				857CA02626-E049	Circuit breaker	
38	1				857CA31214-0415	Holder	
39		2				Screw	Not Shown
40	1					Guide	Not Shown
41		2				Screw	Not Shown
42		1				Screw	Not Shown
43		1				Bracket	Not Shown
44		1				Caster Kit	Not Shown
45		2				Plate Kit	Not Shown
46	1					*1 Ozone Filter	
						*1 - Part of Developer Kit	1710202-001A

MINOLTA-QMS 4060 PARTS MANUAL

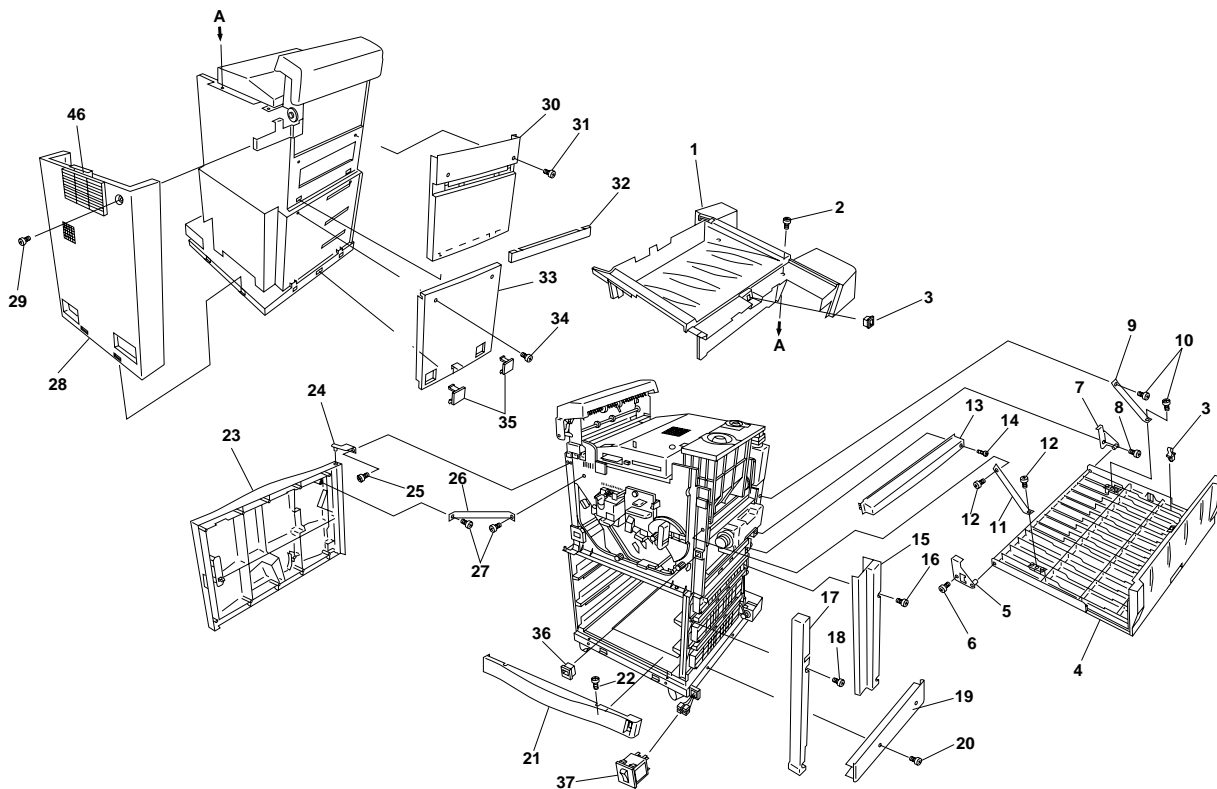

Figure 7-1. Cover Assemblies Parts Locational Diagram

MINOLTA-QMS 4060 PARTS MANUAL

7-3.2. Duplex Unit

Table 7-2. Duplex Unit Parts Listing

Index No.	Composition and Quantity				Specification	Description	Remarks
	1					Mechanism assembly	
1	1				857CA02626-F840	Duplex unit	
2	2				857CA02626-E847	Roller assembly	
3		2				Bearing	
4		1				Spacer	
5		1				Pulley	
6		1				E-ring	
7		1				E-ring	
8	1				857CA02626-E848	Roller assembly	
9		2				Bearing	
10		1				Spacer	
11		1				Pulley	
12		1				E-ring	
13		1				Knob	
14		3				Sheet	
15		1			857CA02626-E846	Motor assembly	
16			1			Pulley	
17			1			Bushing	
18		4				Screw	
19		1			857CA98001-6940	Belt	
20		1			857CA98001-6945	Belt	
21		1			857CA55002-0337	Sensor	PS5
22	2					Screw	
23	1				857CA02626-E867	Plate	
24	2					Screw	

MINOLTA-QMS 4060 PARTS MANUAL

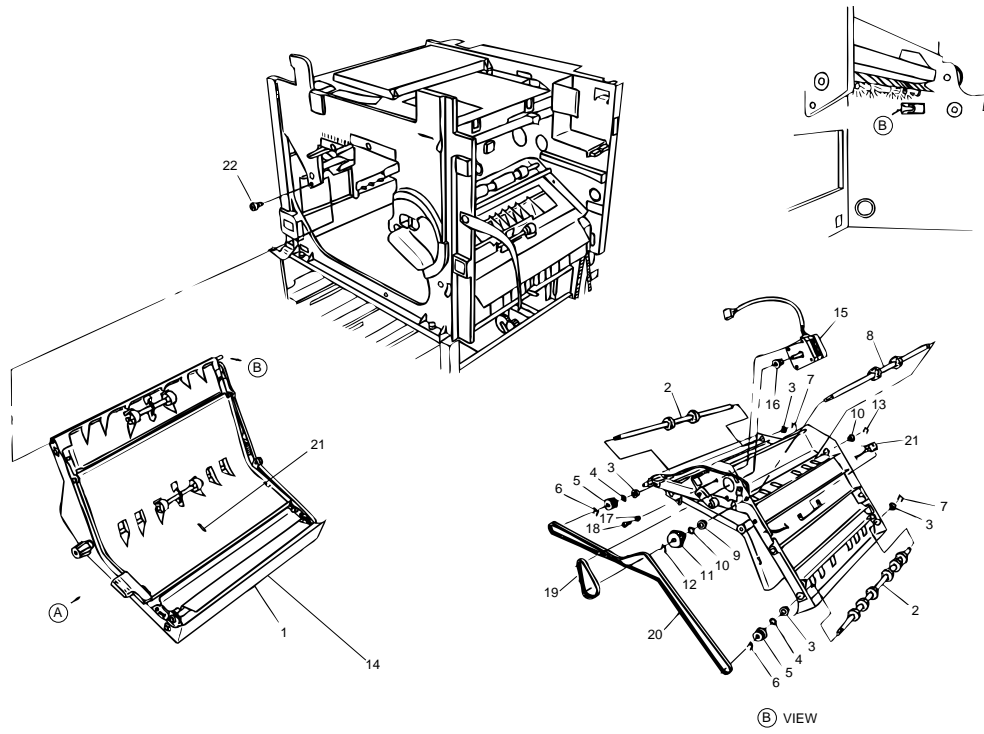

Figure 7-2. Duplex Unit Parts Locational Diagram

MINOLTA-QMS 4060 PARTS MANUAL

7-3.3. Fuser and Drum Units

Table 7-3. Fuser and Drum Units Parts Listing

Index No.	Composition and Quantity				Specification	Description	Remarks
1	1	1			857CA81218-E013 (120-127V) 857CA81218-E014 (200-240V)	Engine assembly *4 Fuser unit	
2			1			*1 Cleaning roller	
3		1			857CA81218-E005	*3 Drum unit	
4		1				*2 Developer	
5		1				*1 Waste Toner Bottle	
						*1 - Part of Toner Kit	1710201-001
						*2 - Part of Developer Kit	1710202-001A
						*3 - Part of Drum Kit	1710203-001A
						*4 - Part of Fuser Kit	1710204-001A

MINOLTA-QMS 4060 PARTS MANUAL

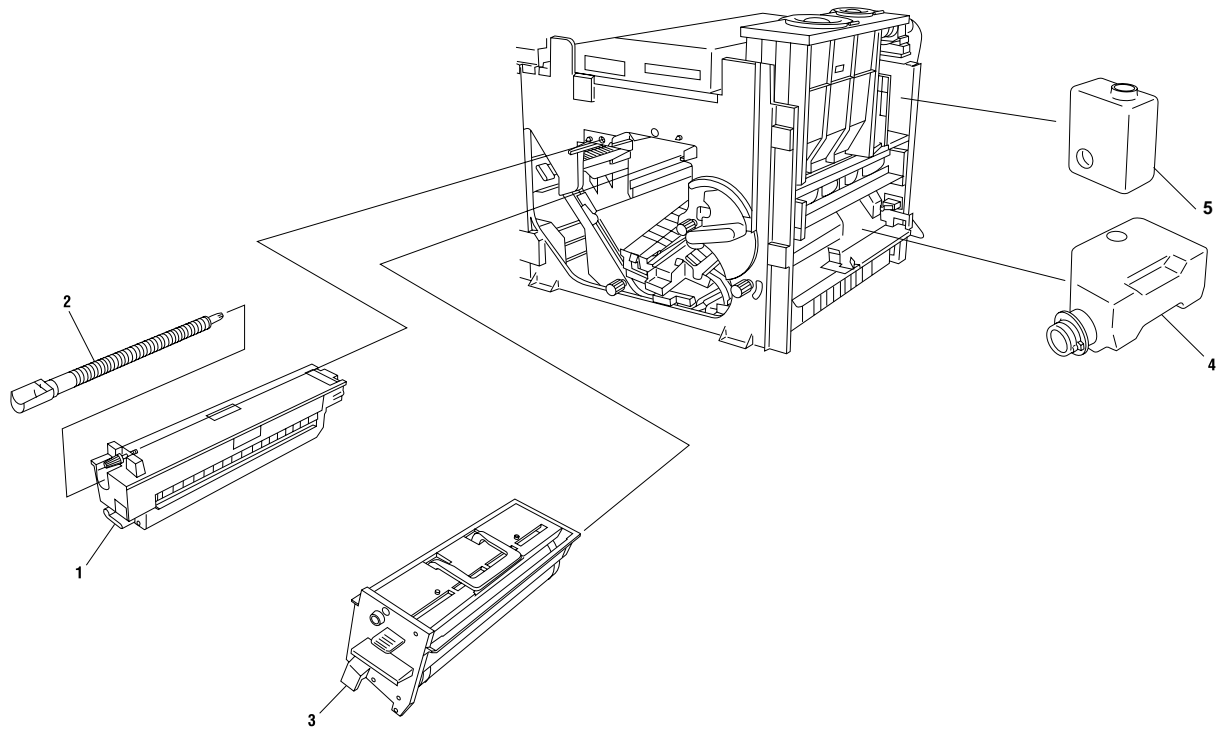

Figure 7-3. Fuser and Drum Unit Parts Locational Diagram

MINOLTA-QMS 4060 PARTS MANUAL

7-3.4. Transfer Assembly Guide

Table 7-4. Transfer Guide Assembly Parts Listing

Index No.	Composition and Quantity				Specification	Description	Remarks
	1					Mechanism assembly	
1		1			857CA04267-E501	Transfer unit guide	
2		1			857CA81218-E093	*1 Transfer unit	
3		1				Block	
4		1				Block	
5						FG Cable	
						*1 - Part of Drum Kit	1710203-001A

MINOLTA-QMS 4060 PARTS MANUAL

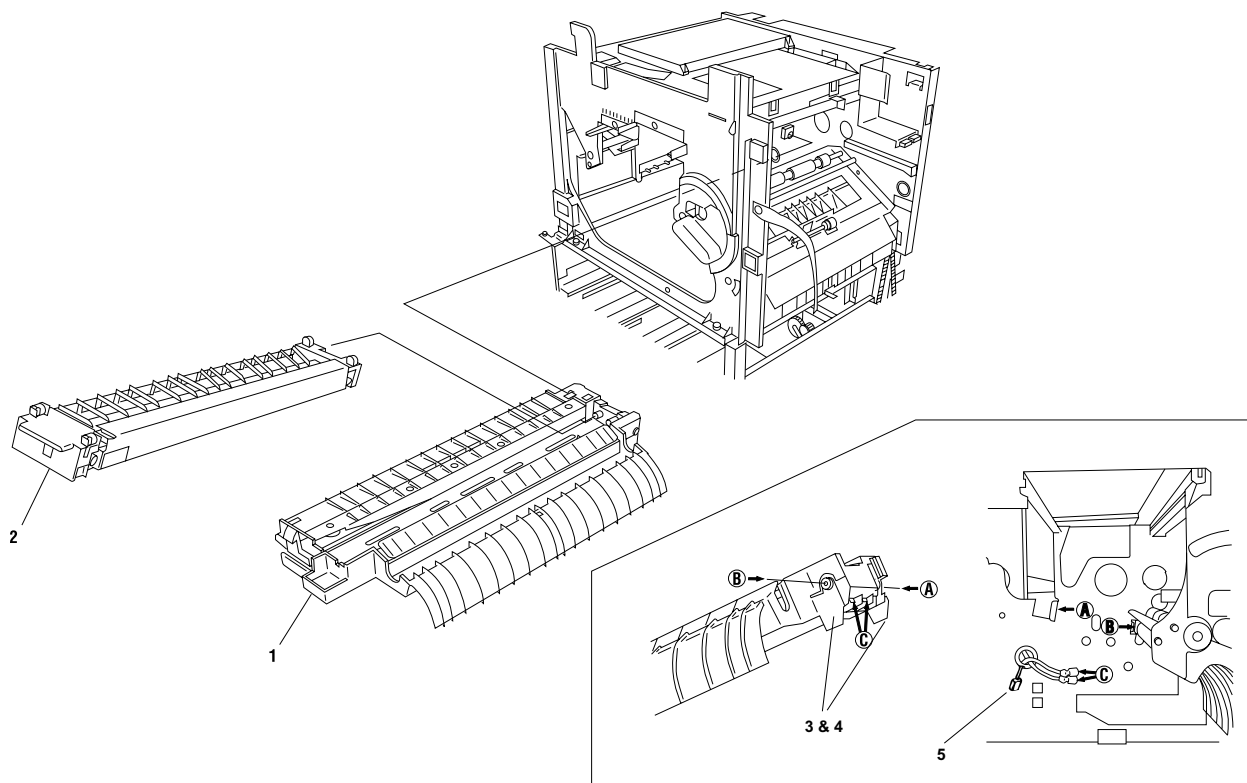

Figure 7-4. Transfer Guide Assembly Parts Locational Diagram

MINOLTA-QMS 4060 PARTS MANUAL

7-3.5. Paper Tray, Paper Lift Motor, and Tray Empty Sensor

Table 7-5. Paper Trays, Paper Size Sensors, Paper Lift Motor, and Tray Switch Sensor Parts Listing

Index No.	Composition and Quantity				Specification	Description	Remarks
1	3				857CA81212-E126	Custom tray	Not Shown
1	3					Tray assembly	
	1					Base assembly	
2		3				Metal fitting	
3		3				Screw	
4		3			857CA02626-E142	Switch	
5		6				Screw	
6		3			857CA02626-E157	Lift motor assembly	Includes 7-13
7			1			Metal fitting assembly	
8			1			Motor	
9			3			Screw	
10			1			Spring	
11			1			Gear	
12			1			C-ring	
13			1			Pulley	
14		9				Screw	
15	1				857CA02626-0179	Sensor Assembly	Paper size sensor board
16	1				857CA71001-3149	Wire Harness	Paper size not shown

MINOLTA-QMS 4060 PARTS MANUAL

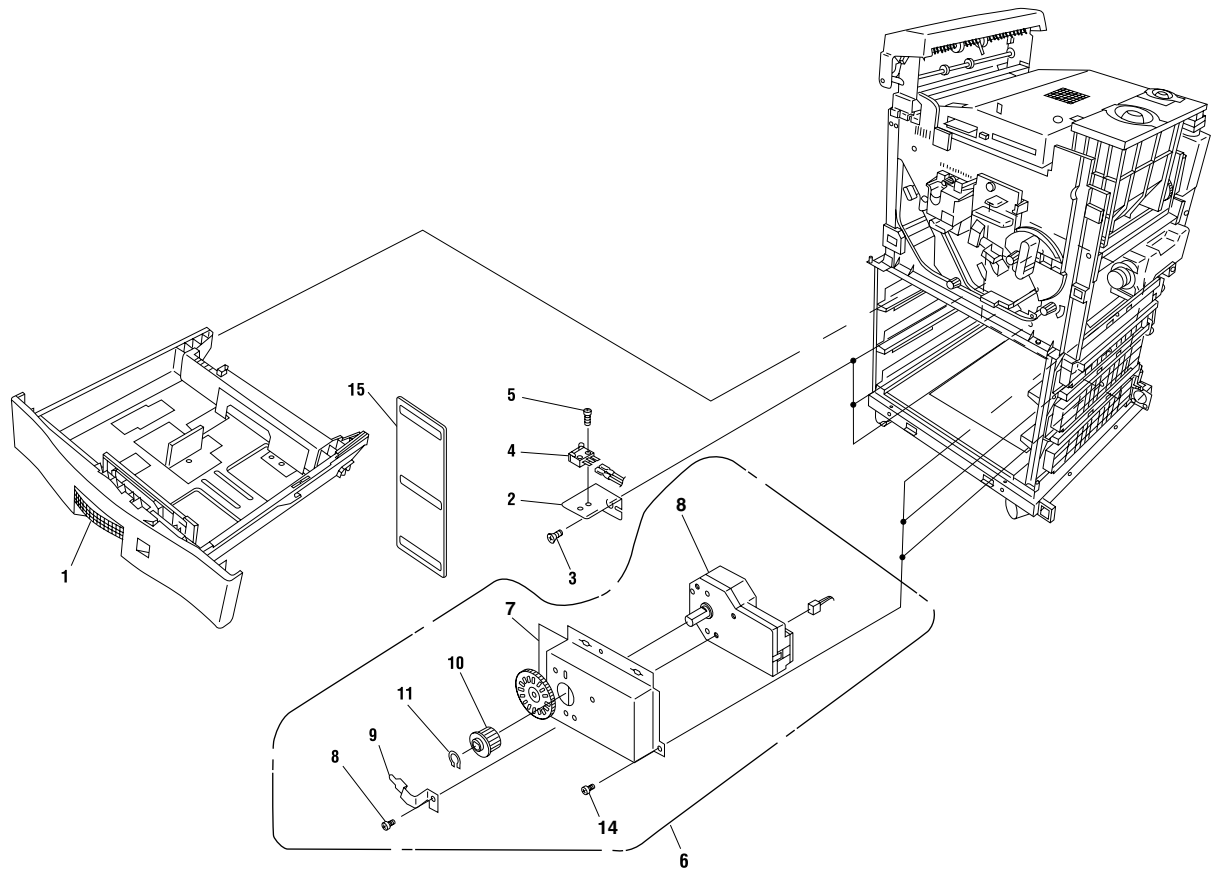

Figure 7-5. Paper Tray, Paper Lift Motor, and Tray Empty Sensor Parts Locational Diagram

MINOLTA-QMS 4060 PARTS MANUAL

7-3.6. Main Controller and Optical Unit

Table 7-6. Main Controller and Optical Units Parts Listing

Index No.	Composition and Quantity				Specification	Description	Remarks
	1					Printer unit	
1	1					Plate	
2	1					Plate	
3	8					Screw	
4		1			857CA71002-1840	Wire harness	Main Controller to Control Panel
5		1			857CA71002-1842	Wire harness	Main Controller to Optics
6		1			857CA71002-1841	Wire harness	Main Controller to Mechanism Contoller
7		1			857CA31214-C012	Fan	Fan 6
8		2				Screw	
9		1			857CA02625-D105	Optical unit	
10		1				Spring	
11		1				Collar	
12		1				Plate	
13		2				Screw	
14		1				Duct	Not Shown
15		2				Screw	Not Shown

MINOLTA-QMS 4060 PARTS MANUAL

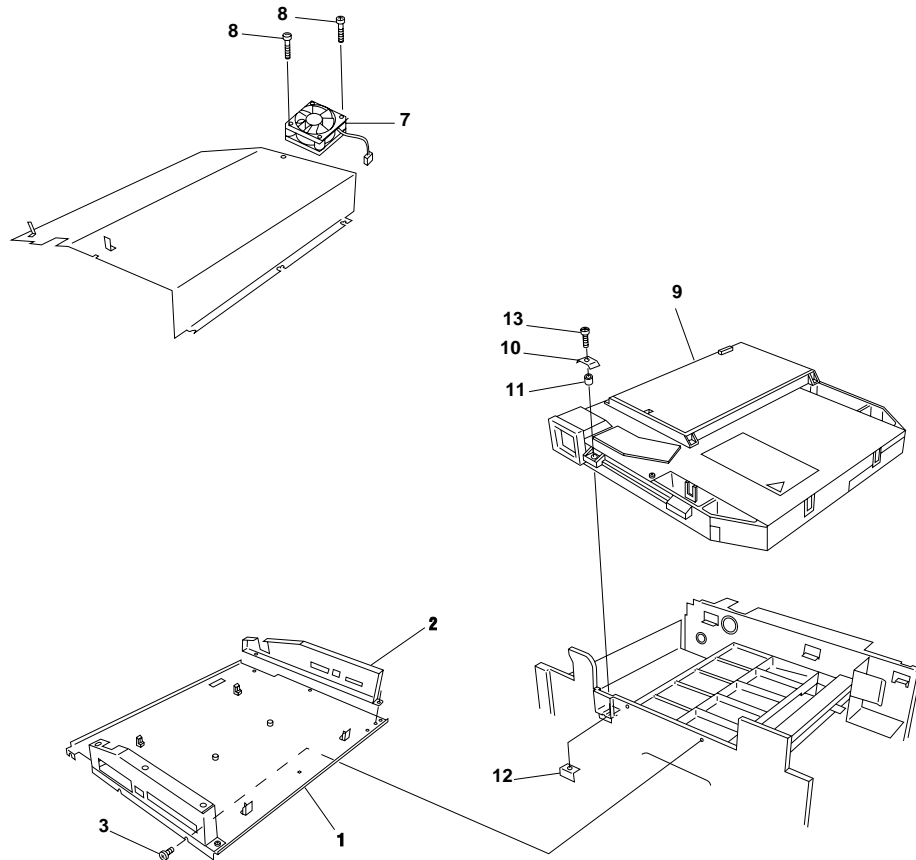

Figure 7-6. Main Controller and Optical Units Parts Locational Diagram

MINOLTA-QMS 4060 PARTS MANUAL

7-3.7. Ejection Unit and Operator Panel

Table 7-7. Ejection Unit and Operator Panel Parts Listing

Index No.	Composition and Quantity					Specification	Description	Remarks
1	1					857CA31214-0210	Cover assembly	
2		1					Cover, operator panel	
3		4					Screw	
4		1				857CA31214-0260	Door	Floppy cover
5	1					857CA31214-C004	Cover, operator bezel	
6		1					Metal fitting	
7		2					Screw	
8		1				857B8602410V424A	Switch	Standby switch
9	1					857CA31214-C026	Operator panel	
10	3						Screw	
11	1						Engine assembly	
12		1					Mechanism assembly	
13			1			857CA02626-F900	Ejection unit	
14				1			Ejection cover asy	
15				1			Metal fitting	
16				2			Screw	
17				1		857CA02951-5075	Sensor	Stack full sensor
18					1		Sensor	PS7
19					1	857CA02951-5074	Sensor	
20					1	857CA02626-0922	Discharge brush	
21			1			857CA02626-E908	Roller assembly	
22				1			Pulley	
23				2			E-ring	
24					1	857CA02626-E907	Roller assembly	
25				1			Pulley	
26				2			E-Ring	
27					1	857CA98001-6941	Belt	
28					1	857CA02626-E142	Switch	
29					1		Screw	
30		2					Screw	

MINOLTA-QMS 4060 PARTS MANUAL

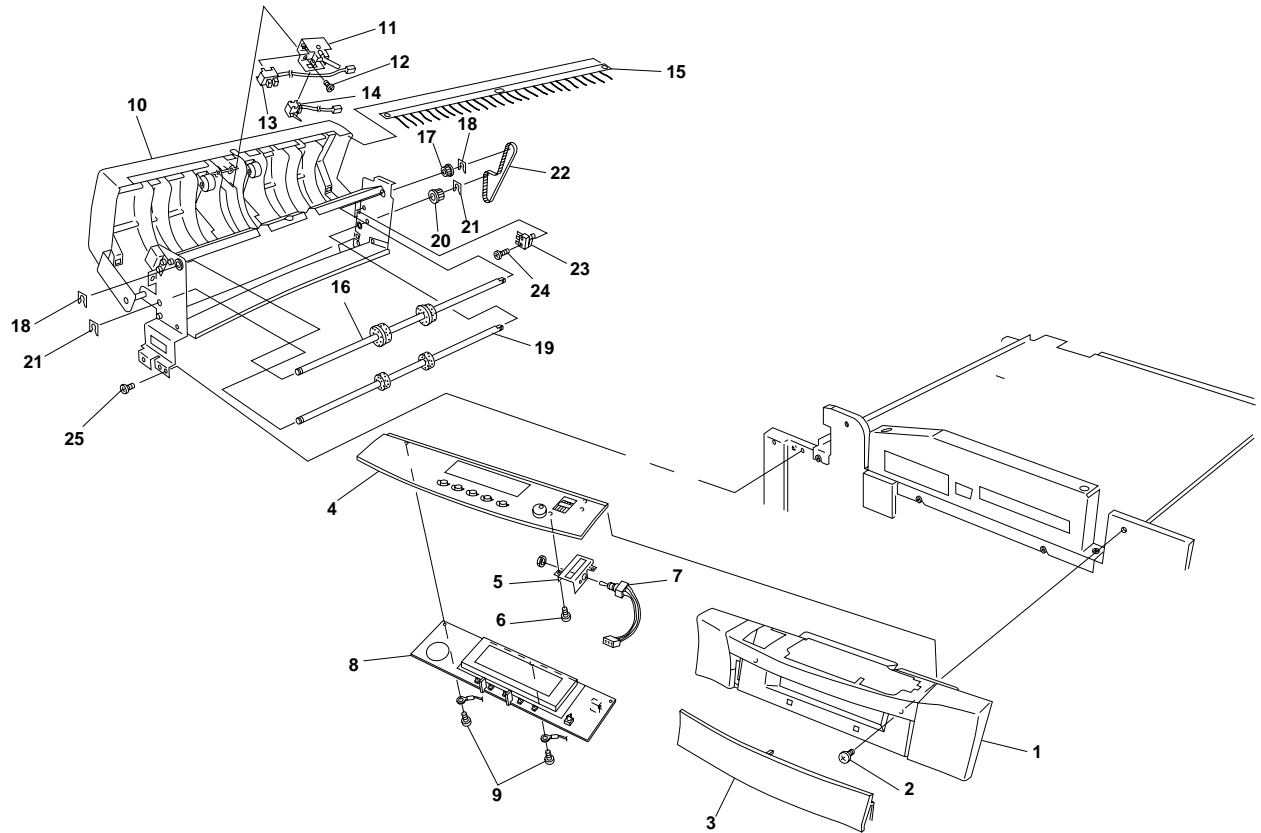

Figure 7-7. Ejection Unit and Operator Panel Parts Locational Diagram

MINOLTA-QMS 4060 PARTS MANUAL

7-3.8. Reversing Unit

Table 7-8. Reversing Unit Parts Listing

Index No.	Composition and Quantity				Specification	Description	Remarks
1	1				857CA02626-F800	Mechanism assembly	
2		1			857CA02626-E808	Reversing unit	
3			2			Roller	
4			1			Bushing	
5			2			Pulley	
6		1			857CA98001-6940	E-ring	
7		1			857CA02626-E846	Belt	
8			1			Motor assembly	
9		3				Pulley	
10		3				Bushing	
11		1			857CA02951-5071	Screw	
12		2				Solenoid	
13		1				Screw	
14		1				Plate	
15		1			857CA55003-1612	Screw	
16		1				Sensor	PS6
		1				Screw	
17		1			857CA02626-E820	Stacker select unit	
18		2				Solenoid	
						Screw	

MINOLTA-QMS 4060 PARTS MANUAL

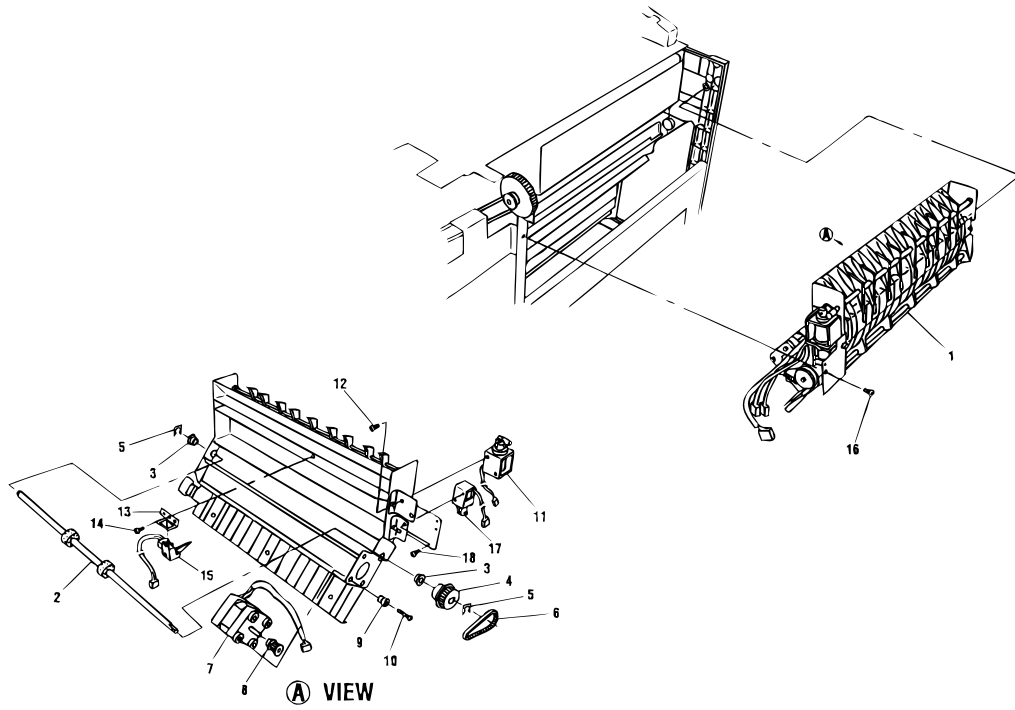

Figure 7-8. Reversing Unit Parts Locational Diagram

MINOLTA-QMS 4060 PARTS MANUAL

7-3.9. Paper Path Transport Assembly

Table 7-9. Paper Path Transport Assembly Parts Listing

Index No.	Composition and Quantity				Specification	Description	Remarks
1	1					Transport assembly	
2	1				857CA02626-E401	Transport cover Assy	
3		1				Metal fitting (L) Assy	
4		1				Screw	
5		2				Spacer	
6		1				Metal fitting (R) Assy	
7		1				Screw	
8		1			857CA02626-E142	Switch	
9		1				Screw	
10		2			857CA04192-F011	Receiving Plate Assy	Not Shown
11		4				Screw	Not Shown
12		3			857CA02626-E406	Roller	
13		3				Screw	
14		1			857CA02626-0416	Strap	
15		2				Screw	
16			1		857CA02626-E441	Motor assembly	
17			1			Pulley M	
18			2			Screw	
19		3				Screw	
20		3				Nut	
21	1				857CA98001-6943	Belt	

MINOLTA-QMS 4060 PARTS MANUAL

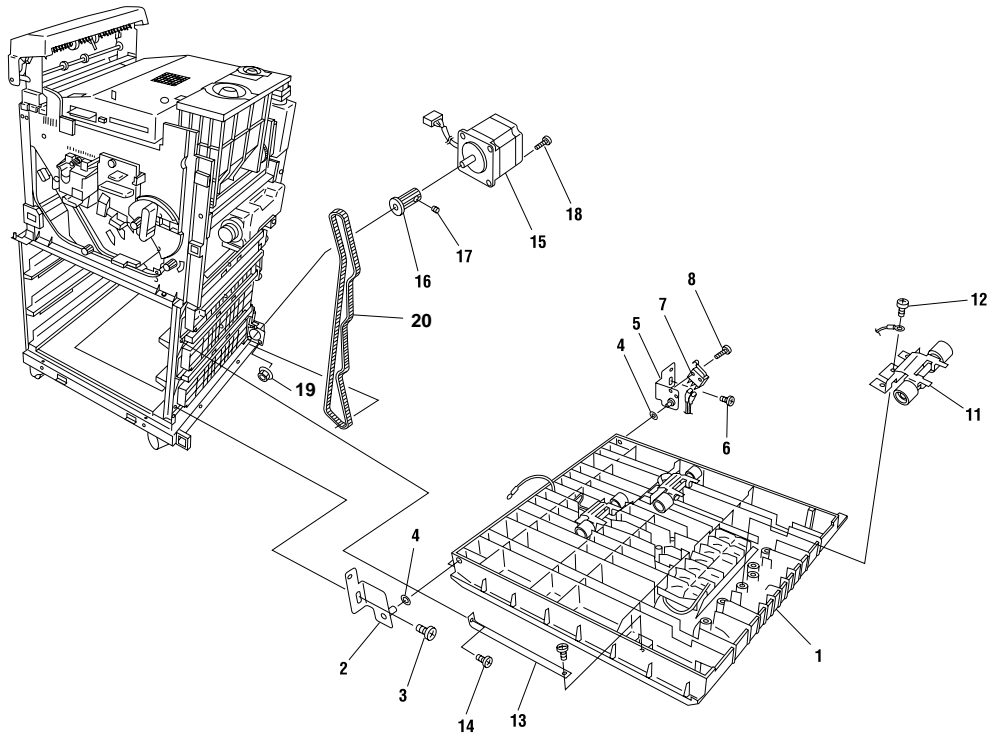

Figure 7-9. Paper Path Transport Assembly Parts Locational Diagram

MINOLTA-QMS 4060 PARTS MANUAL

7-3.10. Paper Feed Unit

Table 7-10. Paper Feed Unit Parts Listing

Index No.	Composition and Quantity				Specification	Description	Remarks
1	1	2			857CA02626-E330	Paper feed unit Paper feed unit	Upper/middle: E330
1		1			857CA02626-E331	Paper feed unit	Lower:E331
2			1			Guide U	
3			2			Screw	
4			1		857CA55300-1610	Sensor	PS1: Paper empty sensor
5		1			857CA55300-1625	Sensor	
6		1			857CA02626-E312	Roller assembly	
7				1		Plate H assembly	
8				1		Screw	
9				1		Pulley H	
10				2		E-ring	
11			1			Pick plate	
12			1			Shaft P	
13			4			Ring	
14			2		857CA02626-E325	Roller	
15			2			Roller	
16			1		857CA02626-E324	Roller	
17			1			Roller	
18			2		857CA02626-0337	Clutch	
19			1		857CA98001-6949	Torque limiter	
20			1			Pulley P	
21			1			Pulley F	
22			1		857CA98001-6944	Belt	
23			1			Plate	
24			1		857CA55003-1620	Motor	
25		6				Screw	
26		1				Plate	
27			1		857CA55003-1615	Sensor	Paper Level Sensor

MINOLTA-QMS 4060 PARTS MANUAL

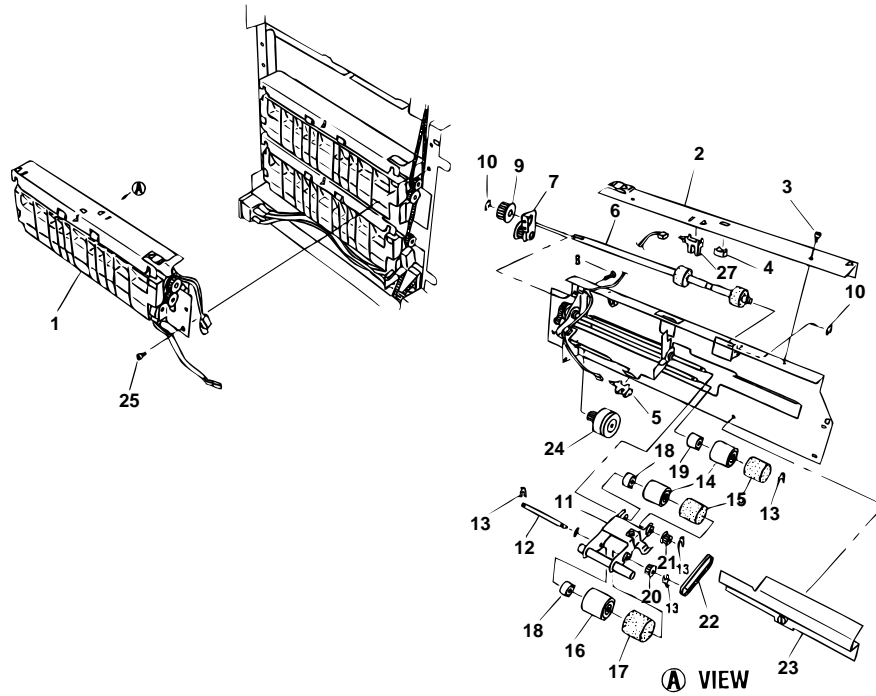

Figure 7-10. Paper Feed Unit Parts Locational Diagram

MINOLTA-QMS 4060 PARTS MANUAL

7-3.11. Toner Hopper and Developer Units

Table 7-11. Toner Hopper and Developer Units Parts Listing

Index No.	Composition and Quantity				Specification	Description	Remarks
1	1					Mechanism assembly	
2	1				857CA02626-E240	Toner hopper	
3		1			857CA02626-E252	Motor assembly	
4			1			Rack	
5			1			Motor	
6			2			Screw	
7			1			Screw	
8			1			Gear	
9			1			C-ring	
10		3				Screw	
11	4					Screw	
12	1				857CA02626-E200	Developer unit	
					857CA02626-1130	Developer Rail	

MINOLTA-QMS 4060 PARTS MANUAL

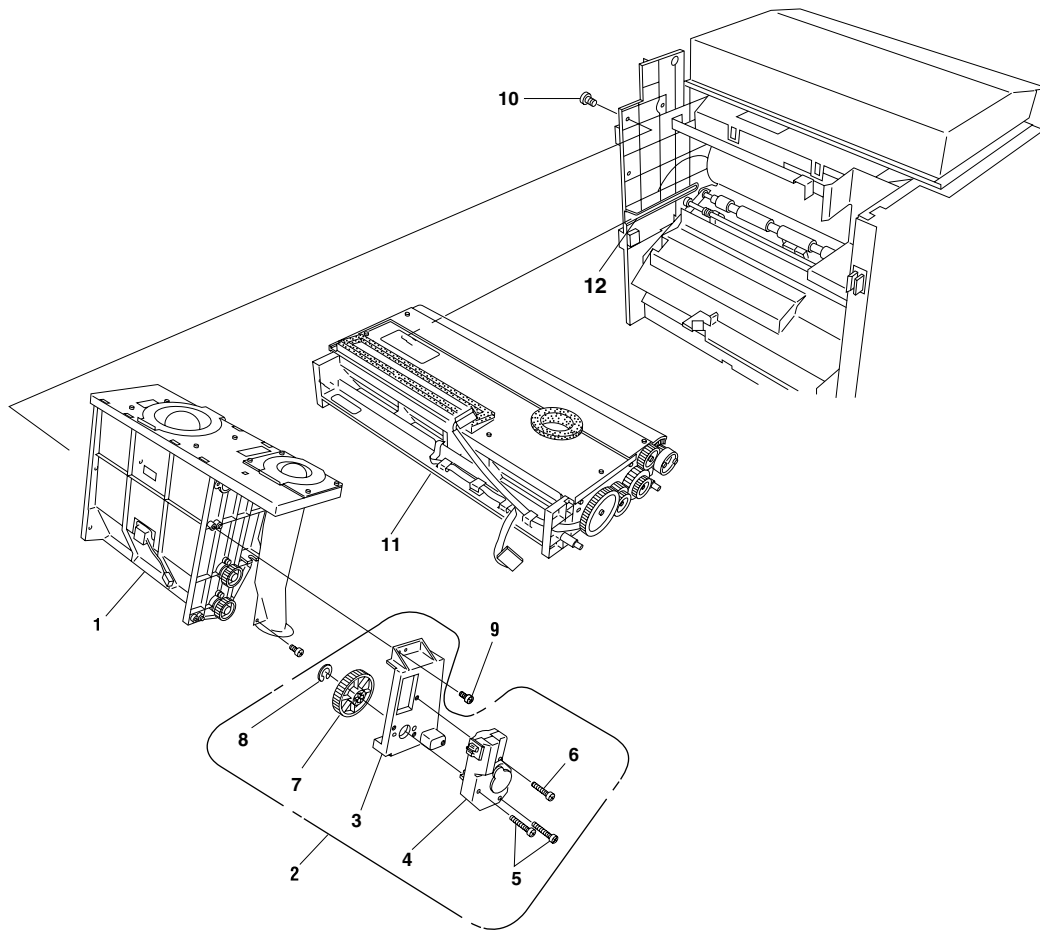

Figure 7-11. Toner Hopper and Developer Units Parts Locational Diagram

MINOLTA-QMS 4060 PARTS MANUAL

7-3.12. Main Frame Assembly

Table 7-12. Main Frame Assembly Parts Listing

Index No.	Composition and Quantity				Specification	Description	Remarks
	1					Main frame assembly	
1	1				857CA02626-E122	Guide assembly	
2		1				Roller	Not Shown
3		2				Bearing	Not Shown
4		1				Gear	Not Shown
5		2				E-Ring	Not Shown
6		1				Knob	Not Shown
7		1				Screw	
8		1			857B86L24100822A	Sensor	PS4
9	2					Screw	
10	1				857CA98001-6946	Switch	
11	1				857CA02626-E110	LED Cover	Not Shown
12	2					Screw	Not Shown
13	1				857CA02626-E125	LED Erase Unit	
14	1					Screw	
15	1				857CA98001-6946	Switch	
16	1					Plate	Not Shown
17	3					Screw	Not Shown
18	1					Plate	Not Shown
19	1					Screw	Not Shown
20	1				857CA02626-E147	Registration roller assy	
21	1					Bearing 8	
22	1					Knob	
23	1					Screw	
24	1					Spacer	
25	1					E-ring	
26	1				857B86L24100880A	Clutch	
27	1				857CA02626-E133	Roller assembly	
28	2					Bearing	
29	1					Knob	
30	1					Screw	
31	1					Pulley H	
32	1					E-Ring	
33	2				857CA055003-1627	Sensor	PS2, PS3
34	1					Cover Assy	
35	1				857CA02626-E142	Switch	
36	1					Screw	
37	2					Screw	
38	1					Plate	
39	1					Plate Spring	
40	1					Screw	
41	1					Shaft	
42	1				857CA02626-E100	Backup Roller	

MINOLTA-QMS 4060 PARTS MANUAL

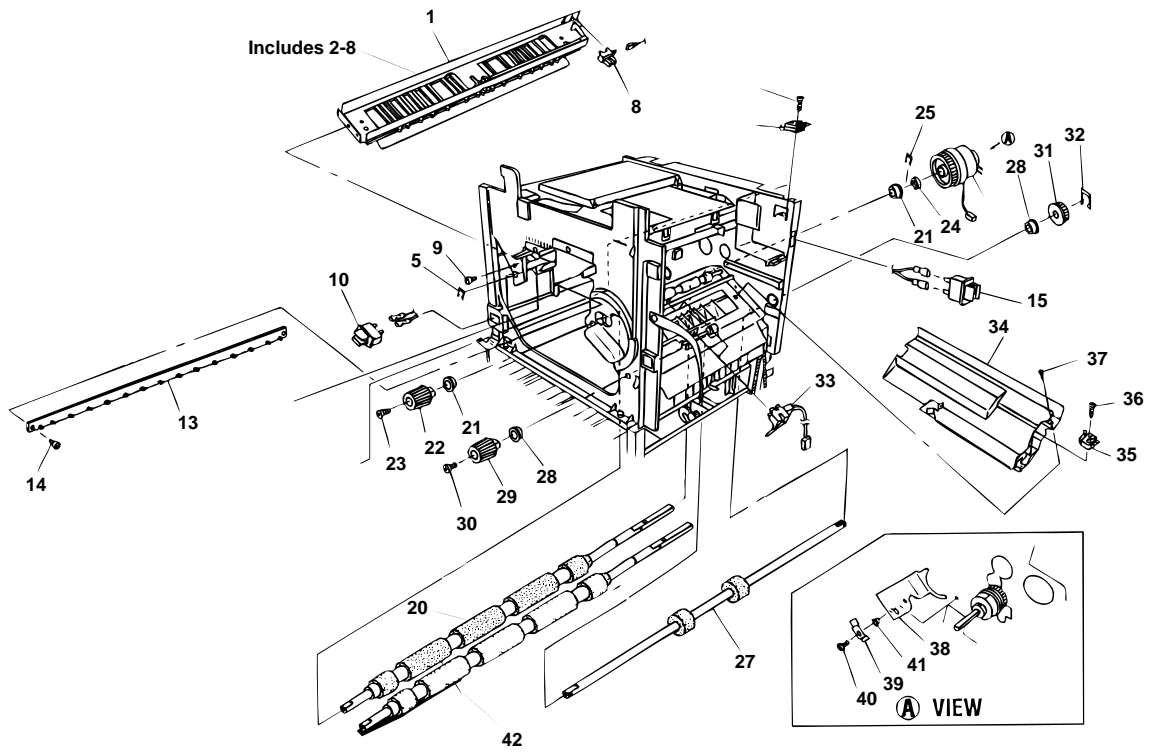

Figure 7-12. Main Frame Assembly Parts Locational Diagram

MINOLTA-QMS 4060 PARTS MANUAL

7-3.13. Drive Unit M

Table 7-13. Drive Unit M Parts Listing

Index No.	Composition and Quantity					Specification	Description	Remarks
	1						Mechanism assembly	
1	1					857CA02626-E732	Driving M sub asy	
2		1				857CA02626-E715	Fan	Fan 2
3		1				857CA02626-E716	Fan	Fan 4
4		1				857CA02951-5078	Switch	
5		1					Screw	
6		1				857CA02626-E718	Fan	Fan 7
7		1					Finger guard	
8		2					Screw	
9		1					Motor	
10		4					Screw	
		1					Waste toner unit	
11			1				Plate	
12			1			857B86L24100822A	Sensor	Waste toner sensor
13		1					Screw	
14		1					Spring	
15		1				857CA98001-6947	Switch	
16		1					Bracket	
17		5					Screw	
18		1					Belt	
19		1					Belt	
20		1					Belt	
21		4					Screw	
22		8					Belt	
23		1				857CA02626-E734	Waste Toner unit	
24		1					Fan Plate	
25		1					Screw	

MINOLTA-QMS 4060 PARTS MANUAL

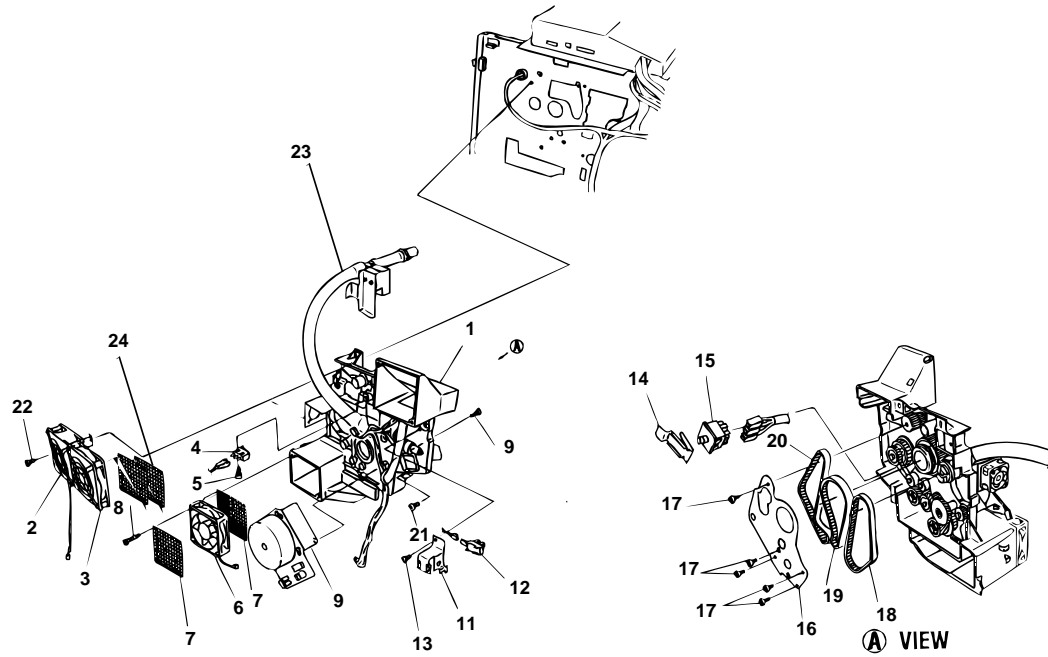

Figure 7-13. Drive Unit M Parts Locational Diagram

MINOLTA-QMS 4060 PARTS MANUAL

7-3.14. Mechanism Controller PCB, HVPS, LVPS, and LVPS Fan

Table 7-14. Mechanism Controller PCB, HVPS, LVPS, and LVPS Fan Parts Listing

Index No.	Composition and Quantity				Specification	Description	Remarks
	1					Engine assembly	
		1				PCB assembly	
1			1			Metal fitting	
2				1	857CA02626-J002	PCB	Mechanism controller
3		2				Screw	
			1			Cable	
4				1	857CA71001-2654	Wire harness	
5				1	857CA71001-2655	Wire harness	
6				1	857CA71002-1841	Wire harness	
7				3	857CA02626-E322	Wire harness	
8				1	857CA02626-E320	Wire harness	
9				1	857CA02626-E850	Wire harness	
10				1	857CA02951-8351	HV power supply	
11				4		Screw	
12				1	857CA02951-3631	Power supply unit	
13				6		Screw	
14				1	857CA02626-E159	Fan	Fan 5
15				1		Finger guard	
16				2		Screw	
17				2	857CA98001-6948	Relay	
18				2		Screw	
19				1	857CA71001-2859	Cable	Not Shown
20				1	857CA71001-2685	Cable	Not Shown
21				1		Metal Fitting	
22				2		Screw	

MINOLTA-QMS 4060 PARTS MANUAL

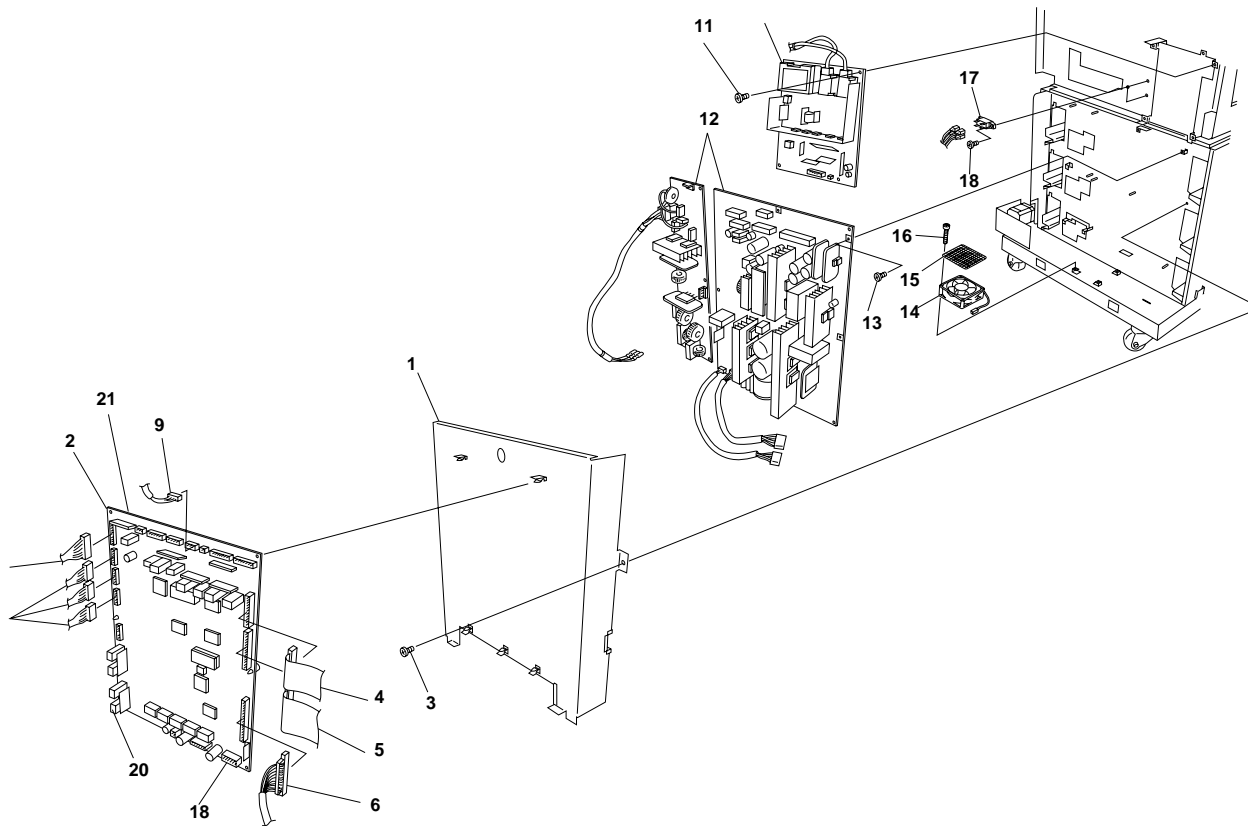

Figure 7-14. Mechanism Controller PCB, HVPS, LVPS, and LVPS Fan Parts Locational Diagram

MINOLTA-QMS 4060 PARTS MANUAL

7-3.15. Drive Unit D Motor, Drive Unit E, and Drive Unit E Belt

Table 7-15. Drive Unit D Motor, Drive Unit E, and Drive Unit E Belt Parts Listing

Index No.	Composition and Quantity				Specification	Description	Remarks
	1					Mechanism assembly	
1	1				857CA02626-E660	Driving unit E	
2		1			857CA98001-6942	Belt	
3		4				Screw	
4		1			857CA02626-F600	Driving unit D	
5			1		857CA02626-E602	Motor	
6			2			Screw	
7			1		857CA02626-E142	Switch	
8			1			Screw	
9		2				Screw	

MINOLTA-QMS 4060 PARTS MANUAL

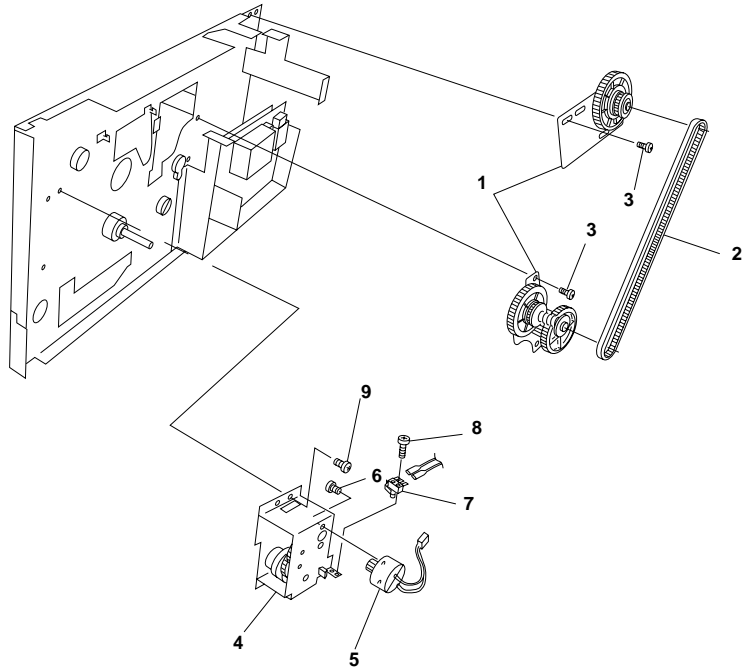

Figure 7-15. Drive Unit D Motor, Drive Unit E, and Drive Unit E Belt Parts Locational Diagram

MINOLTA-QMS 4060 PARTS MANUAL

7-4. LCIF Parts Locational Diagrams and Listings

7-4.1. LCIF Frame

Table 7-16. LCIF Frame Parts Listing

Index No.	Composition and Quantity				Specification	Description	Remarks
*1	1					Label lock release	
2	1				857CA81101-1049	Top cover	
3		10				Screw	
4	2				857CA81101-1050	Side cover	
5	1				857CA81101-1043	Hinge, Lower	
6		2				Screw	
7	1				857CA81003-5657	PCA-B	(PCA-B)
8		1				Screw	
9	1				857CA81101-1013	Lock release lever	
10	1					Button	
11	1				857CA81003-5651	Door	
12		1				Screw	
13	1				857CA81101-1042	Hinge, Upper	
14	2					Screw	
15	1					Support Stand	
16	1					Support Stand Guide	
17	2				857CA81003-5602	Adjusting bolt	
18	2				857CA81003-5601	Rail	

MINOLTA-QMS 4060 PARTS MANUAL

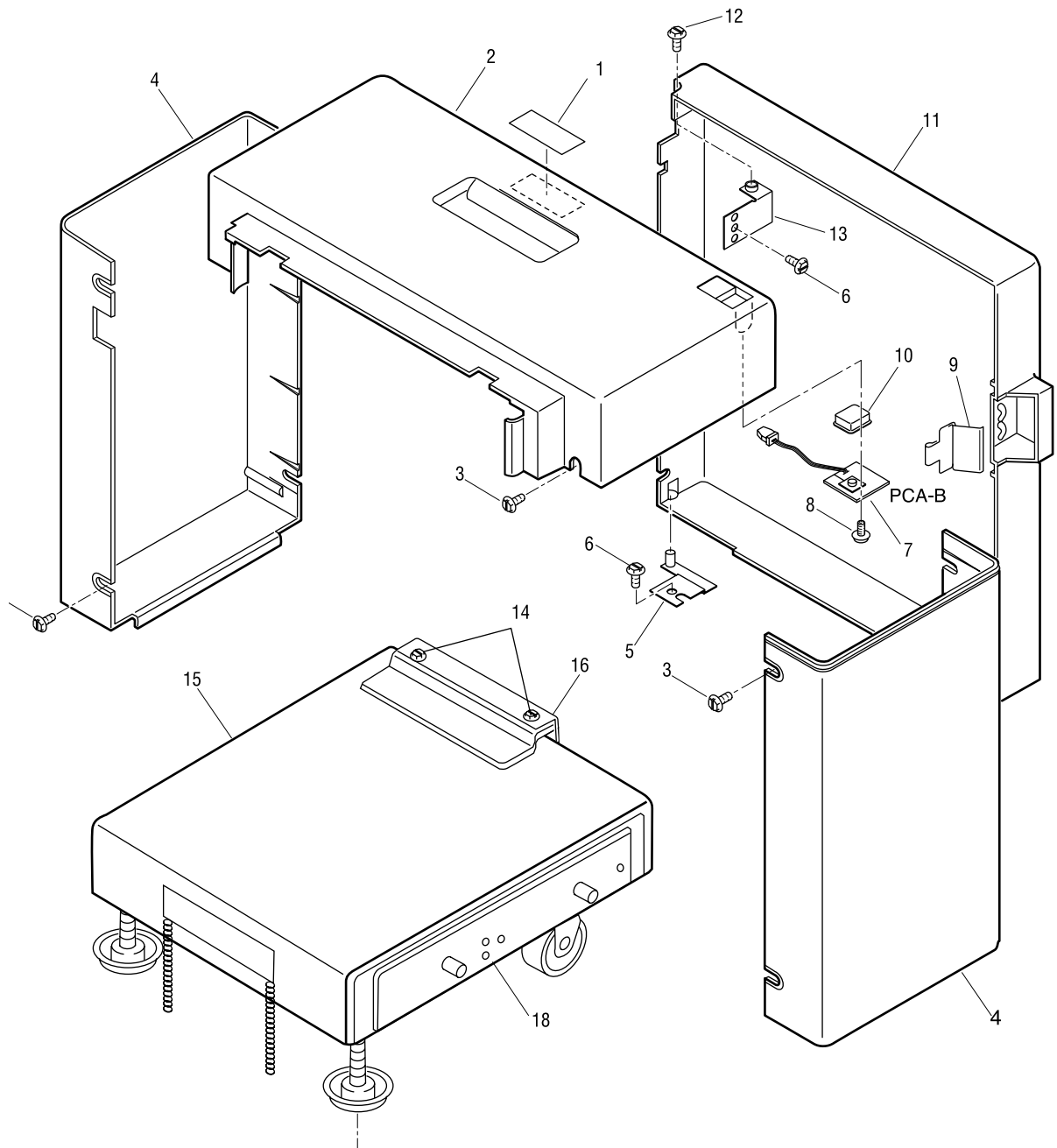

Figure 7-16. LCIF Frame Parts Locational Diagram

MINOLTA-QMS 4060 PARTS MANUAL

7-4.2. Paper Feed Assembly

Table 7-17. LCIF Paper Feed Assembly Parts Listing

Index No.	Composition and Quantity			Specification	Description	Remarks
1	1			857CA81101-1033	Bracket, rear	
2	2			857CA81101-1117	Screw	
3	3			857CA81101-1107	Washer	
4	1			857CA81101-1051	Frame, rear	
5	12			857CA81101-1112	Screw	
6	1			857CA81101-1084	Harness	
7	1			857CA81101-1113	Screw	
8	1			857CA81101-1053	Guide frame	
9	2			857CA81003-5664	Tension spring	Not Shown
10	1			857CA81101-1035	Size plate	
11	1			857CA81101-1040	Ground plate	
12	1			857CA81101-1054	Frame, lower	
13	1			857CA81101-1032	Bracket, front	
14	2			857CA81003-5653	Photo interrupter	
15	1			857CA81101-1016	Bracket	
16	1			857CA81003-5656	PCA-A (with IC)	(PCA-A)
17	1			857CA81101-1047	Bracket	
18	1			857CA81101-1052	Frame, front	
19	1			857CA81101-1056	Actuator	
20	1			857CA81003-5654	Motor	
21	1			857CA81101-1047	Bracket	
22	1			857CA81101-1079	Gear, 52T	
23	4			857CA81101-1023	PWB support, 6.35H	
24	1			857CA81003-5663	Separator roller asy	One of the components
25	1			857CA81101-1001	Stopper Ring	
26				857CA81101-1087	Label	

MINOLTA-QMS 4060 PARTS MANUAL

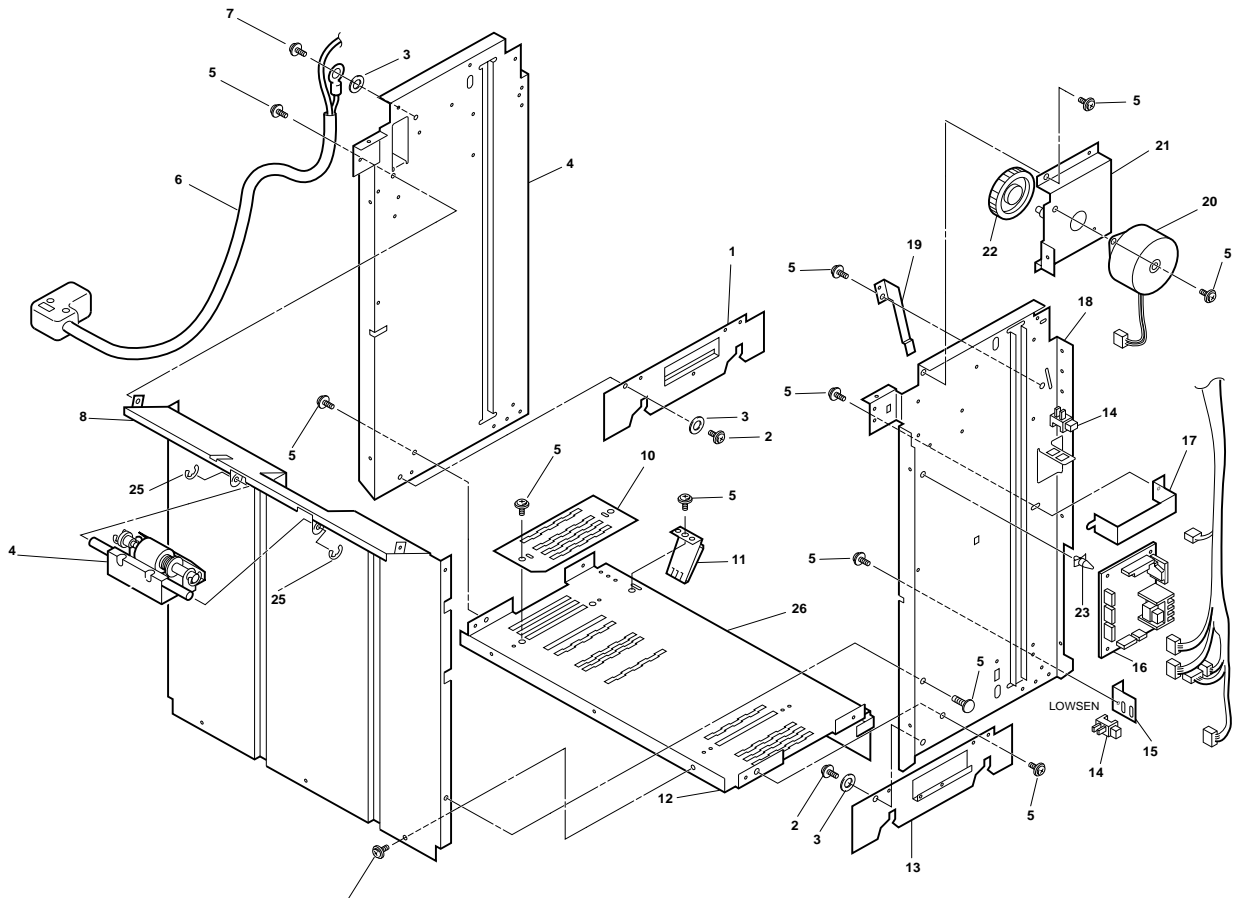

Figure 7-17. LCIF Paper Feed Assembly Parts Locational Diagram

MINOLTA-QMS 4060 PARTS MANUAL

7-4.3. LCIF Paper Transport

Table 7-18. LCIF Paper Transport Assembly Parts Listing (Sheet 1 of 2)

Index No.	Composition and Quantity				Specification	Description	Remarks
1	1				857CA81101-1090	Lever	
2	1				857CA81101-1065	Actuator	
3	1				857CA81101-1034	Size plate	
4	2				857CA81101-1116	Screw	
5	2				857CA81101-1007	Bushing	
6	4				857CA81101-1010	Sprocket, 13T	
7	1				857CA81101-1019	Gear, 30T	
8	8				857CA81101-1109	E-Ring	
9	2				857CA81101-1060	Chain, 136LNK	
10	2				857CA81101-1045	Mounting plate	
11	3				857CA81101-1117	Screw	
12	4				857CA81101-1021	Guide roller	
13	1				857CA81101-1020	Gear, 18/50T	
14	1				857CA81101-1019	Gear, 28/56T	
15	1				857CA81101-1106	Worm gear	
16	1				857CA81101-1068	Set Screw	
17	1				857CA81101-1070	Bracket	
18	1				857CA81101-1102	Bracket	
19	8				857CA81101-1045	Screw	
20	1					Bracket	
21	1				857CA81003-5655	Motor	Hmot
22	1				857CA81101-1011	Washer	
23	1				857CA81101-1014	Ground plate	
24	1				857CA81101-1114	Screw	
25	1				857CA81101-1072	Regulating plate, front	
26	2				857CA81101-1061	Plate nut	
27	2				857CA81101-1104	Screw	
28	1				857CA81101-1073	Friction sheet	
29	1				857CA81101-1041	Paper plate	
30	1				857CA81101-1017	Actuator	
31	1				857CA81101-1015	Shaft	
32	1				857CA81101-1012	Shoulder screw	
33	1				857CA81101-1044	Bracket	
34	2				857CA81101-1057	Tension spring	
35	2				857CA81101-1024	Rubber cushion	
36	1				857CA81101-1059	Wire	
37	2				857CA81003-5652	Lock lever	
38	4				857CA81003-5653	Photo interrupter	Setsen, Empsen Ksen, Levsen
39	2				857CA81101-1004	Collar	
40	1				857CA81101-1058	Pressure spring	

MINOLTA-QMS 4060 PARTS MANUAL

Table 7-18. LCIF Paper Transport Assembly Parts Listing (Sheet 2 of 2)

Index No.	Composition and Quantity	Specification	Description	Remarks
41	1	857CA81101-1066	Actuator	
42	2	857CA81101-1008	Pin	
43	1	857CA81101-1055	Frame, top	
44	1	857CA81101-1080	Gear, 30T	
45	5	857CA81101-1005	Bushing	
46	1	857CA81101-1103	Screw	
47	7	857CA81101-1082	Shaft	
48	1	857CA81101-1121	Pin	
49	1	857CA81101-1064	Actuator	
50	1	857CA81101-1026	Tension spring	
51	1	857CA81101-1003	Label, max	
52	1	857CA81101-1071	Regulating plate, rear	
53	4	857CA81101-1009	Cable tie	
54	1	857CA81101-1022	Edge cover	
55	2	857CA81101-1083	Wiring saddle	
56	1	857CA81003-5662	Pick roller asy	One of the Components of C56368
57	1	857CA81101-1108	Retaining Ring	
58	1	857CA81101-1101	Screw	

MINOLTA-QMS 4060 PARTS MANUAL

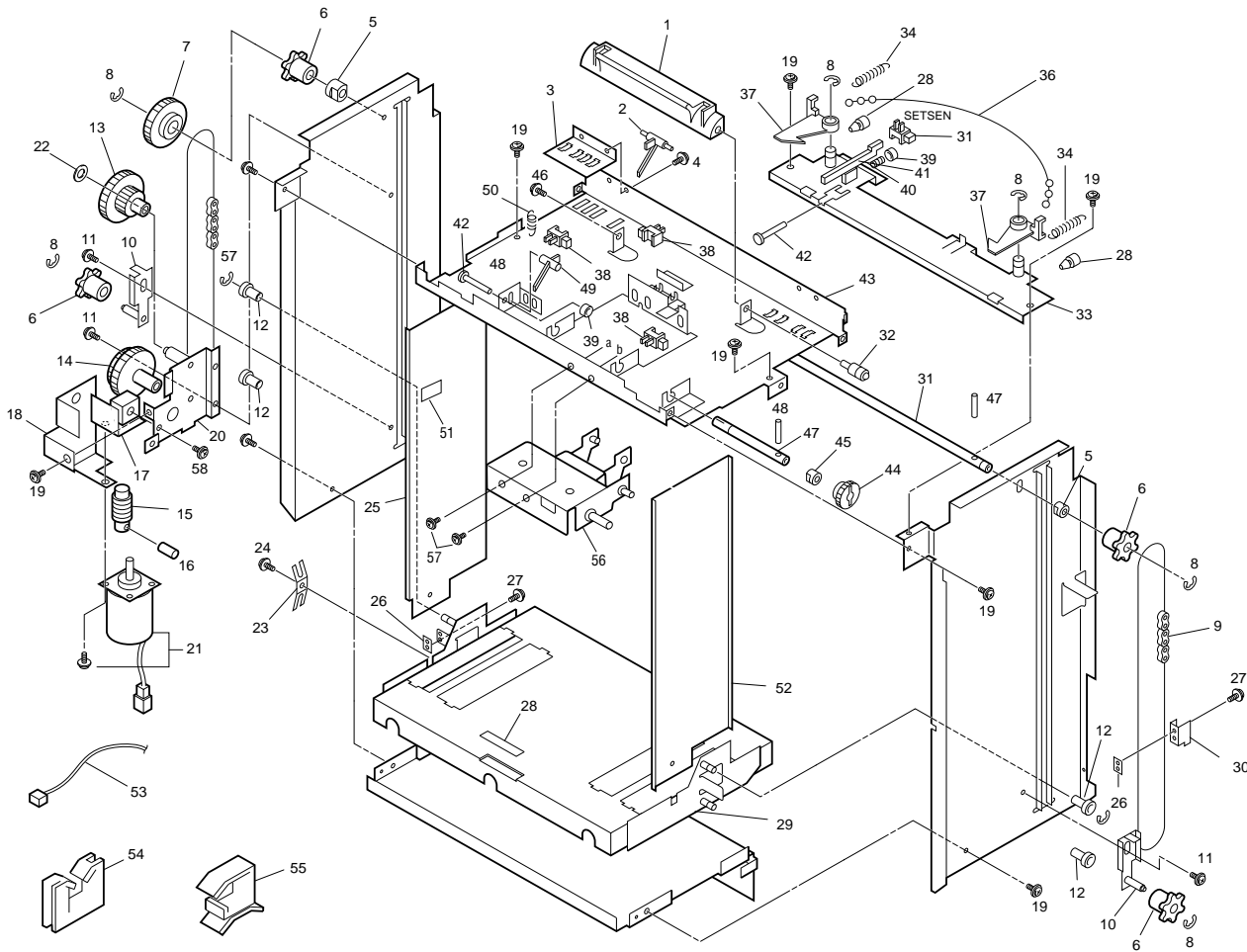

1123

Figure 7-18. LCIF Paper Transport Assembly Parts Locational Diagram

MINOLTA-QMS 4060 PARTS MANUAL

MINOLTA-QMS 4060 PARTS MANUAL

7-5. LCOS Parts Locational Diagrams and Listings

7-5.1. LCOS Attachment Parts

Table 7-19. LCOS Attachment Parts Listing

Index No.	Quantity	Specification	Description	Remarks
1	1	857CA02542-0189	Interface Cable	
2	1	857CA02542-0202	Knob	
	1	857CA02542-0193	Screw	
				Not shown Miscellaneous screws for LCOS

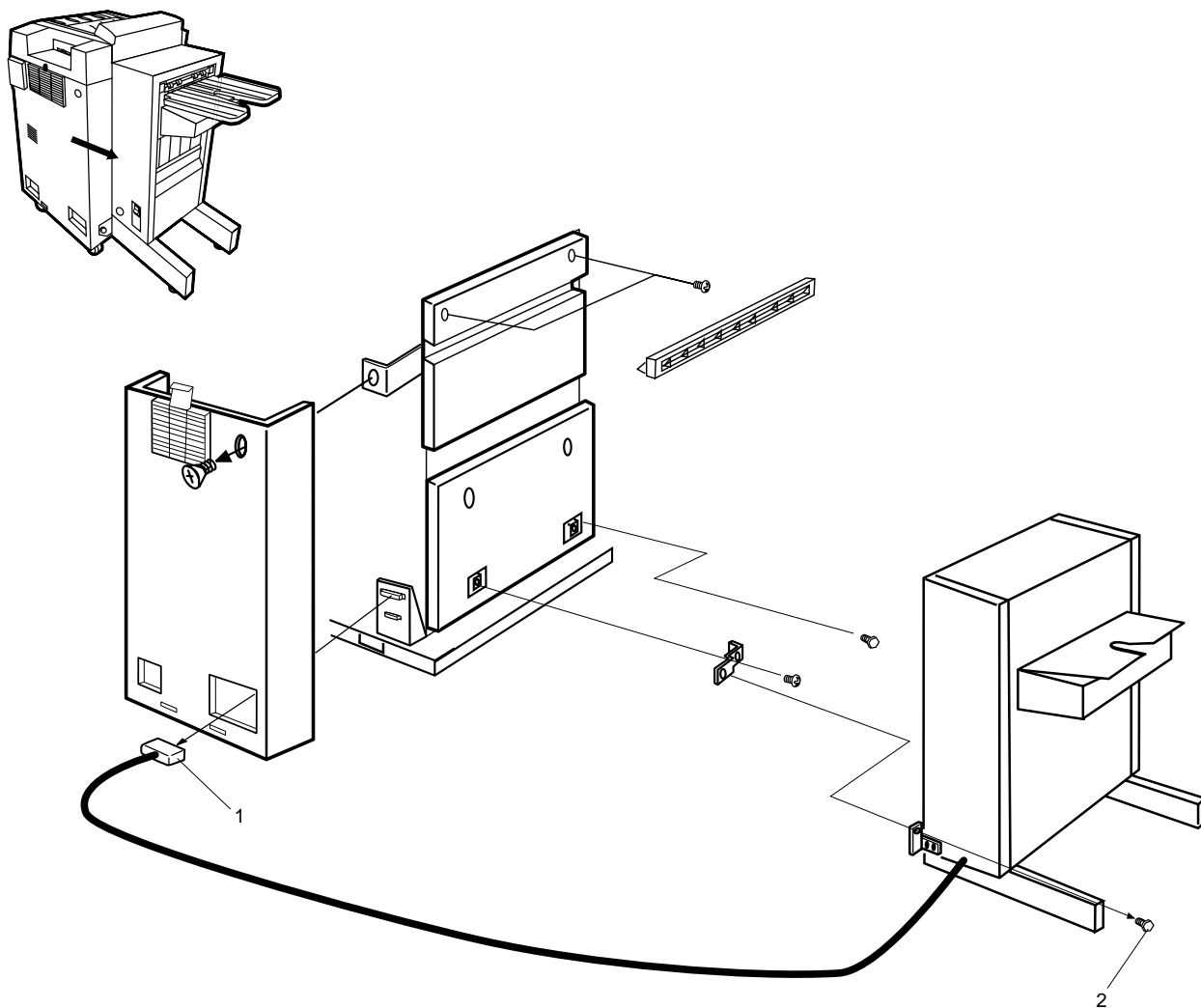

Figure 7-19. LCOS Attachment Parts Locational Diagram

MINOLTA-QMS 4060 PARTS MANUAL

7-5.2. LCOS Stacker Frame

Table 7-20. LCOS Stacker Frame Assembly Parts Listing

Index No.	Quantity	Description	Specification	Remarks
1	1	Front Door	857CA02542-0199	Diagnostic SEN8
2	1	LED Unit	857CA02542-0165	
3	1	Offset Motor Assy	857CA02542-0180	
4	1	Micro Switch	857CA02542-0130	
5	1	Brush	857CA02542-0154	
6	1	Top Cover	857CA02542-0183	
7	1	Tray	857CA02542-0186	
8	1	Left Side Cover	857CA02542-0188	
9	1	LED Unit Cable	857CA02542-0190	
10	4	Caster	857CA02542-0191	
11	2	Hinge	857CA02542-0192	

MINOLTA-QMS 4060 PARTS MANUAL

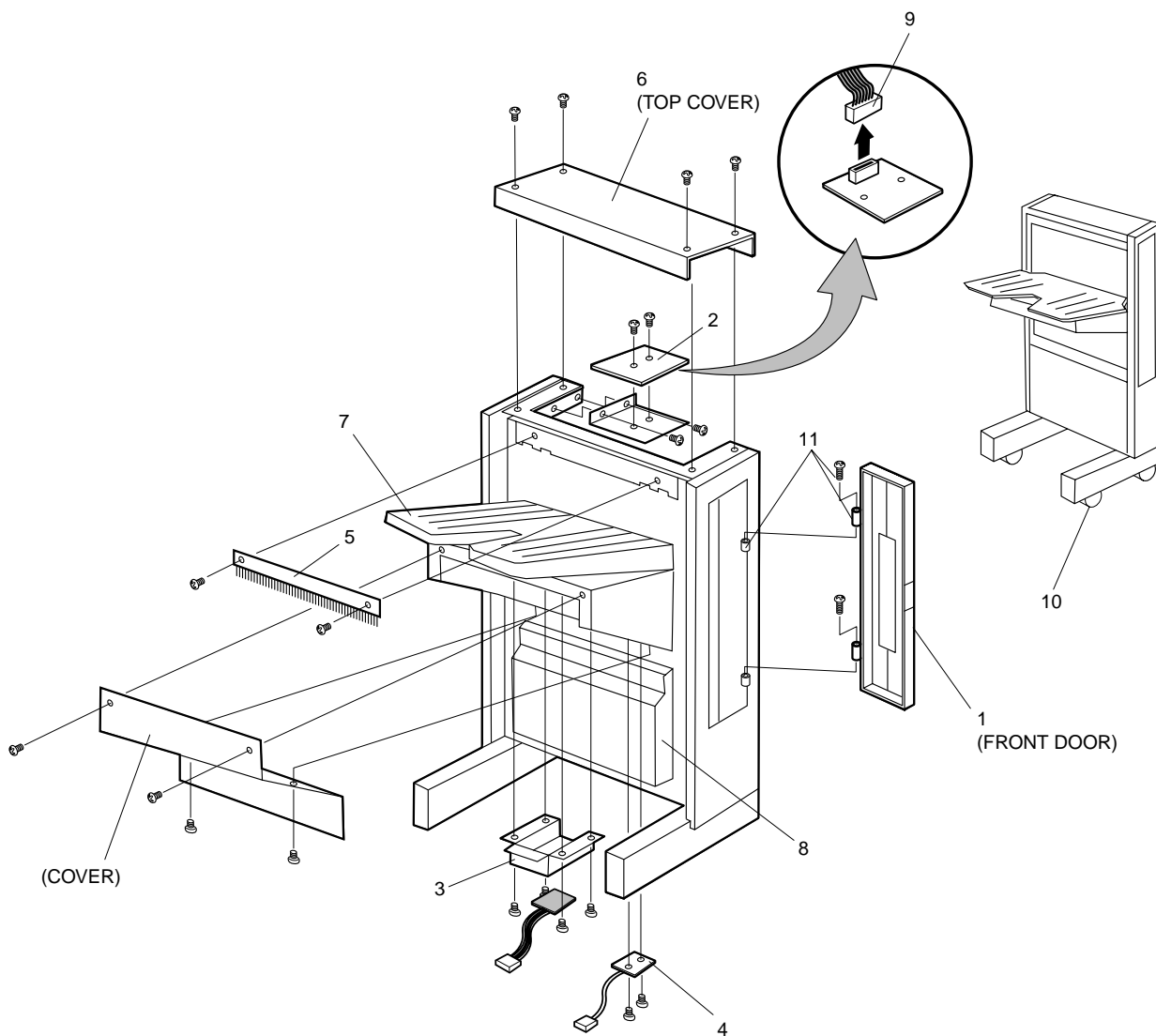

Figure 7-20. LCOS Stacker Frame Assembly Parts Locational Diagram

MINOLTA-QMS 4060 PARTS MANUAL

7-5.3. LCOS Controls and Cover Assemblies

Table 7-21. LCOS Controls and Covers Assemblies Parts Listing

Index No.	Quantity	Description	Specification	Remarks
1	1	Guide Sensor	857CA02542-0122	Switchback Detector Sensor (SEN4)
2	1	Guide Solenoid	857CA02542-0150	Switchback Detector Solenoid
3	1	Locker Unit	857CA02542-0182	100V
4	1	Locker Unit	857CA02542-0220	200V
5	1	Front Cover	857CA02542-0184	
		Rear Cover	857CA02542-0165	

MINOLTA-QMS 4060 PARTS MANUAL

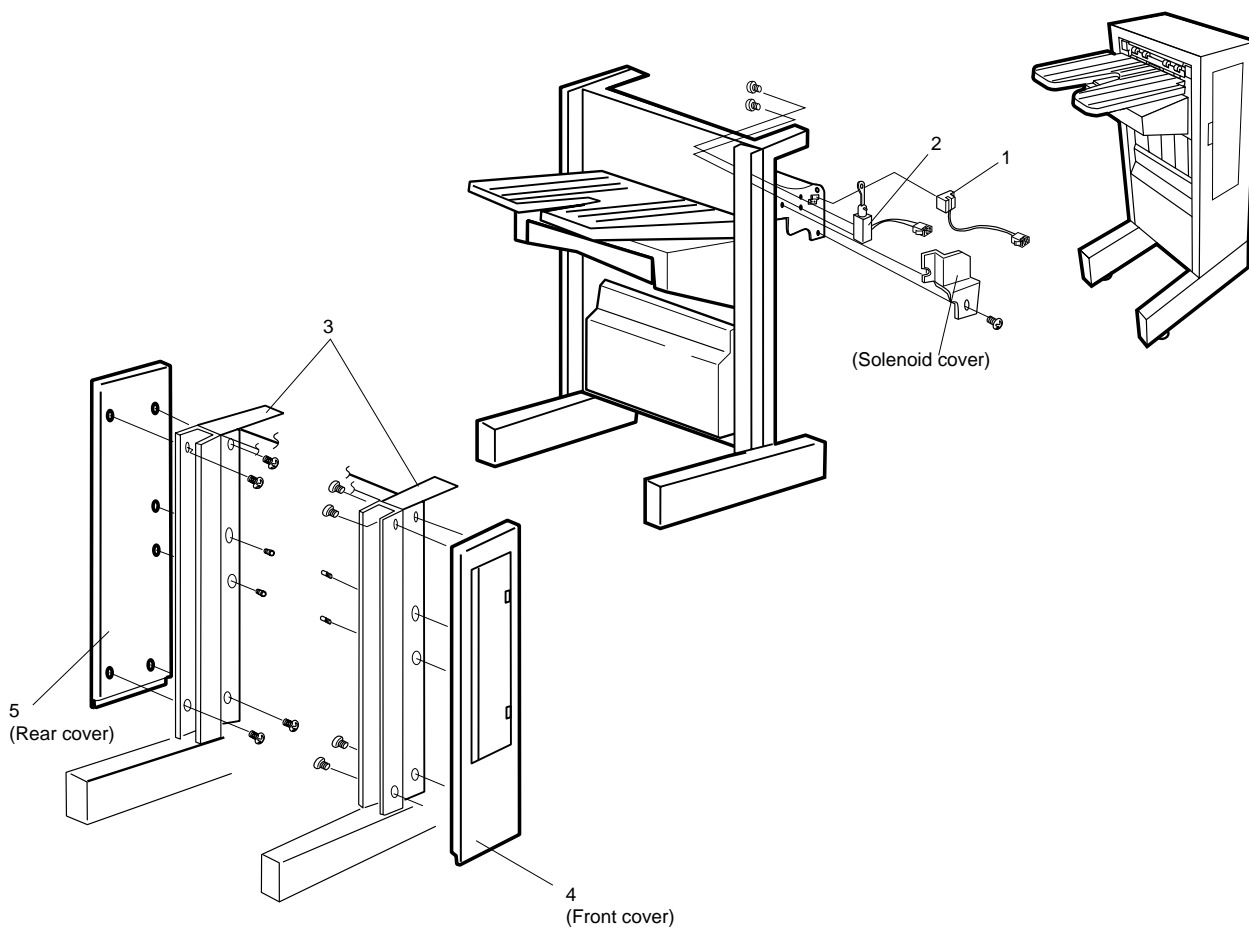

Figure 7-21. LCOS Controls and Covers Assemblies Parts Locational Diagram

MINOLTA-QMS 4060 PARTS MANUAL

7-5.4. LCOS Input-Paper Transport Assembly

Table 7-22. LCOS Input-Paper Transport Assembly Parts Listing

Index No.	Quantity	Description	Specification	Remarks
1	1	Jam Sensor	857CA02542-0152	SEN2
2	1	Power Supply (100V)	857CA02542-0160	100-120V
	1	Power Supply (200V)	857CA02542-0162	200-240V
3	1	PCB	857CA02542-0181	LCS Controller
4	1	Door Switch	857CA02542-0131	Front Door Switch SEN9
5	1	Tray Motor Assy	857CA02542-0194	
6	1	Locker Switch	857CA02542-0138	AC Power Switch
7	1	Jam Sensor	857CA02542-0152	SEN1
8	1	Sensor	857CA02542-0201	SEN5
9	1	Sensor	857CA02542-0201	SEN6
10	1	Bottom Switch	857CA02542-0158	Tray Full Switch (SEN7)
11	1	Right Side Cover	857CA02542-0187	
12	2	Tray Belt	857CA02542-0155	Tray up and down belt
13	2	Tray Pulley	857CA02542-0156	Lower pulley for tray belt
14	2	Tray Pulley	857CA02542-0166	Upper pulley for tray belt

MINOLTA-QMS 4060 PARTS MANUAL

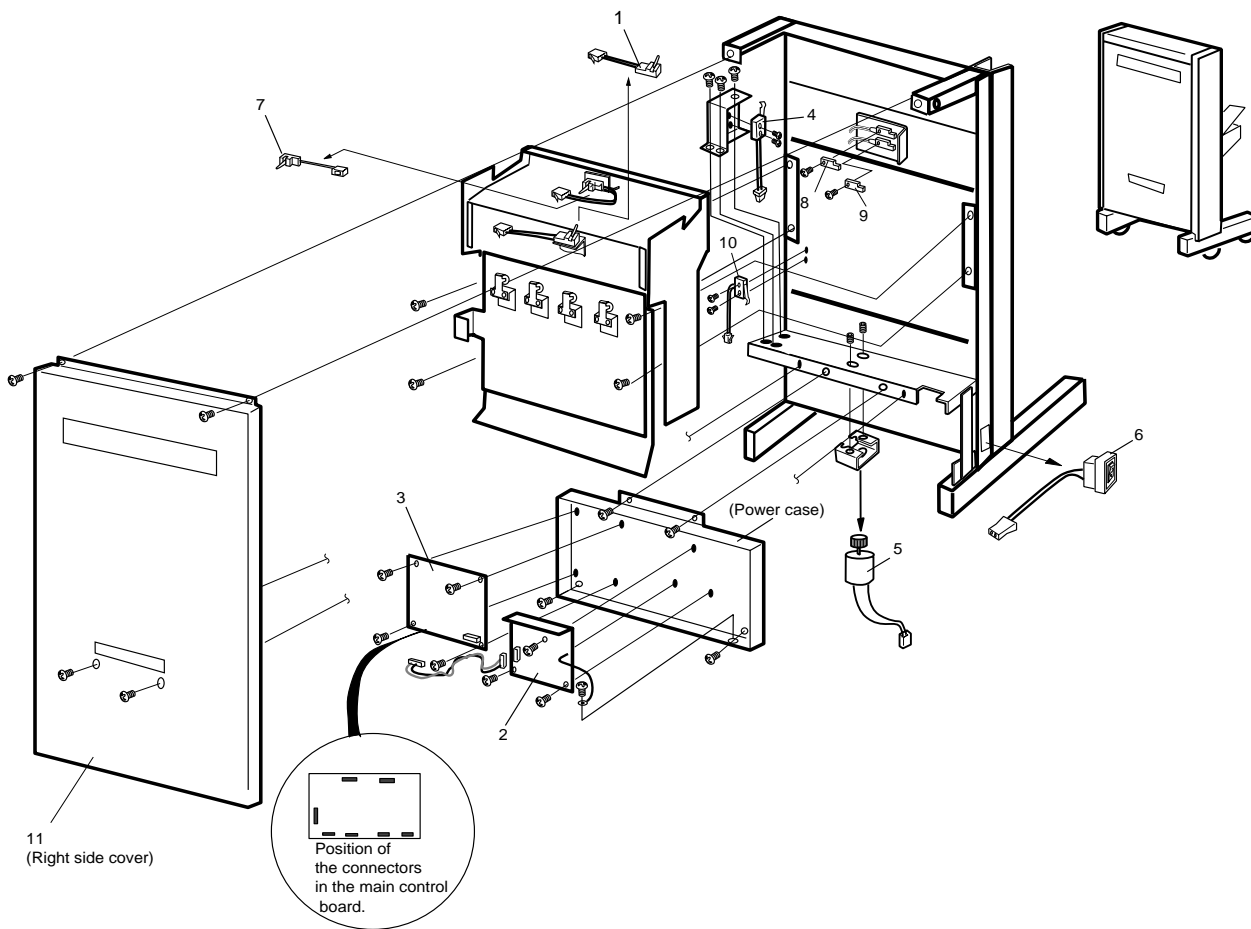

Figure 7-22. LCOS Input-Paper Transport Assembly Parts Locational Diagram

MINOLTA-QMS 4060 PARTS MANUAL

7-5.5. LCOS Output-Paper Transport Assembly

Table 7-23. LCOS Output-Paper Transport Assembly Parts Listing

Index No.	Quantity	Description	Specification	Remarks
1	4	Reverse Idler Assembly	857CA02542-0198	
2	4	Feed Idler Assembly	857CA02542-0197	
3	1	Feed Motor	857CA02542-0115	
4	1	Feed Motor Gear	857CA02542-0145	
5	1	Feed Gear	857CA02542-0107	
6	1	Guide Gear	857CA02542-0109	
7	1	Exit Pulley	857CA02542-0173	
8	1	Exit Belt	857CA02542-0151	
9	1	Exit Motor	857CA02542-0149	
10	1	Exit Motor Pulley	857CA02542-0146	
11	1	Feed Roller	857CA02542-0141	
12	4	Exit Idler Assembly	857CA02542-0196	
13	1	Reverse Pulley	857CA02542-0147	
14	1	Exit Belt	857CA02542-0204	
15	1	Exit Roller	857CA02542-0230	
16	1	Reverse Roller	857CA02542-0140	
17	1	Paper Feed Unit	857CA02542-0200	
18	1	Film Guide	857CA02542-0203	

MINOLTA-QMS 4060 PARTS MANUAL

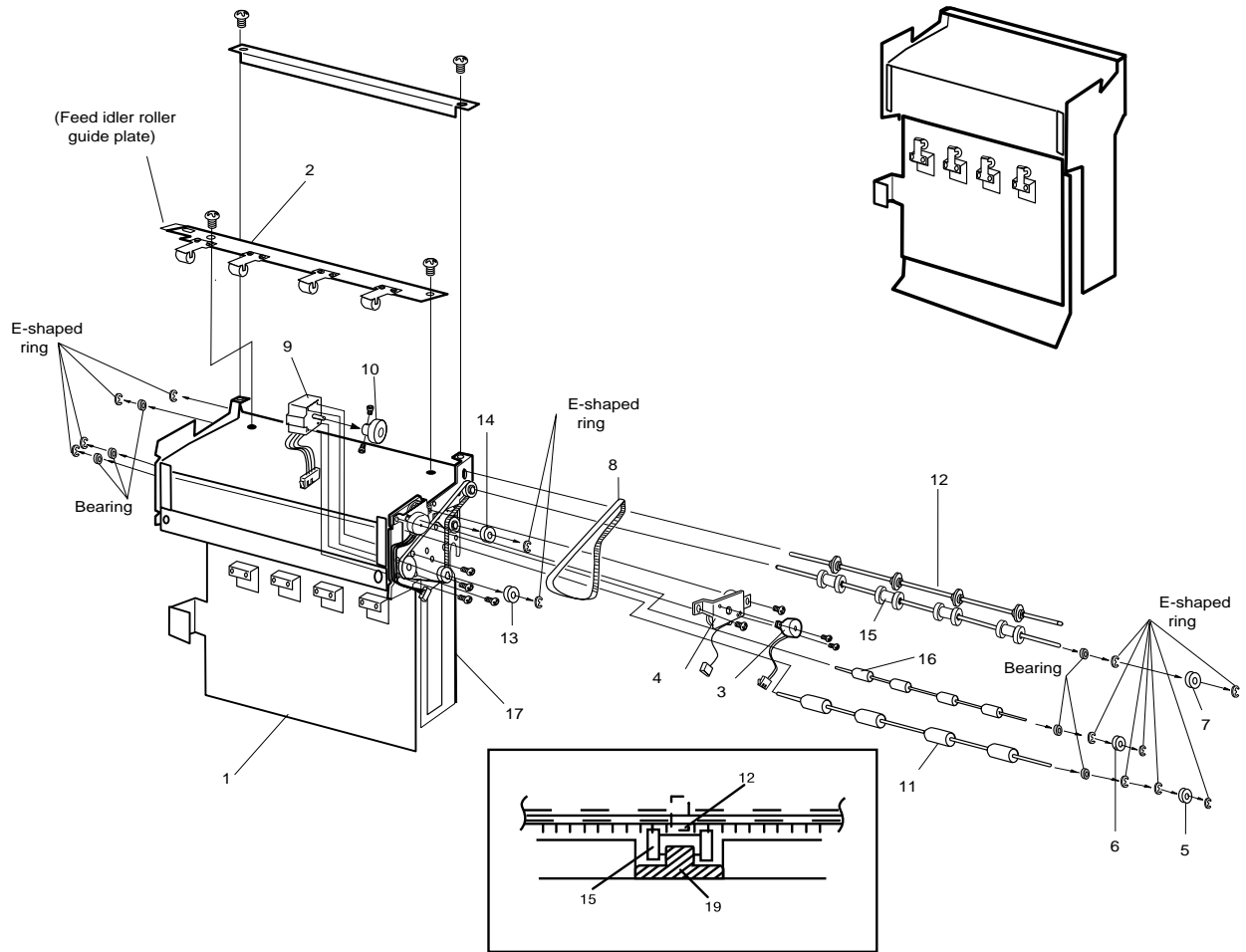

Figure 7-23. LCOS Output-Paper Transport Assembly Parts Locational Diagram

MINOLTA-QMS 4060 PARTS MANUAL

APPENDIX A REFERENCE PRINTER DIAGRAMS

Appendix A content is:

Section

A-1	Printer Wiring Diagram	A-3
-----	------------------------------	-----

1-1. Printer Wiring Diagram

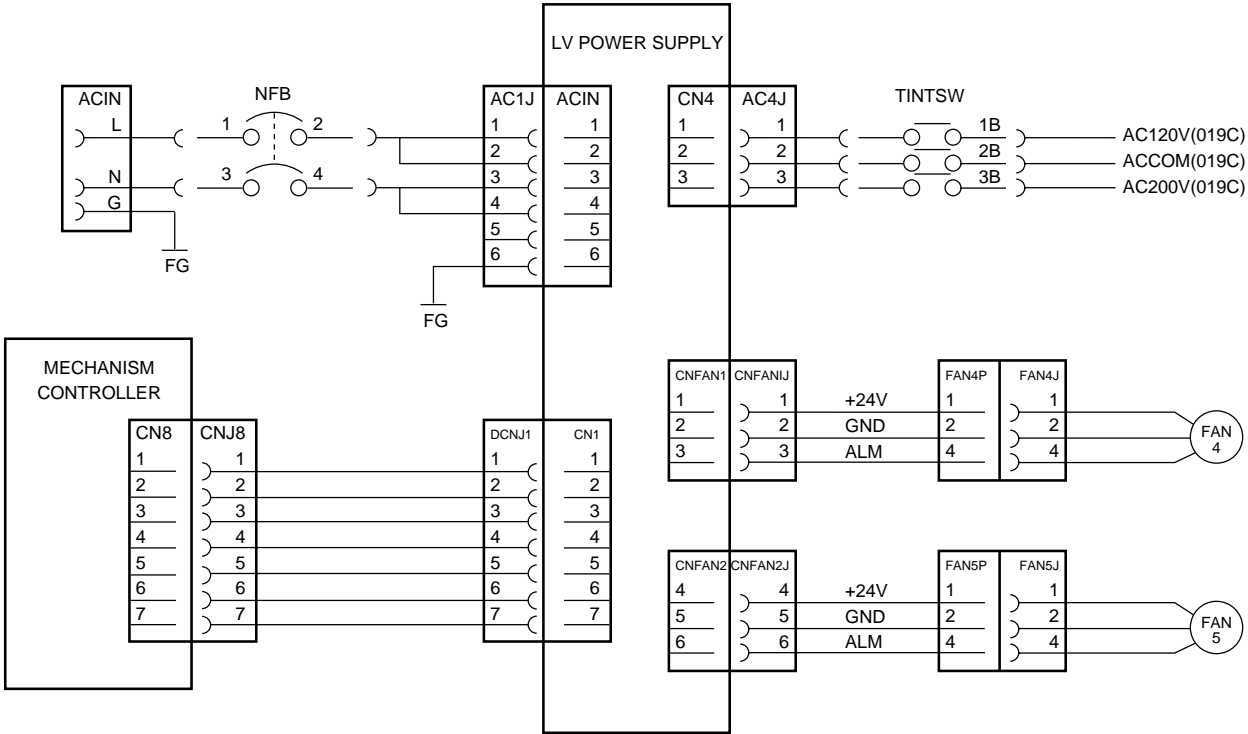

Figure A-1. Printer Wiring Diagram (Sh 1 of 20)

SERVICE MANUAL

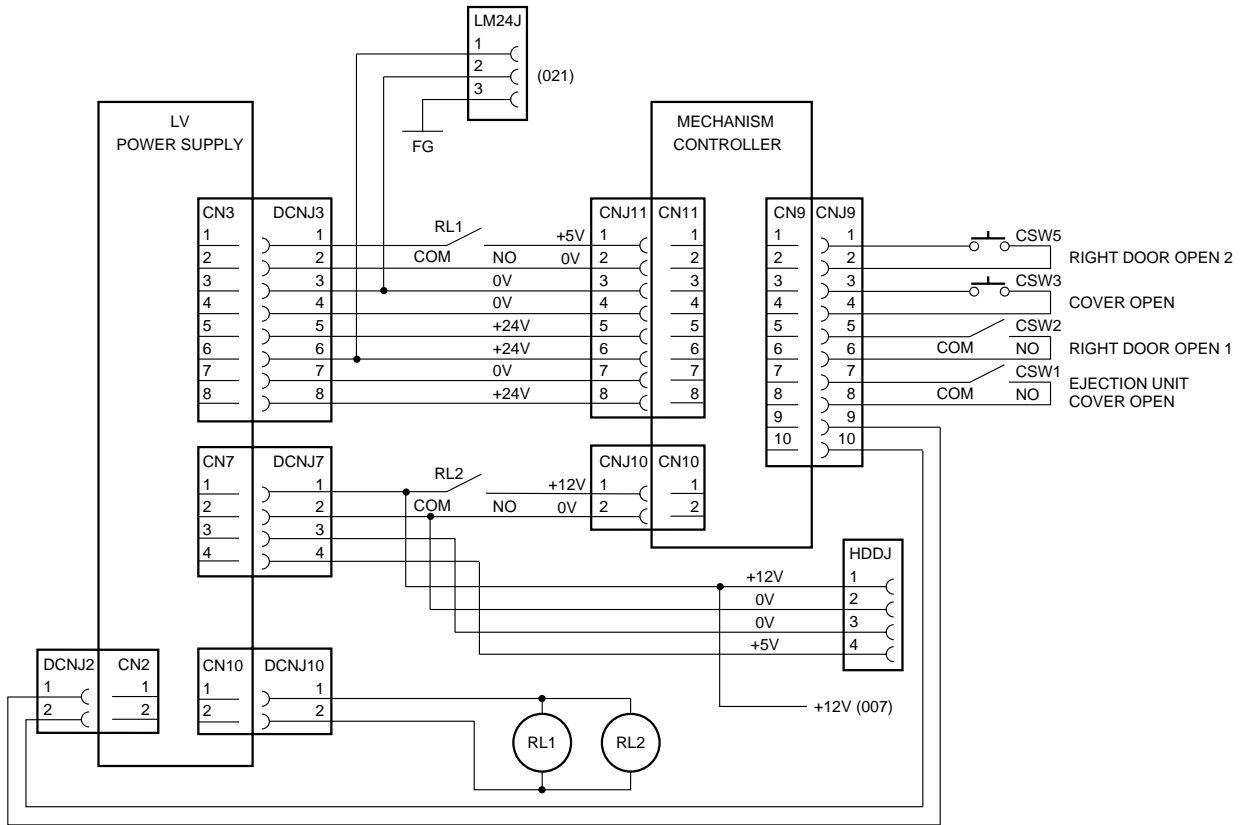

Figure 1-1. Printer Wiring Diagram (Sh 2 of 20)

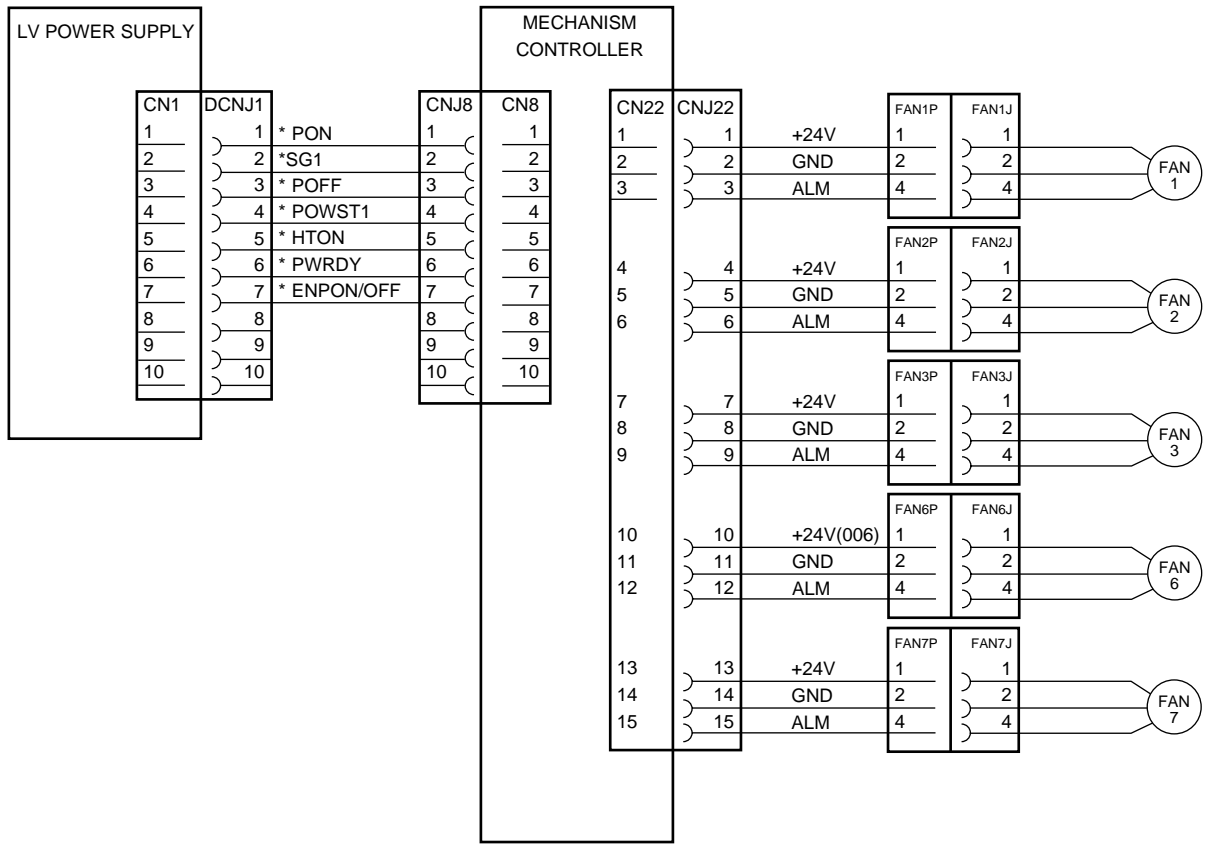

Figure 1-1. Printer Wiring Diagram (Sh 3 of 20)

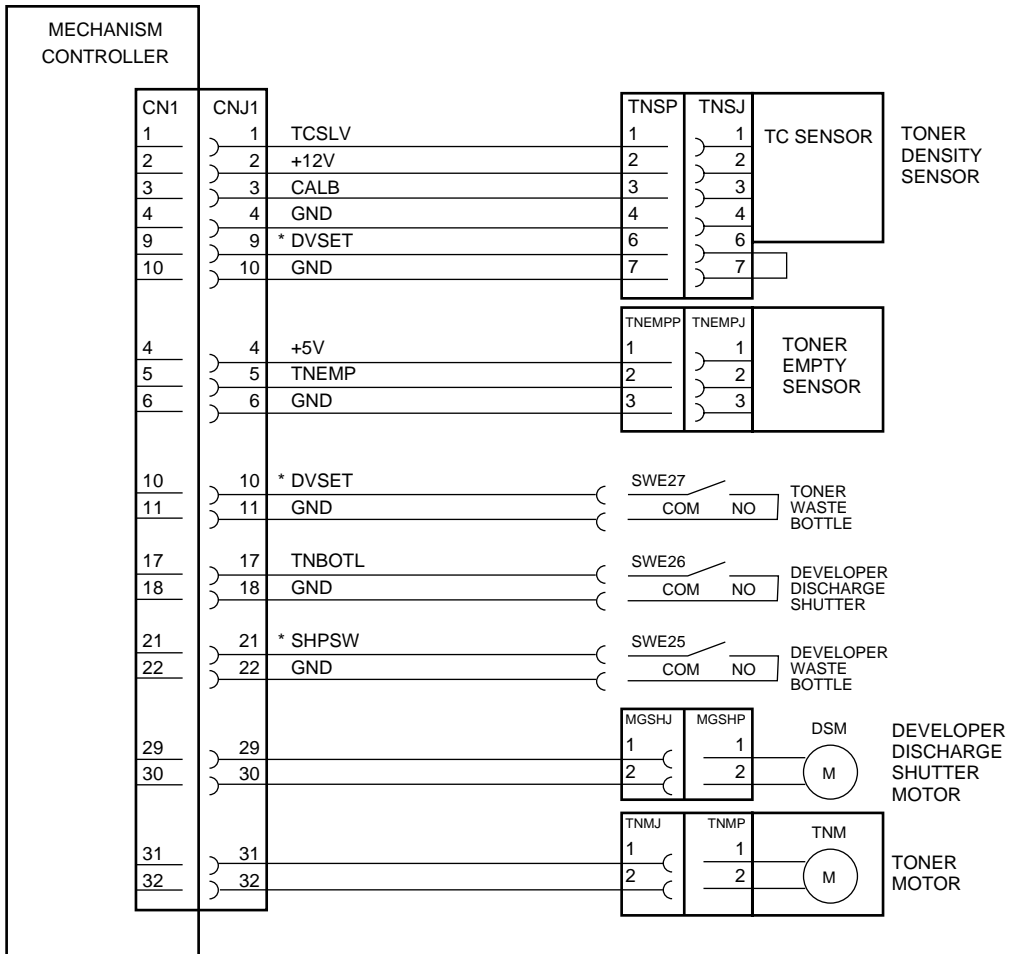

Figure 1-1. Printer Wiring Diagram (Sh 4 of 20)

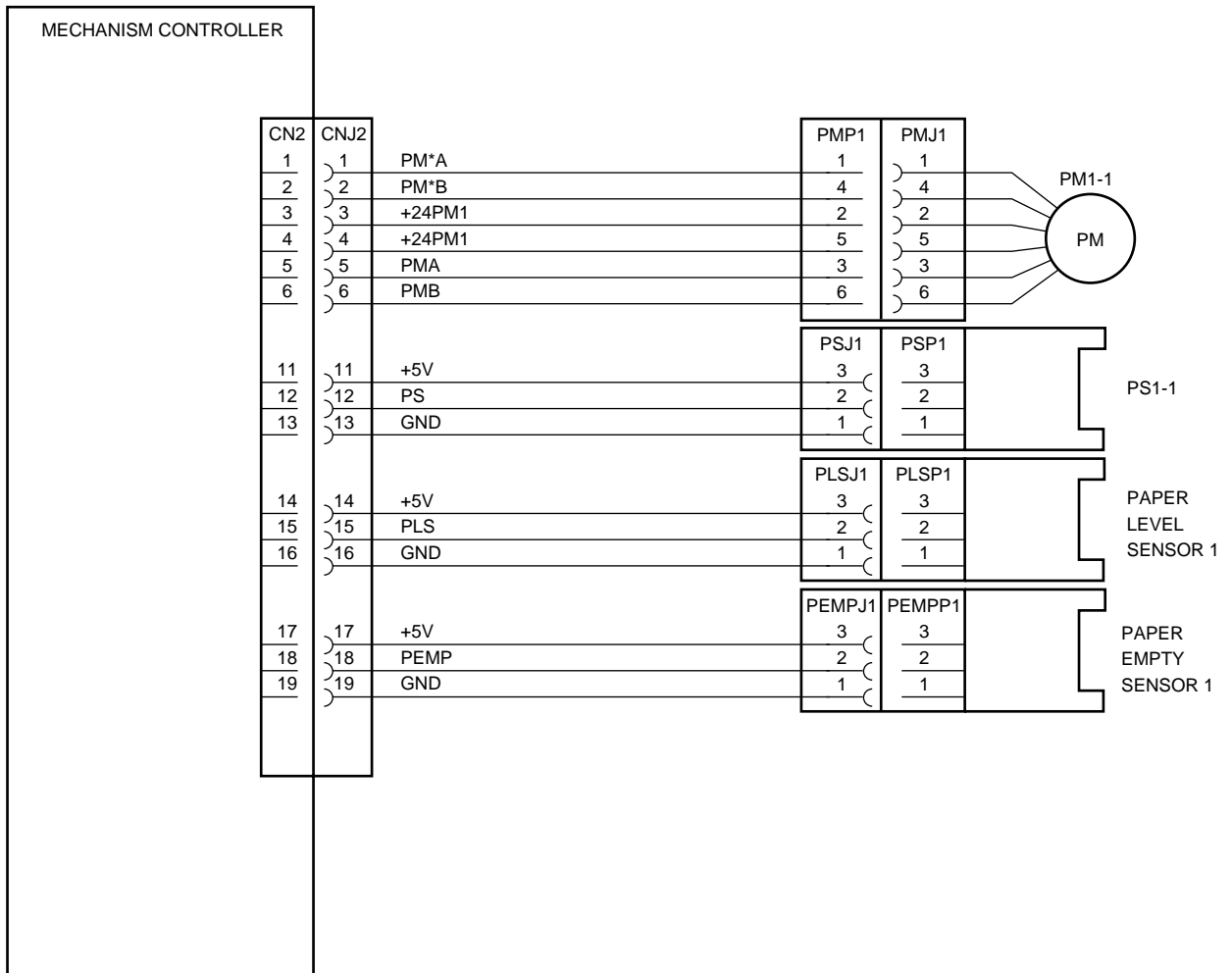

Figure 1-1. Printer Wiring Diagram (Sh 5 of 20)

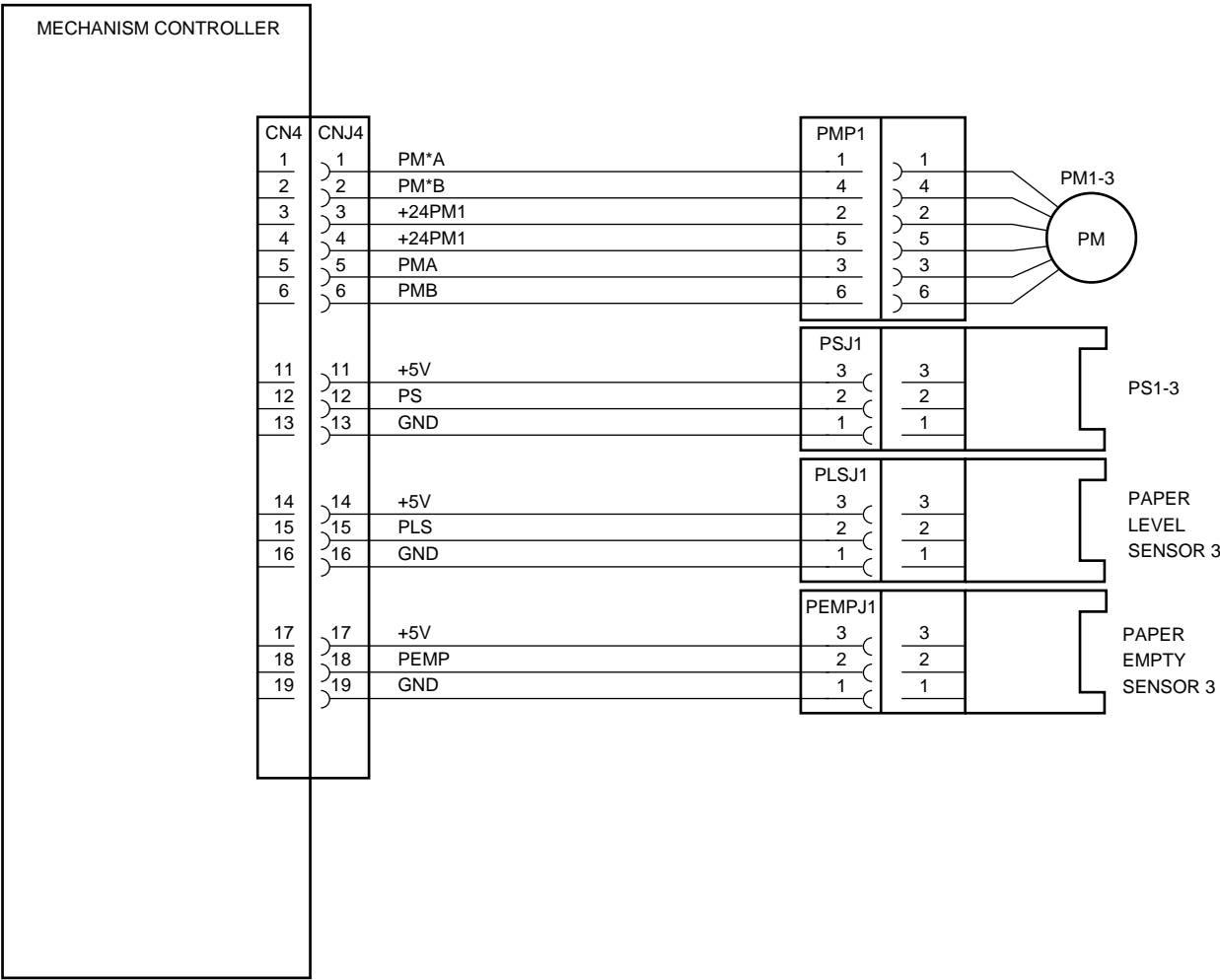

Figure 1-1. Printer Wiring Diagram (Sh 7 of 20)

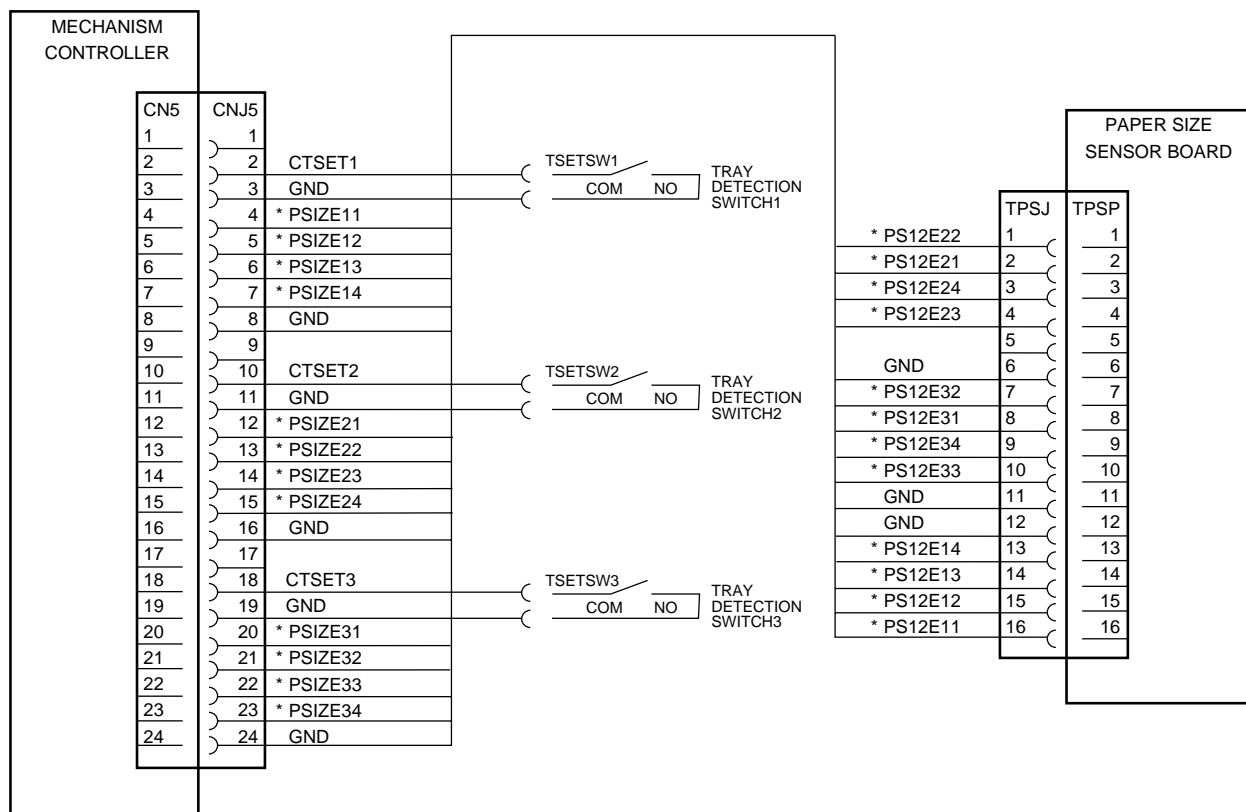

Figure 1-1. Printer Wiring Diagram (Sh 8 of 20)

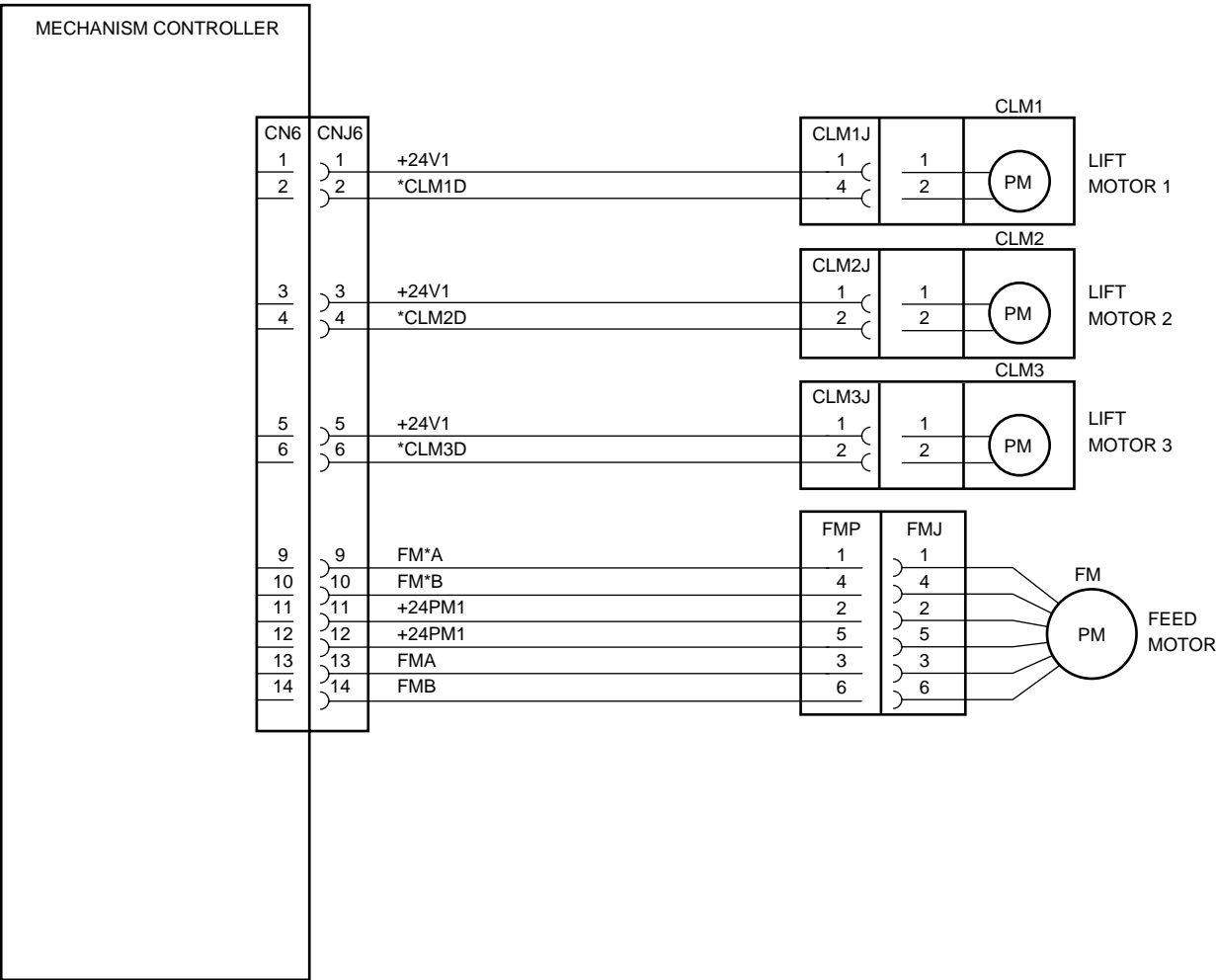

Figure 1-1. Printer Wiring Diagram (Sh 9 of 20)

SERVICE MANUAL

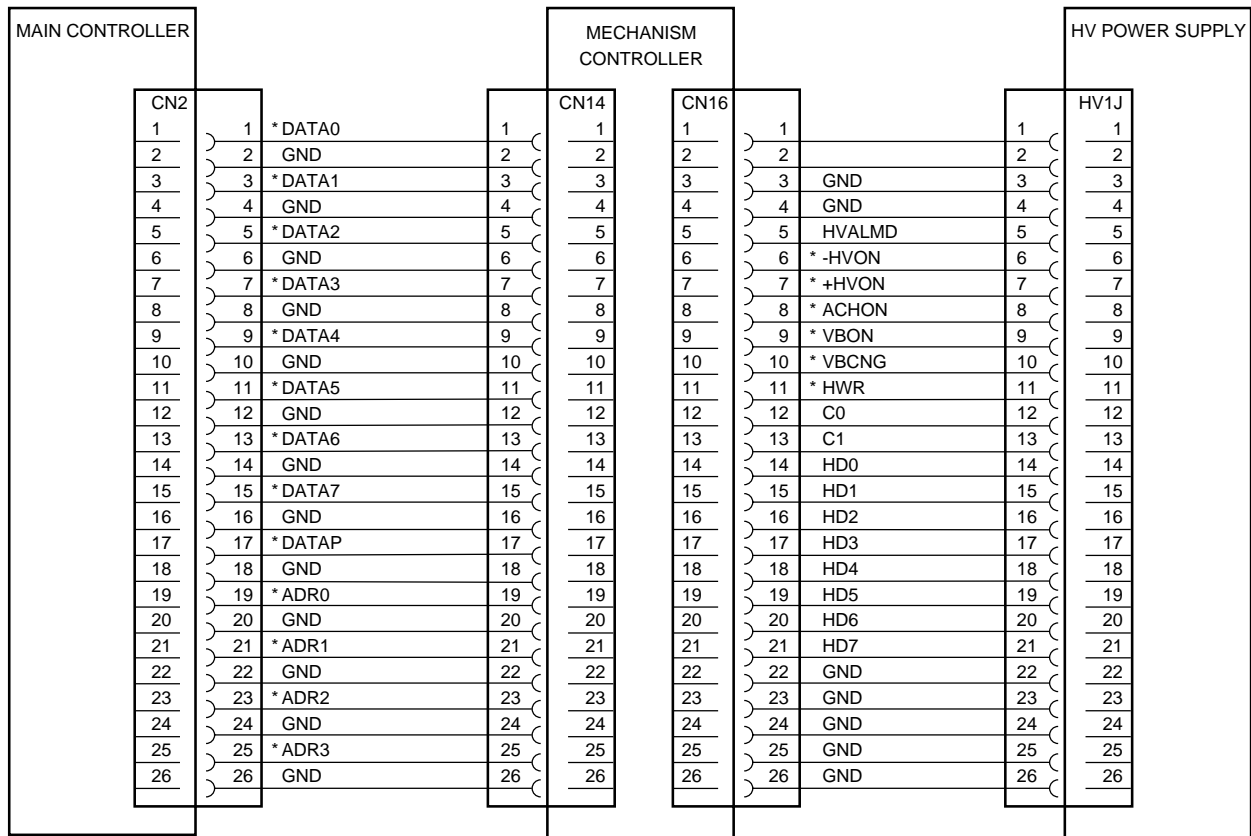

Figure 1-1. Printer Wiring Diagram (Sh 10 of 20)

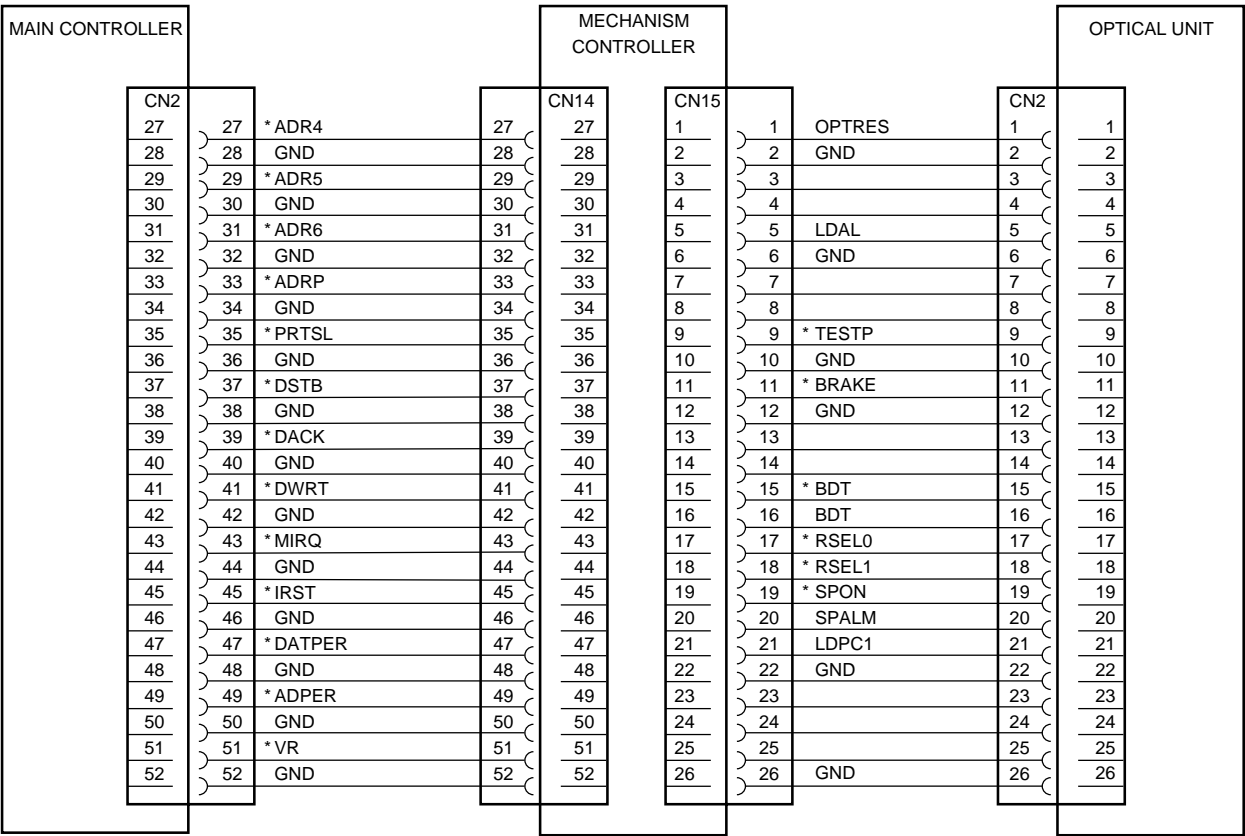

Figure 1-1. Printer Wiring Diagram (Sh 11 of 20)

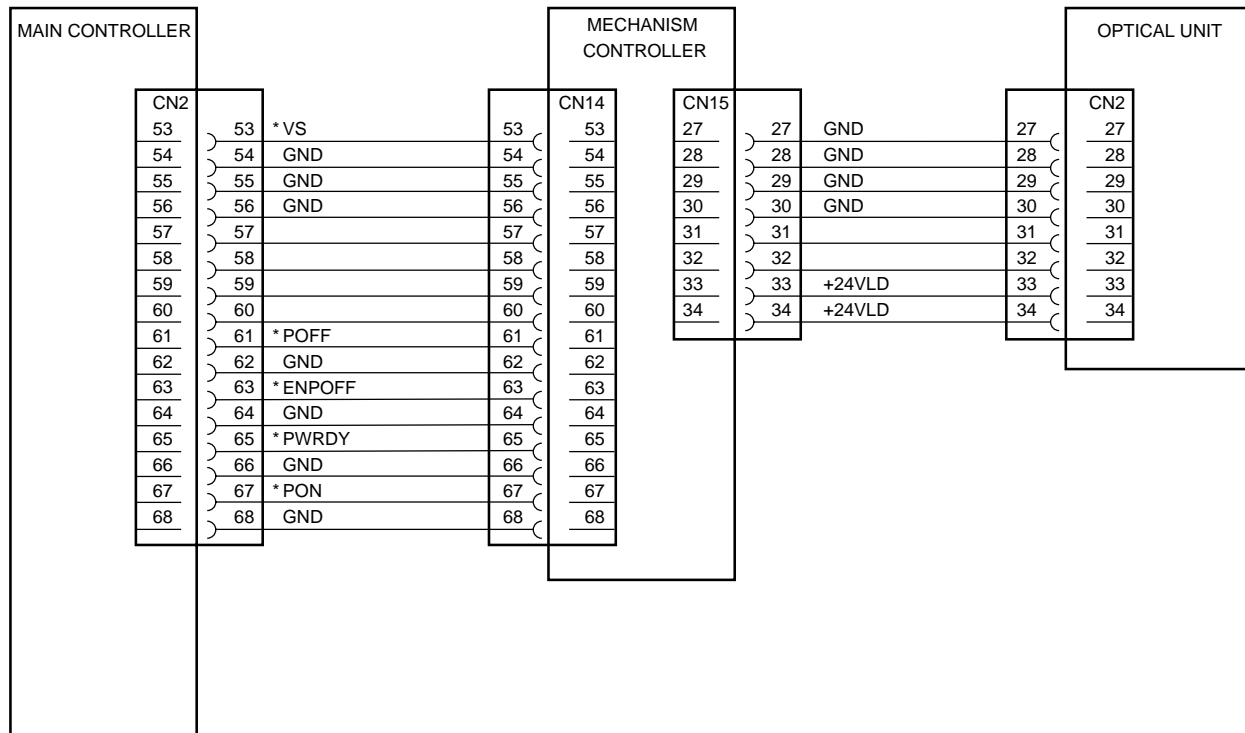

Figure 1-1. Printer Wiring Diagram (Sh 12 of 20)

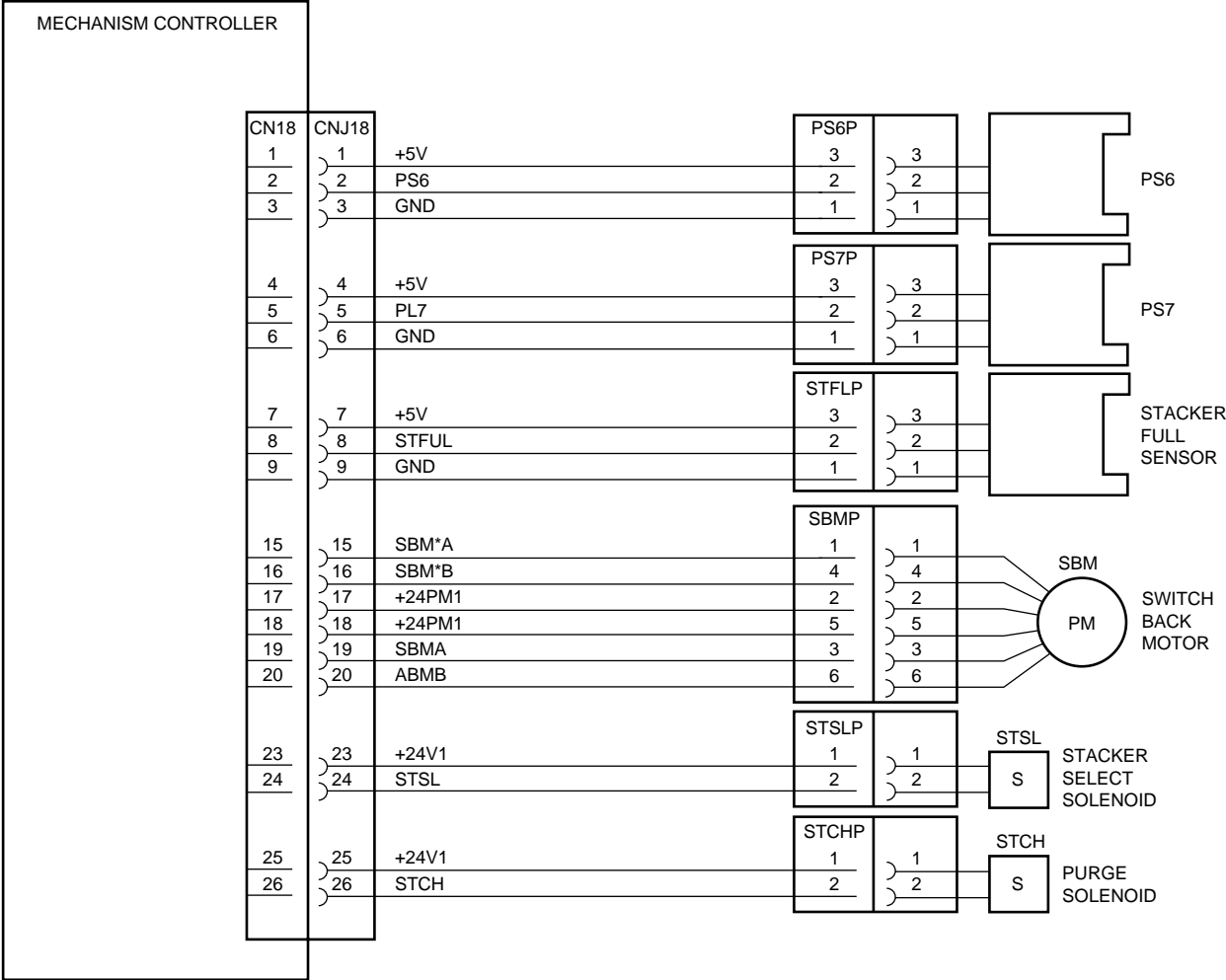

Figure 1-1. Printer Wiring Diagram (Sh 13 of 20)

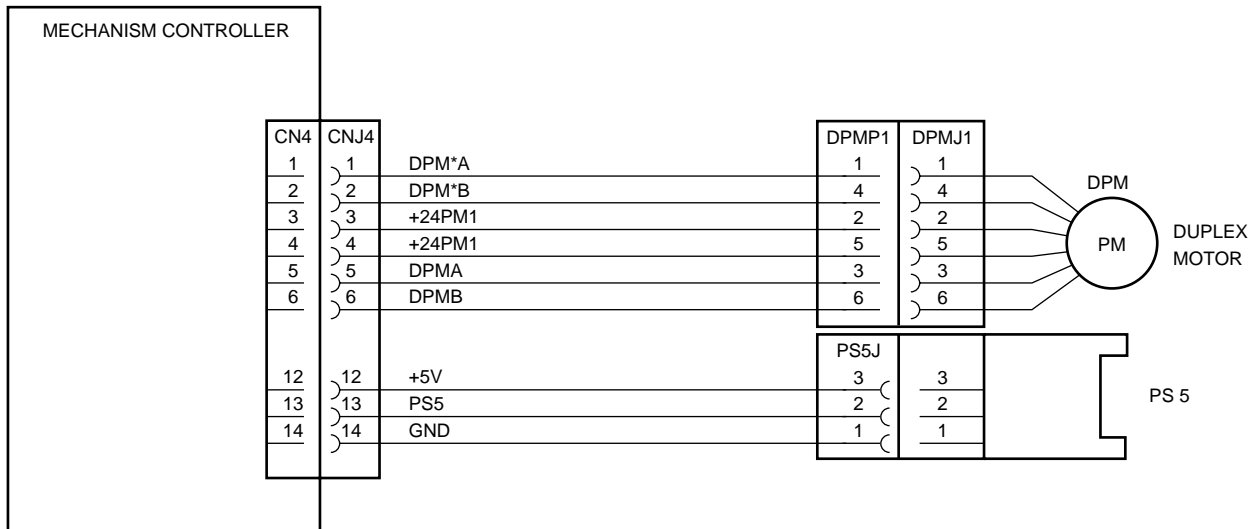

Figure 1-1. Printer Wiring Diagram (Sh 14 of 20)

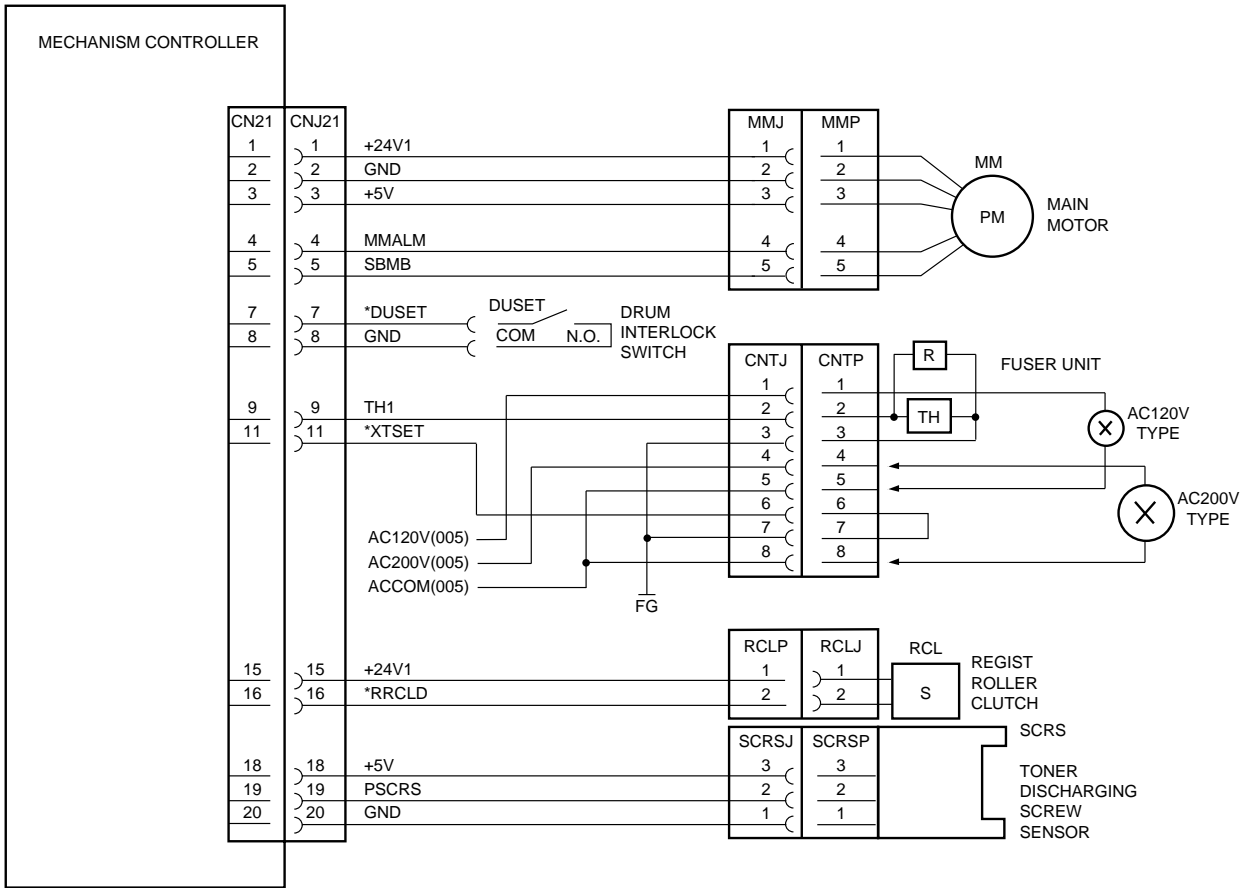

Figure 1-1. Printer Wiring Diagram (Sh 15 of 20)

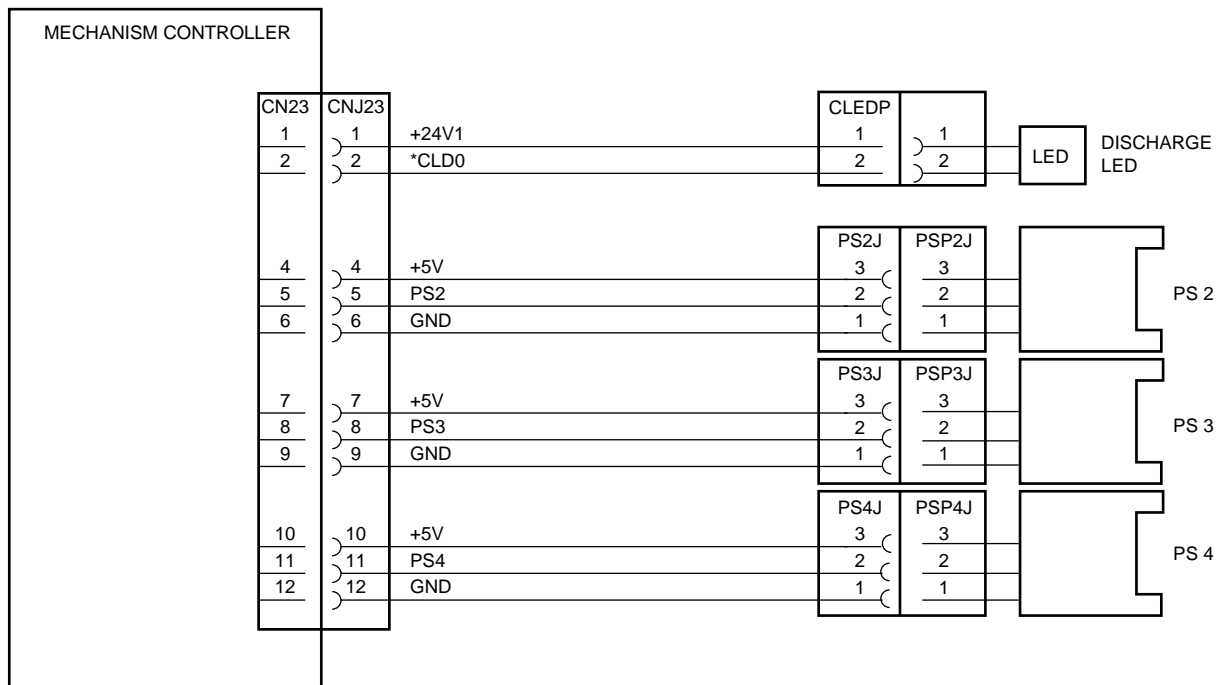

Figure 1-1. Printer Wiring Diagram (Sh 16 of 20)

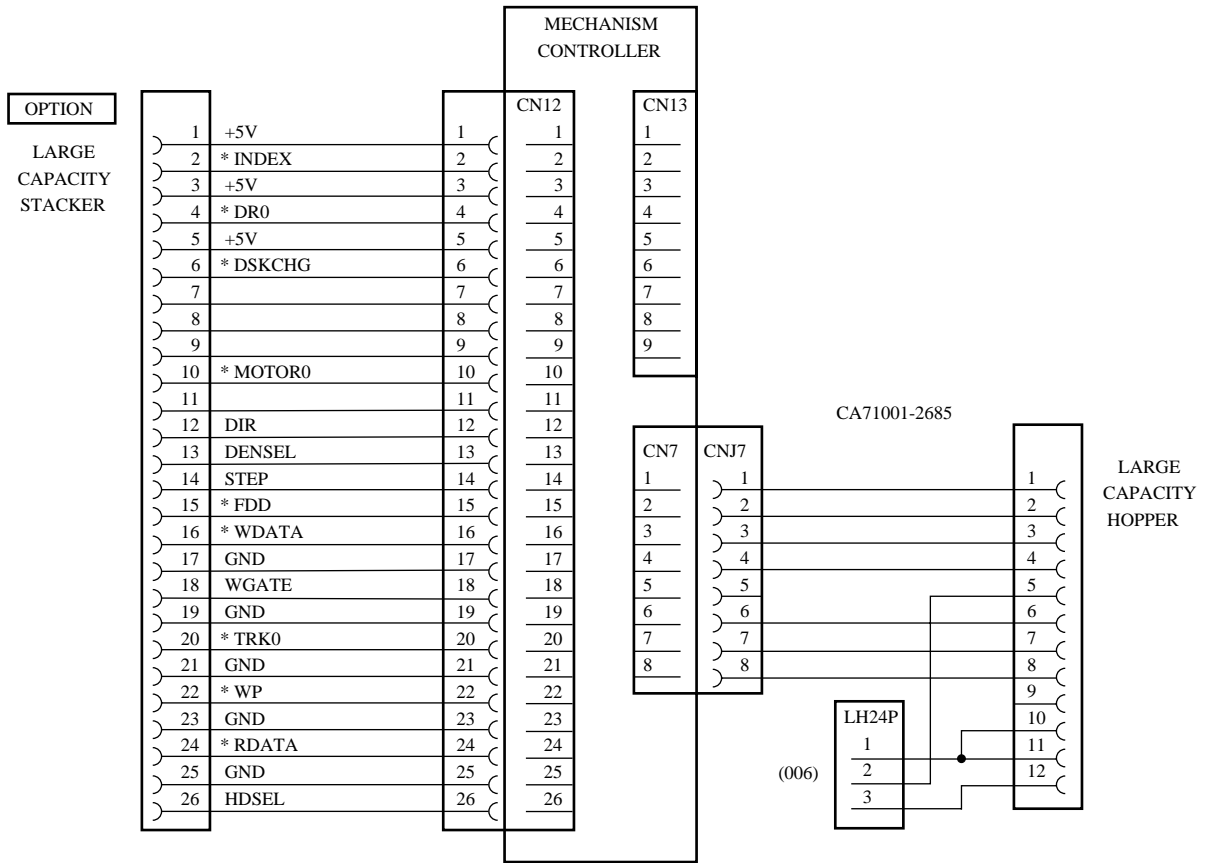

Figure 1-1. Printer Wiring Diagram (Sh 17 of 20)

SERVICE MANUAL

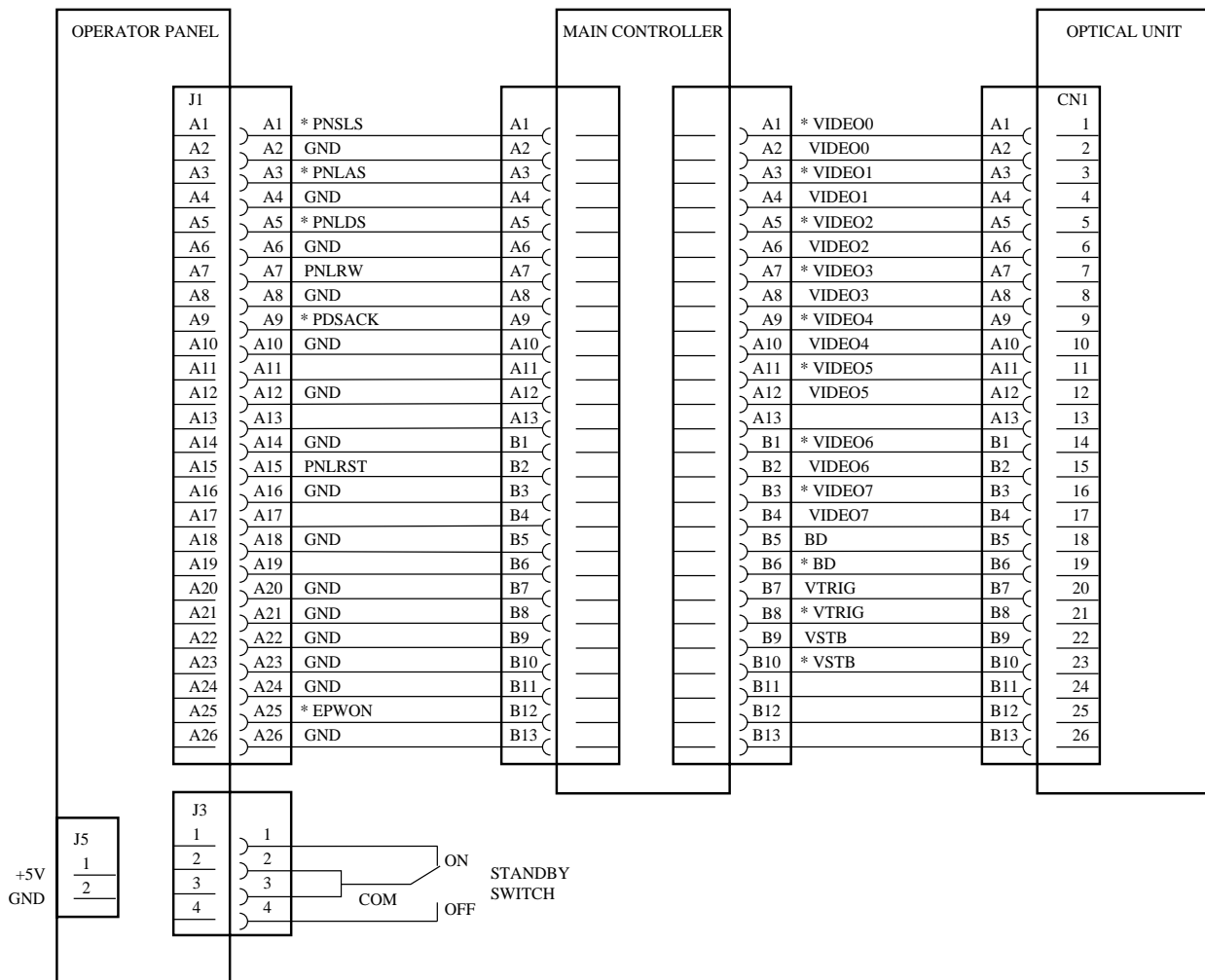

Figure 1-1. Printer Wiring Diagram (Sh 18 of 20)